

# **Smart Hydroponic System Based On Nutrient Film Technique**

Md. Ehsanul Hassan  
ID: 2014-1-60-001

Mohammad Maruf Islam  
ID: 2014-1-60-009

Fahmida Noor  
ID: 2014-1-60-010

A thesis submitted in partial fulfillment of the requirements for the  
degree of Bachelor of Science in Computer Science and Engineering



**Department of Computer Science and Engineering**

**East West University**

**Dhaka-1212, Bangladesh**

August, 2018

## Declaration

I, hereby, declare that the work presented in this thesis is the outcome of the investigation performed by me under the supervision of Dr. Ahmed Wasif Reza, Associate Professor and Chairperson, Department of Computer Science and engineering, East West University. I also declare that no part of this thesis has been or is being submitted elsewhere for the award of any degree or diploma.

Countersigned

Signature

.....

(Dr. Ahmed Wasif Reza)

.....

**(Md. Ehsanul Hassan)**

**( 2014-1-60-001)**

**Supervisor**

Signature

.....

**(Mohammad Maruf  
Islam)**

**(2014-1-60-009)**

Signature

.....

**(Fahmida Noor)**

**(2014-1-60-010)**

## Letter of Acceptance

This thesis report entitled “*Smart Hydroponic System Based on Nutrient Film Technique*” submitted by Md. Ehsanul Hassan (ID: 2014-1-60-001), Mohammad Maruf Islam (ID: 2014-1-60-009) and Fahmida Noor (ID: 2014-1-60-010) to the Department of Computer Science and Engineering, East West University is accepted by the department in partial fulfillment of requirements for the Award of the Degree of Bachelor of Science and Engineering on August, 2018.

Supervisor

.....

(Dr. Ahmed Wasif Reza)

Associate Professor and Chairperson,

Department of computer Science and Engineering, East West University

Chairperson

.....

(Dr. Ahmed Wasif Reza)

Associate Professor and Chairperson,

Department of computer Science and Engineering, East West University

---

## **Abstract**

Food is the primary source of energy and nutrients for human. Agriculture is the most important sector for providing food in our world. Our very existence depends on agriculture. From the very beginning of human civilization humans begin cultivation for their survival. With time and situation, the demand of food increased rapidly all over the world. But the agricultural productivity is decreasing due to degradation of land quality and decreasing of fertile lands and other resources. Traditional agricultural method cannot take the challenge we are going to face nearby future. To meet the increased demand of food all over the world, we need new method like hydroponic farming system which uses small space and fast growing technique. By implementing automation in hydroponic we can increase production quantity as well as production quality. This project proposes a smart hydroponic system by using some sensors to collect real-time data and actuators to execute appropriate action. Smart hydroponic system can collect real-time data of the system where farmers can remotely monitor these values. Farmers don't need additional knowledge to use this system. This system can directly impact on the agricultural production as well as on present farming method. To make the full use of our resources, this system helps farmer by providing data. Farmers can harvest more and make efficient decision with the help of this system.

---

## **Acknowledgments**

As it is true for everyone, we have also arrived at this point of achieving a goal in our life through various interactions with and help from other people. However, written words are often elusive and harbor diverse interpretations even in one's mother language. Therefore, we would not like to make efforts to find best words to express my thankfulness other than simply listing those people who have contributed to this thesis itself in an essential way. This work was carried out in the Department of Computer Science and Engineering at East West University, Bangladesh.

First of all, we would like to express my deepest gratitude to the almighty for His blessings on us. Next, our special thanks go to our supervisor, Dr. Ahmed Wasif Reza, who gave us this opportunity, initiated us into the field of IoT, and without whom this work would not have been possible. His encouragements, visionaries and thoughtful comments and suggestions, unforgettable support at every stage of our BS.c study were simply appreciating and essential. His ability to muddle us enough to finally answer our own question correctly is something valuable what we have learned and we would try to emulate, if ever I/We get the opportunity.

We would like to thank "Dr. Mohammad Salah Uddin" for his overall support and his valuable suggestion during making of electrical conductivity sensor. Last but not the least, we would like to thank our parents for their unending support, encouragement and prayers.

## Acknowledgments

---

There are numerous other people too who have shown me their constant support and friendship in various ways, directly or indirectly related to our academic life. We will remember them in our heart and hope to find a more appropriate place to acknowledge them in the future.

Md. Ehsanul Hassan

August, 2018

Mohammad Maruf Islam

August, 2018

Fahmida Noor

August, 2018

---

## Table of Contents

<b>Declaration of Authorship</b>	<b>i</b>
<b>Letter of Acceptance</b>	<b>ii</b>
<b>Abstract</b>	<b>iii</b>
<b>Acknowledgment</b>	<b>iv</b>
<b>Table of Contents</b>	<b>vi</b>
<b>List of Figures</b>	<b>viii</b>
<b>List of Tables</b>	<b>x</b>
<b>List of Algorithms</b>	<b>xii</b>
<b>Chapter 1 Introduction</b>	<b>1</b>
1.1: Overview and motivation.....	1
1.2: Problem Statements.....	3
1.3: Thesis Objective .....	4
1.4: Thesis Organization.....	4
<b>Chapter 2 Literature Review</b>	<b>5</b>
2.1 Introduction.....	5
2.2 What is Hydroponic Farming.....	5
2.3 Nutrient Film Technique.....	6
2.4: Existing Works on Hydroponic.....	7
2.5: Comparative Studies.....	8

<b>Chapter 3</b>	<b>Research Methodology</b>	<b>9</b>
3.1:	Materials .....	9
3.2:	Flowchart .....	16
3.3:	Algorithms.....	18
3.4:	Experimental setup.....	19
<b>Chapter 4</b>	<b>Results and discussion</b>	<b>23</b>
4.1:	Introduction .....	23
4.2:	Results and analysis .....	23
4.2.1:	Analysis Using Graph.....	23
4.2.2:	Analysis Using Classification Algorithms.....	26
4.2.2.1:	Performance Metrics for Classification.....	26
4.2.2.2:	Dataset for Classification.....	27
4.2.2.3:	J48 Classification Algorithm.....	27
4.2.2.4:	K-Nearest Neighbor Classification Algorithm.....	30
4.2.2.5:	Comparison of Classification Result.....	34
<b>Chapter 5:</b>	<b>Conclusion</b>	<b>36</b>
5.1:	Conclusion.....	36
5.2:	Future Work.....	37
<b>Bibliography</b>		<b>38</b>
<b>Appendix A</b>	<b>List of Acronyms</b>	<b>40</b>
<b>Appendix B</b>	<b>List of Notations</b>	<b>43</b>



---

## List of Figures

1. Figure 1. Nutrient Film Technique .....	06
2. Figure 2. Arduino Mega.....	09
3. Figure 3. 12Volt Water Pump.....	10
4. Figure 4. 5Volt Relay .....	10
5. Figure 5. Temperature Sensor DS18B20.....	11
6. Figure 6. pH Sensor.....	12
7. Figure 7. EC Sensor.....	12
8. Figure 8. DHT22 Sensor (Temperature & Humidity Sensor) .....	13
9. Figure 9. Wi-Fi Module (ESP8266-01) .....	14
10. Figure 10. Hydroponic Solution A and B.....	15
11. Figure 11. Flow Chart .....	17
12. Figure 12. Circuit Diagram.....	19
13. Figure 13. Picture of our Smart Hydroponic System.....	20
14. Figure 14. Motor Connection with Arduino.....	20
15. Figure 15. pH Sensor Connection with Arduino.....	21
16. Figure 16. EC Sensor Connection With Arduino.....	21
17. Figure 17. DHT22 Connection with Arduino.....	22

18. Figure 18. DS18B20 Connection with Arduino.....	22
19. Figure 19. Temperature of Nutrient Solution.....	23
20. Figure 20. pH Values of Nutrient Solution.....	24
21. Figure 21. Temperature of Environment.....	24
22. Figure 22. Electrical Conductivity of Nutrient Solution.....	25
23. Figure 23. Humidity Values of Environment.....	25
24. Figure 24. J48 vs KNN with 5-fold Cross Validation Result Comparison.....	34
25. Figure 25. J48 vs KNN with 70 percent split dataset Result Comparison .....	35

## List of Tables

2.1	Comparative Study Table.....	08
3.1	Amount of Chemical Elements used in 1000 ml Nutrient Solution.....	09
4.1	Classification result for class: “ph up” with 5 fold cross validation (1).....	27
4.2	Classification result for class: “ph up” with 5 fold cross validation (2).....	27
4.3	Classification result for class: “ph down” with 5 fold cross validation (1).....	28
4.4	Classification result for class: “ph down” with 5 fold cross validation (2).....	28
4.5	Classification result for class: “solution up” with 5 fold cross validation (1).....	28
4.6	Classification result for class: “solution up” with 5 fold cross validation (2).....	28
4.7	Classification result for class: “ph up” with 70 percent split dataset (1).....	29
4.8	Classification result for class: “ph up” with 70 percent split dataset (2).....	29
4.9	Classification result for class: “ph down” with 70 percent split dataset (1).....	29
4.10	Classification result for class: “ph down” with 70 percent split dataset (2).....	29
4.11	Classification result for class: “solution up” with 70 percent split dataset (1).....	30
4.12	Classification result for class: “solution up” with 70 percent split dataset (2).....	30
4.13	Classification result for class: “ph up” with 5 fold cross validation, K=3 (1).....	31
4.14	Classification result for class: “ph up” with 5 fold cross validation, K=3 (2).....	31
4.15	Classification result for class: “ph down” with 5 fold cross validation, K=3 (1).....	31
4.16	Classification result for class: “ph down” with 5 fold cross validation, K=3 (1).....	31

4.17	Classification result for class: “solution up” with 5 fold cross validation, K=3 (1).....	32
4.18	Classification result for class: “solution up” with 5 fold cross validation, K=3 (2).....	32
4.19	Classification result for class: “ph up” with 5 fold cross validation, K=3 (1).....	32
4.20	Classification result for class: “ph up” with 5 fold cross validation, K=3 (2).....	32
4.21	Classification result for class: “ph down” with 70 percent split dataset, K=3 (1).....	33
4.22	Classification result for class: “ph down” with 70 percent split dataset, K=3 (2).....	33
4.23	Classification result for class: “solution up” with 70 percent split dataset, K=3 (1).....	33
4.24	Classification result for class: “solution up” with 70 percent split dataset, K=3 (2).....	33

# List of Algorithms

3.3 Smart Hydroponic System.....	18
----------------------------------	----

# Chapter 1

---

## Introduction

With increasing population and urbanization all over the world, Food and Agriculture Organization of the United Nations has predicted that the demand of food production will be increased by 70% by 2050 [1]. On the other hand, excessive use of pesticides and fertilizers have decreased the productivity of fertile lands. A study showed that almost 33 percent of the world's fertile high productive land has lost its high productivity rate [2]. Continuous use of land for cultivation has degraded the quality of soil. These statistics shows us that our very existence is at stake as agriculture is our main source of food. The traditional farming system cannot take the challenge we are going to face in near future. To address these issues and increase the quantity of agricultural production we need to use more smart technology for farming such as smart hydroponic system.

### 1.1 OVERVIEW AND MOTIVATION

In traditional farming, a farmer generally ploughs a land and sow seeds and with his previous experience he puts fertilizers and grow crops. In this traditional method the productivity depends on many factors such as water, soil, fertilizer, weather and etc. Here, apart from other factors land plays a very important role in agricultural production. To meet the global demand, food production must be doubled by 2050 for increased population [3]. But the degradation of fertile land and increasing population has made it very difficult for the current generation. A study of 1990 shows that almost 11 percent of the world's land area is used at that time and additionally 12 percent has some potential for production [4].

Moreover, agricultural productivity is very susceptible to climate change. According to World Bank (2008), agribusiness contributes to approximately 30 percent of the **GDP** developing countries [5].

By using smart hydroponic farming technology various environmental factors can be controlled for higher agricultural production. Moreover, the main feature of the method is that it is a soil free cultivation method. Plants are nature's ultimate source of food. In order to achieve the fullest production quantity and quality of a plant it must be provided with everything accordingly. Every plant needs appropriate temperature, water, air and nutrients to reach its full genetic potential. Plants collect its necessary nutrients from soil to live.

In hydroponics plants grow without soil. Plants collect all their nutrients from a given nutrient solution. By controlling environment temperature, water and nutrient solution plants can be more productive. Hydroponic growing (as opposed to soil growing) allows you to control the nutrient levels for your plants directly. Because of the higher control over nutrients, hydroponically grown

---

plants generally have a much higher yield than similar plants grown in soil. In this project, we will show our implementation of smart hydroponic system where the nutrient solution, temperature and other environmental factors will be controlled automatically. Smart hydroponic farming can solve the problem food productive as we can control every factor that contributes in plant growing and cultivation process. There are various hydroponic methods. Some of them are:

**Deep water culture:** In this method, roots are suspended in nutrient solution continuously. Aquarium air pump oxygenates the nutrient solution which prevents plant roots from drowning.

**Nutrient film technique:** This is the most popular technique among the growers. Small vegetables can be grown by using this technique. A continuous flow of nutrient solution runs over the plant's root. In this method, plants get more oxygen from air since only a part of root comes to the contact of nutrient solution.

**Aeroponics:** There are two method to provide solution to the plant roots. The first one is to use spray the roots another is to use pond fogger.

**Wicking:** Wicking is a very cost efficient hydroponic method. Plants are surrounded by the growing medium and nutrient solution is wicked to the roots.

**Ebb and Flow:** It is also known as flood and drain system. In this method the growing medium is flooded by nutrient solution and then the solution is slowly drained back to the reservoir.

**Drip system:** It is a slow nutrient feeding system. In this system, nutrient solution is slowly provided to the roots and also a slow draining system is used.

In this project, we have used nutrient film technique method for our implemented system. This technique is more popular because of plant's fast growing rate. Farmers don't have care about the timing of nutrient solution as it is a continuous process. This technique is vastly used for vegetables. But any time of plants can be grown using this technique. This method requires less maintenance.

---

## 1.2 PROBLEM STATEMENT

To meet the increasing demand of food of the world population smart and latest agricultural system needs to be implemented. A simple but smart technology is needed which would be easy to implement and can return better results with the agricultural productivity. A complex system could be difficult to implement for farmers. The use of automated and smart agriculture system can reduce the complexity and task of farmers which can result in better productivity. Moreover, a smart farming system can achieve better production quality. Farming should be simple and more profitable so that more people become encouraged in farming. Since, land quality is degrading day by day and arable lands are decreasing with the development of urban areas hydroponic can be the best solution for farming. We must focus on an established technology which give us assurance of better productivity.

So, in order to develop a smart hydroponic system for better use of resources and implementation following factors need to be considered.

- ❖ The system should be cost efficient.
- ❖ System should meet the necessary requirements of farming.
- ❖ Necessary data collection of various environmental factors should be in real time
- ❖ The system should be developed for farmers who usually don't have knowledge about software and other technical aspects.

In this thesis paper, we will design and implement a smart hydroponic farming system by using temperature sensor, humidity sensor, ph sensor, electrical conductivity sensor, 12V water pump and wifi module. We will also use ThingSpeak cloud platform to store collected data from various sensors for further analysis. In the end, we will also analyze our collected data through various classification algorithm to validate results of the device.

Our system's functionality depends on the following factors:

- ❖ Real time data collection from sensors
- ❖ Accuracy of sensor's data
- ❖ Data analysis over collected data



---

### **1.3 THESIS OBJECTIVES**

In this paper, we have proposed a smart hydroponic farming system which collects temperature, pH and electrical conductivity of nutrient solution, temperature of environment and takes proper decision and implement them through actuators by monitoring these data. Our proposed system can lessen the complexity of maintenance of a hydroponic farming and can play a key role to develop the quantity and quality of agricultural productivity.

In the process of developing our proposed system we have set the following objectives:

- ❖ To design smart hydroponic farming system by using low cost microcontroller, sensors and actuators
- ❖ To implement the system and analyze the resulted data

In this thesis paper, our aim is to make a prototype of a smart hydroponic farming system which can be easily implemented by anyone or anywhere so that it can provide the most efficient result. The implementation of this system can change the view of traditional agricultural productivity. The use of smart hydroponic method in farming can greatly impact the food production in our country. In this paper, the concept of smart hydroponic farming is briefly discussed. This paper gives an implementation of the proposed system. Wi-Fi sensor is used to collect real time data plant nutrient and other environmental factors. At last the paper discusses the result analysis of collected data through various sensors using decision tree classification algorithm.

### **1.4 THESIS ORGANIZATION**

We have organized our rest of the paper as follows. In chapter 2, we have discussed about hydroponic technique in order to introduce hydroponic method and its possibility in future agricultural productivity. In this section, we have also discussed about existing related works. In chapter 3, we have proposed our methodology. We discussed materials, sensors and devices that we used to develop the smart hydroponic farming system. We also discussed flow chart and algorithm we used in our proposed system. In this section, we have also discussed about experimental setup. In chapter 3, we have discussed about data collection, result analysis and discussion. Finally chapter 5 gives a conclusion of this paper.

# **Chapter 2**

---

## **Literature Review**

### **2.1 INTRODUCTION**

This chapter provides a discussion on the hydroponic farming technology, brief description on various hydroponic techniques. In addition to these, this chapter also discussed about existing works on hydroponic farming.

### **2.2 What is Hydroponic farming?**

Hydroponic is generally known as “the cultivation of plants in water” [16]. Hydroponic is the science of feeding nutrients to plants to reach for its full genetic potential and provide greater agricultural productivity. In this method, plants grow faster and need less space for farming. By using this method in a well-controlled system growers can easily cultivate plants. The basic idea is that, provide nutrient solution to plants and control environmental other factors such as temperature, humidity etc. in a efficient way so that plants can grow spontaneously and can reach its full growth at a faster pace. Various techniques of hydroponic is used by various farmers and researchers. Anyone can modify these techniques according to their need and start growing plants.

## 2.3 Nutrient Film Technique

Nutrient Film Technique which is also known as **N.F.T.** was first pioneered by Allen Cooper at the Glasshouse Crops Research Institute in Little Hampton, England [6]. This technique is very popular because of its fairly simple design. Small vegetables like lettuce etc. are cultivated using this technique.

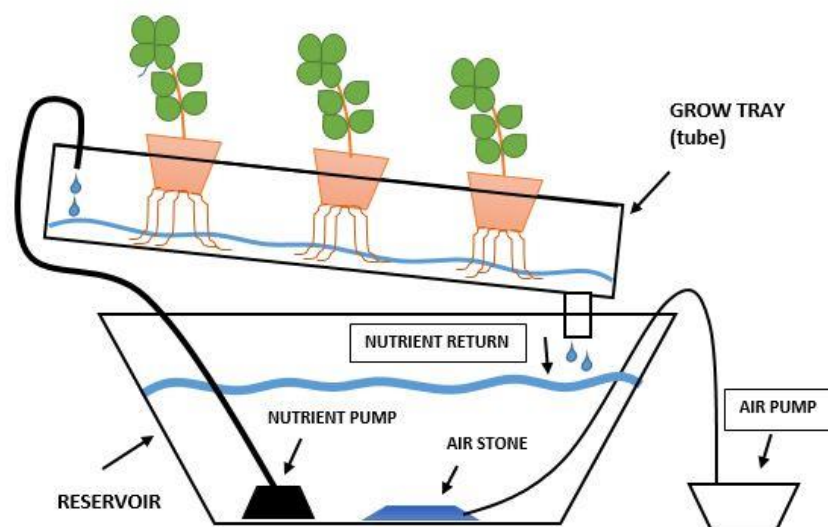

Figure 1: Nutrient Film Technique

To build a N.F.T. system following factors need to be considered:

- ❖ Need a container for nutrient reservoir
- ❖ Need a water pump
- ❖ Need pipe for nutrient distribution
- ❖ Need to keep seedlings in a small plastic pot or baskets
- ❖ Need to ensure the returning of nutrient solution to the reservoir

---

## 2.4 Existing Works on Hydroponic

Many researchers and scholars have done works using different methods of hydroponic farming for better food quality and quantity. In this section of the paper, we discussed about some existing works already done by various researchers.

In [7], authors devised a system using Arduino Uno, Wifi shield, Relay, Temperature sensor, Electrical conductivity sensor, Ph sensor, Solenoid sensor and Ultrasonic sensor. They developed an android mobile application for monitoring the system and operating it. The system sends notification through mobile application if any values of sensors changed beyond threshold value. Through the application necessary commands to actuators can be sent.

In [8], authors have developed a system with Arduino Uno microcontroller, wifi module ESP-8266 and also used Raspberry Pi 2 Model B microcomputers as the webserver with the concept of internet of things. They used solar powered battery to provide energy to the system. This is an automated system and farmers have to select appropriate settings for different plants.

In [9], authors presented the design of an embedded system to control nutrients for hydroponics. They also implemented forward chaining method for decision making in the decision. They used potential of hydrogen sensor, electrical conductivity sensor, temperature sensor, cooling fan and water pump.

In [10], authors developed a prototype using Arduino Uno R3, GP2Y0A21 proximity sensor as a water level indicator and TDS sensor as a detector of electrical conductivity of nutrient solution. The system can start watering and add nutrition automatically when the nutrition solution concentration goes below 800ppm.

## 2.5 Comparative Studies

In this section of the paper, we analyzed some previous works done by other researchers and showed our results in a comparative study table.

Table 2.1: Comparative Study Table

SR No.	Author's Name	Proposed system	Device/material used	Advantages of the study	Disadvantages
1	Somchoke Ruengittinun, Sitthidech Phongsamsuan, Phasawut Sureeratana korn	Used mobile application to send notification to users and monitor the system	Arduino Uno, Wifi shield, Relay, temperature sensor, Electrical conductivity sensor, Ph sensor, Solenoid sensor and Ultrasonic sensor	Remote monitoring and controlling system.	Controlling system is not automated
2	Padma Nyoman Crisnapati, Nyoman Kusuma Wardana, Komang Agus Ady Aryanto, Agus Hermawan	They monitor and control the NFT hydroponic system.	Arduino Uno microcontroller, wifi module ESP-8266 and also used Raspberry Pi 2 Model B	Automated system with web server	Complex system
3	Yakub Eka Nugraha, Budhi Irawan, Randy Erfa Saputra	Automation system with forward chaining method	EC sensor, Ph sensor, temperature sensor	Implementation of forward chaining method	Slower rate of learning, Depends on given condition

# Chapter 3

---

## Research Methodology

### 3.1 MATERIALS

In our device we use total nine type of sensor and hardware they are Arduino mega,5v relay,12v DC water pump, water temperature sensor (DS18B20), humidity and temperature sensor(DHT22),PH sensor (SKU:SENO161),EC sensor , 12 volt battery ,6 liter plastic centenary ,plastic pipe

#### a) **Arduino ATmega256**

The Arduino Mega 2560 is a microcontroller board based on the ATmega2560 . It has 54 digital input/output pins (of which 14 can be used as PWM outputs), 16 analog inputs, 4 UARTs (hardware serial ports), a 16 MHz crystal oscillator, a USB connection, a power jack, an ICSP header, and a reset button. It contains everything needed to support the microcontroller; simply connect it to a computer with a USB cable or power it with a AC-to-DC adapter or battery to get started. The Mega is compatible with most shields designed for the ArduinoDuemilanove or Diecimila.[11]

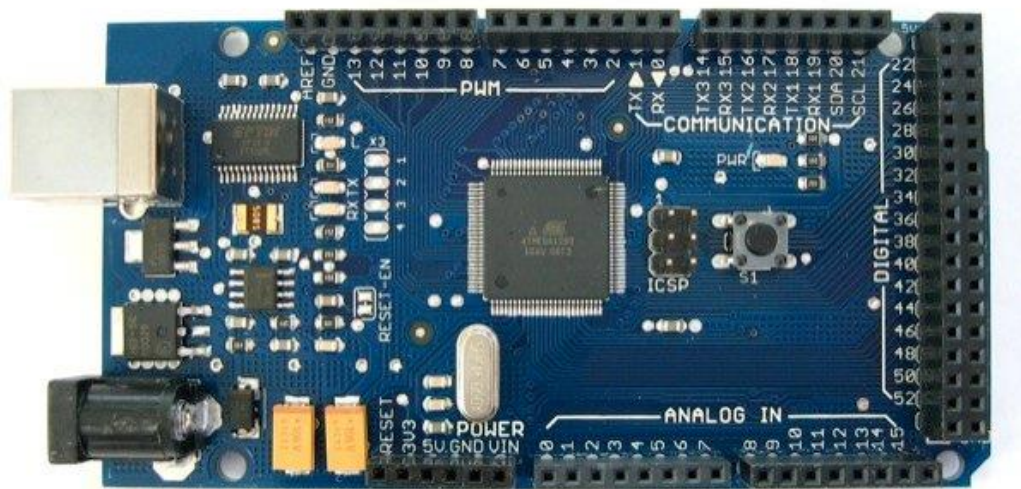

Figure2:Arduino Mega



#### d) **DS18B20 Temperature Sensor**

The DS18B20 Digital Thermometer provides 9 to 12-bit (configurable) temperature readings which indicate the temperature of the device. Information is sent to/from the DS18B20 over a 1-Wire interface, so that only one wire (and ground) needs to be connected from a central microprocessor to a DS18B20. Power for reading, writing, and performing temperature conversions can be derived from the data line itself with no need for an external power source. Because each DS18B20 contains a unique silicon serial number, multiple DS18B20s can exist on the same 1-Wire bus. This allows for placing temperature sensors in many different places. Applications where this feature is useful include HVAC environmental controls, sensing temperatures inside buildings, equipment or machinery, and process monitoring and control.



Figure5:Temperature Sensor DS18B20

#### e) **pH sensor:**

pH measurements are predominantly conducted with pH-sensitive glass electrodes, which have, in general, proven satisfactory in measurements of pH. However, the behavior of pH-sensitive glass electrodes often falls short of what precision is required. Standard pH Glass Electrode, Endress& Hauser Orbisint CPS 11 together with an electronic unit Liquisys M CPM 223. The electrode is fitted with a PTFE diaphragm, is filled with gel and contains an integrated Pt100 temperature sensor for temperature compensation. It is relatively stable against pressure fluctuations within the system. [12]



**Calibration of pH sensor:**

For calibration, the standard procedure is applied, using two buffer solutions with  $\text{pH}=7\pm 0.02$  and  $\text{pH}=9\pm 0.02$  (Titrisol from Merck) which can be traced to SRM (NIST) and PTB (Germany). Temperature corrections of the buffer solution as given by the manufacturer have to be applied.



Figure6: pH Sensor

**f) EC sensor :**

EC sensor measure the conductivity of a solution used in hydroponic gardening to measure the electrical conductivity of nutrient solutions to allow adjustment of nutrients, salts, and other elements for healthier plant growth. Taking an EC reading allows an indoor gardener to use a mathematical formula to determine the amount of total dissolved solids (TDS) within the solution as parts per million (PPM). EC meters and pH meters are both used to help growers perfect their nutrient solutions. Some manufacturers make combo meters, which combine the functionality of both types of meters into one kit. For this device we build our own EC sensor device [17].

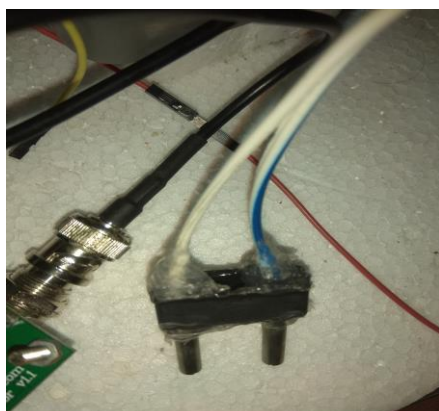

Figure7:EC sensor

### g) **DHT22 Temperature & Humidity Sensor:**

The DHT22 is a basic, low-cost digital temperature and humidity sensor. It uses a capacitive humidity sensor and a thermistor to measure the surrounding air, and spits out a digital signal on the data pin (no analog input pins needed). It's fairly simple to use, but requires careful timing to grab data. The only real downside of this sensor is you can only get new data from it once every 2 seconds.



Figure 8: DHT22 Sensor (Temperature & Humidity Sensor)

### h) **ESP8266-01 Wi-Fi Module:**

The ESP8266 Wi-Fi Module is a self-contained SOC with integrated TCP/IP protocol stack that can give any microcontroller access to your Wi-Fi network. The ESP8266 is capable of either hosting an application or offloading all Wi-Fi networking functions from another application processor. Each ESP8266 module comes pre-programmed with an AT command set firmware, meaning, you can simply hook this up to your Arduino device and get about as much Wi-Fi-ability as a Wi-Fi Shield offers (and that's just out of the box)! The ESP8266 module is an extremely cost effective board with a huge, and ever growing, community. This module has a powerful enough on-board processing and storage capability that allows it to be integrated with the sensors and other application specific devices through its GPIOs with minimal development up-front and minimal loading during runtime. Its high degree of on-chip integration allows for minimal external circuitry, including the front-end module, is designed to occupy minimal PCB area. The ESP8266 supports APSD for VoIP applications and Bluetooth co-existence interfaces, it contains a self-calibrated RF allowing it to work under all operating conditions, and requires no external RF parts. There is an almost limitless fountain of information available for the ESP8266,

all of which has been provided by amazing community support. In the *Documents* section below you will find many resources to aid you in using the ESP8266, even instructions on how to transforming this module into an IoT (Internet of Things) solution!

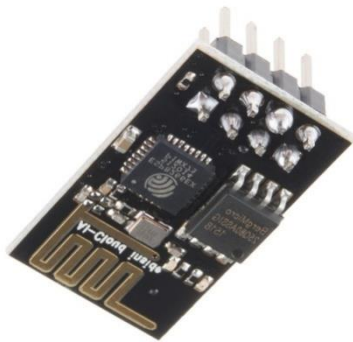

Figure9: Wi-Fi Module (ESP8266-01)

**i) Hydroponic solution :**

Hydroponics is a subset of hydroculture, the method of growing plants without soil, using mineral nutrient solutions in a water solvent. Terrestrial plants may be grown with only their roots exposed to the mineral solution, or the roots may be supported by an inert medium, such as perlite or gravel. The nutrients in hydroponics can come from an array of different sources; these can include but are not limited to byproduct from fish waste, duck manure, or *commercial fertilizers*.

There are two type of nutrient solution

1. Organic hydroponic solution
2. Inorganic hydroponic solution.

In our project we use inorganic hydroponic solution which contain two solution.Solution A and solution B. Solution A contain nitrates,iron,calcium and solution B contain phosphates,sulfates.We used below formula described in the below table for making nutrition solution [18].

Table 3.1: Amount of Chemical elements used in 1000 ml nutrient solution

Chemical Elements	Formula	Amount ( in gram)
Potassium Hydrogen Phosphate	$K_2HPO_4$	270
Potassium Nitrate	$KNO_3$	580
Calcium Nitrate	$Ca(NO_3)_2 \cdot 4H_2O$	1000
Magnesium Sulfate	$MgSO_4 \cdot 7H_2O$	510
EDTA Iron	$C_{10}H_{12}FeN_2O_8$	80
Manganese(II) sulfate	$MnSO_4 \cdot 4H_2O$	6.10
Boric Acid	$H_3BO_3$	1.80
Copper(II) sulfate	$CuSO_4 \cdot 5H_2O$	0.40
Ammonium Molybdate	$(NH_4)_6Mo_7O_{24} \cdot 4H_2O$	0.38
Zinc Sulfate	$ZnSO_4 \cdot 7H_2O$	0.44



Figure 10: Hydroponic solution A and B

### **3.2 FLOW CHART**

The flow chart given below describes the functionality of the system clearly. In the flow chart (Figure: 11), at first the system takes temperature of nutrient solution, environment and humidity. After taking these input, if environment temperature is greater than 30 degree Celsius then the cooling fan will turn on otherwise the cooling fan will turn off. After that the system waits for 10 seconds and after just 10 seconds, the system reads pH value from pH sensor. If the pH value is less than 5 then pH up motor turns on and if pH value is greater than 7 the pH down motor turns on. Meanwhile, after waiting for 15 seconds, the reads EC values from EC sensor. If the electrical conductivity value is between 800 and 2000 micro Siemens then EC motor remains off and if the value goes below 800 micro Siemens then EC motor turns on. Then after waiting for 10 minutes the system repeats its process from the beginning.

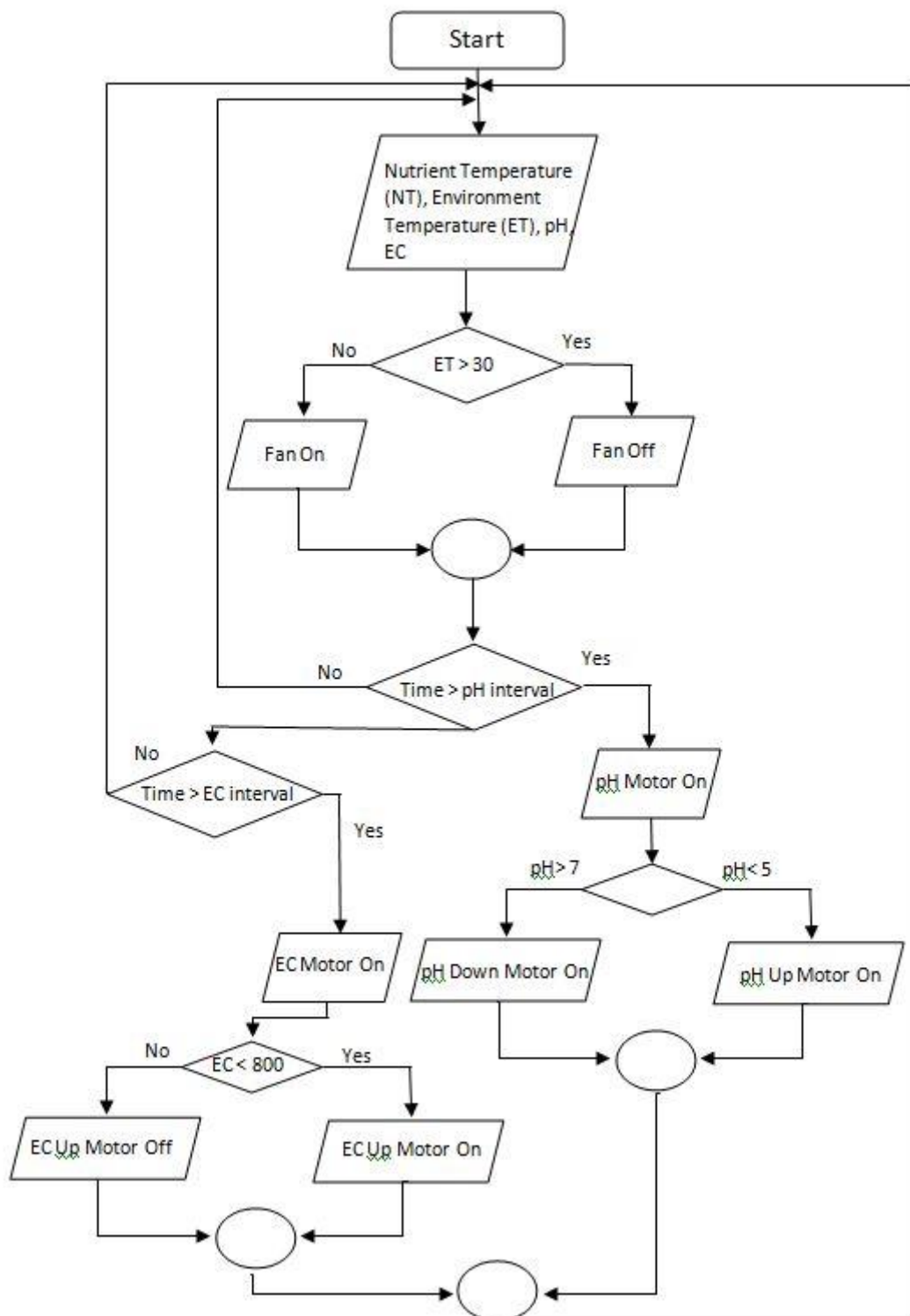

Figure 11: Flow chart of Smart Hydroponic System

### 3.3 ALGORITHM

We have used various sensors for collecting data of hydroponic system. We have also used several water pumps as actuators which controls the system. Using sensor data, the system can balance pH and electrical conductivity of nutrient solution all by itself.

We have given the algorithm below on which our system is based on. From this algorithm, we can understand the system's operating and decision making procedure.

The pseudocode of the smart hydroponic system is:

```
input Solution temperature, environment temperature, pH,  
electrical conductivity  
if environment temperature>30 then  
START FAN  
else FAN OFF  
if pH < 5 then  
START pH Up Motor  
else if pH > 7 then  
START pH Down Motor  
if electrical conductivity < 800 then  
START EC Up Motor  
write Solution temperature, environment temperature,  
humidity, pH and EC  
end
```

Algorithm 1: Smart Hydroponic System

### 3.4 Experimental Setup

This is our whole diagram, we use total one Arduino mega, four sensor, six 12volt motor, seven 5volt relay, one normal 12 volt fan, one Wi-Fi module and a 12volt battery also male to male and male to female jumping wire to connect them.

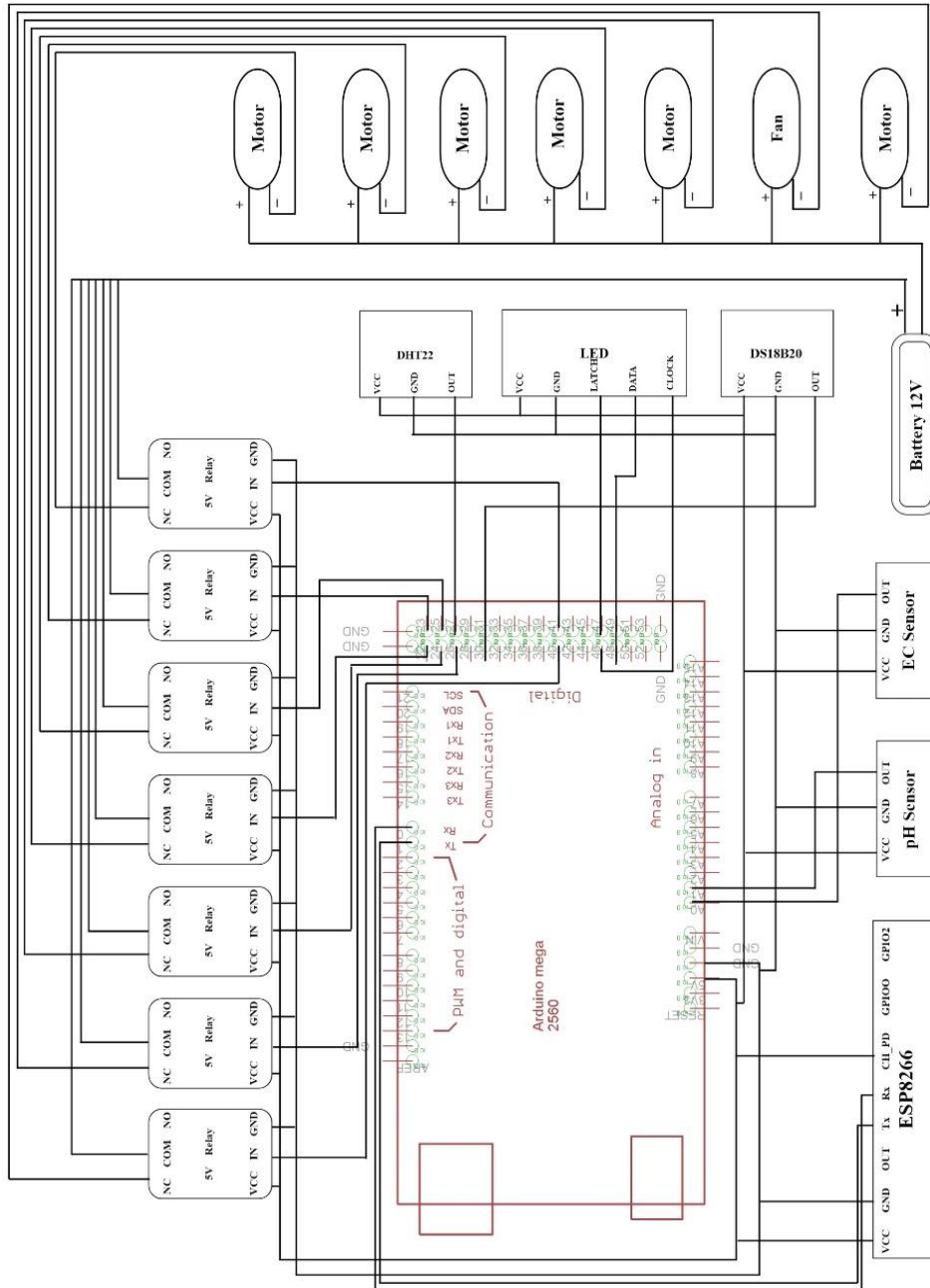

Figure 12: Circuit diagram





Figure 13: Picture of our Smart Hydroponic System.

a) Connection to motor :

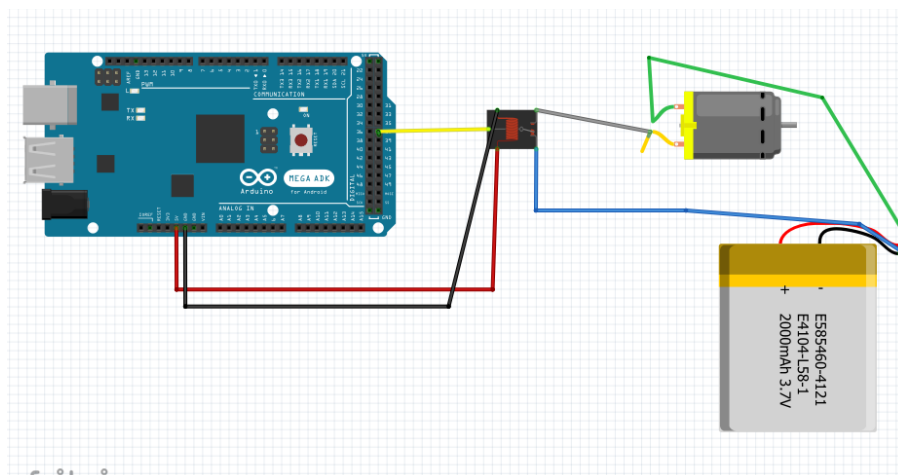

Figure 14: Motor Connection with Arduino

b) Connection to pH sensor :

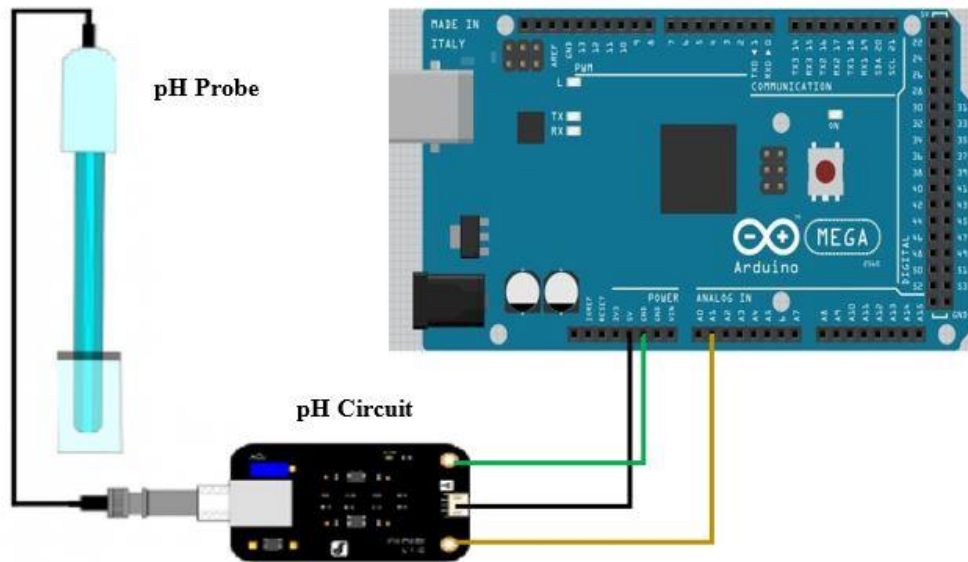

Figure 15: pH Sensor Connection with Arduino

c) Connection to EC sensor :

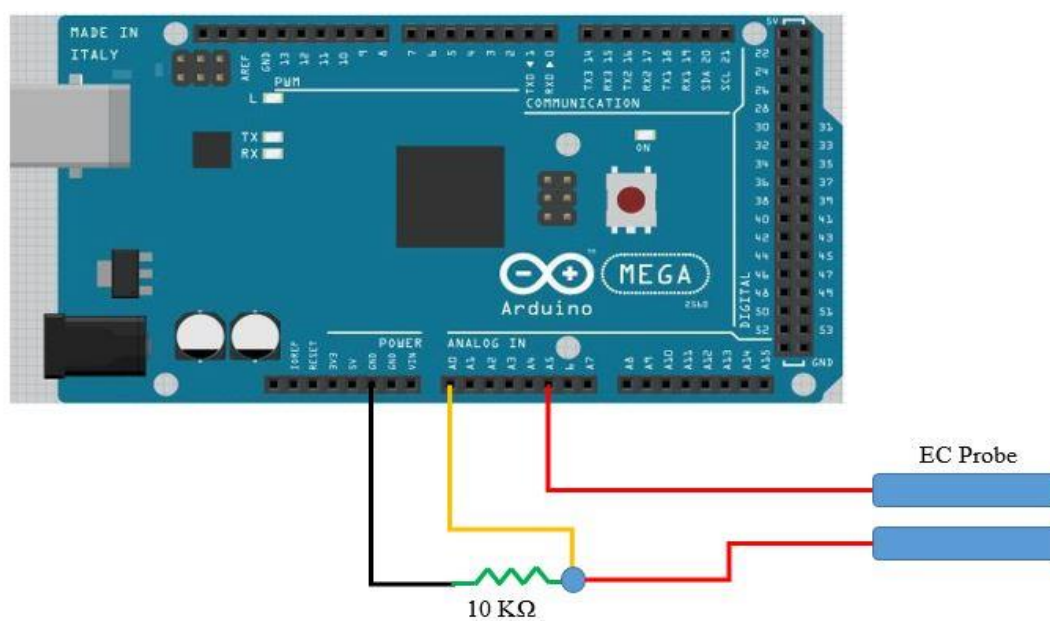

Figure 16: EC Sensor Connection with Arduino

## d) Connection to Humidity and temperature:

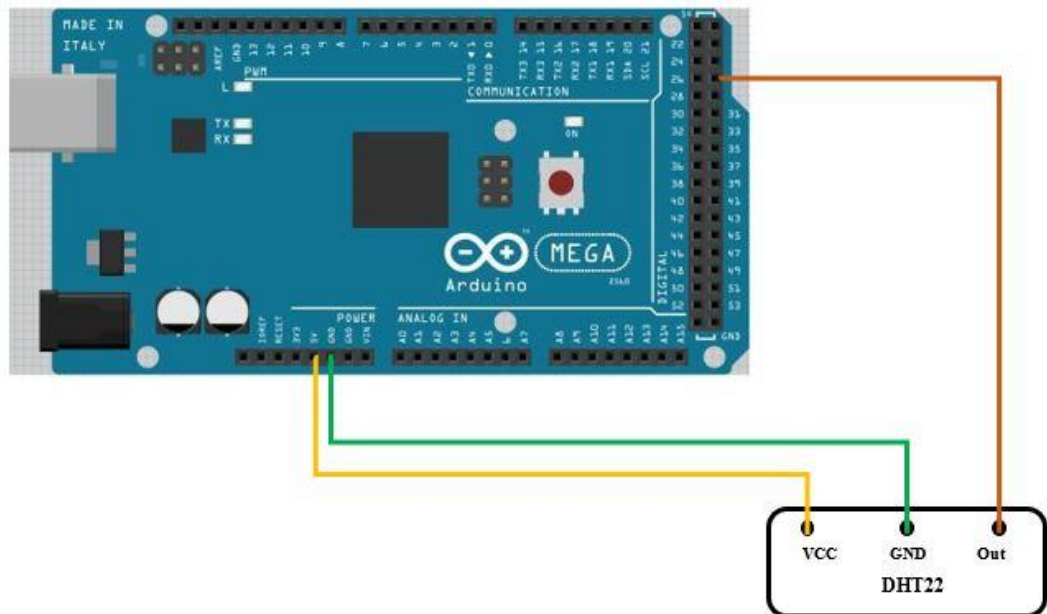

Figure17: DHT22 Connection with Arduino

## e) Connection to water temperature

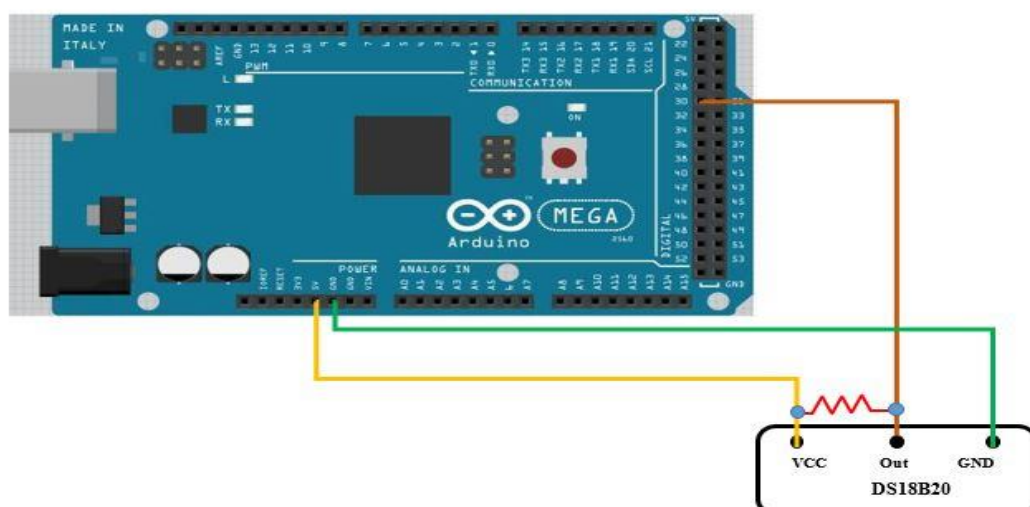

Figure18: DS18B20 connection with Arduino

# Chapter 4

---

## Results and Discussion

### 4.1 INTRODUCTION

In this part of the paper we discussed about collected data of the sensors which are environment temperature, humidity, nutrient solution temperature, electrical conductivity and ph. We used J48 decision tree classification algorithm and K-Nearest Neighbor classification algorithm to analyze the collected data.

### 4.2 RESULT ANALYSIS

In this section, we discussed our collected sensor values [**Appendix A**] using graph. Using graph we can see differences during different time of data collection. Later in this section, we analyzed the sensor data by using J48 classification algorithm and K-Nearest Neighbor classification algorithm by preparing a data set using the collected values. Lastly, we showed a comparative analysis on the classification results.

#### 4.2.1 ANALYSIS USING GRAPH

Sensor data from **Appendix A** is used to plot graphs for analysis. In this graph, we can see the value of solution temperature which are taken between ten minutes interval. Here, we can see that the values didn't deviate suddenly which means sensor value are quite accurate.

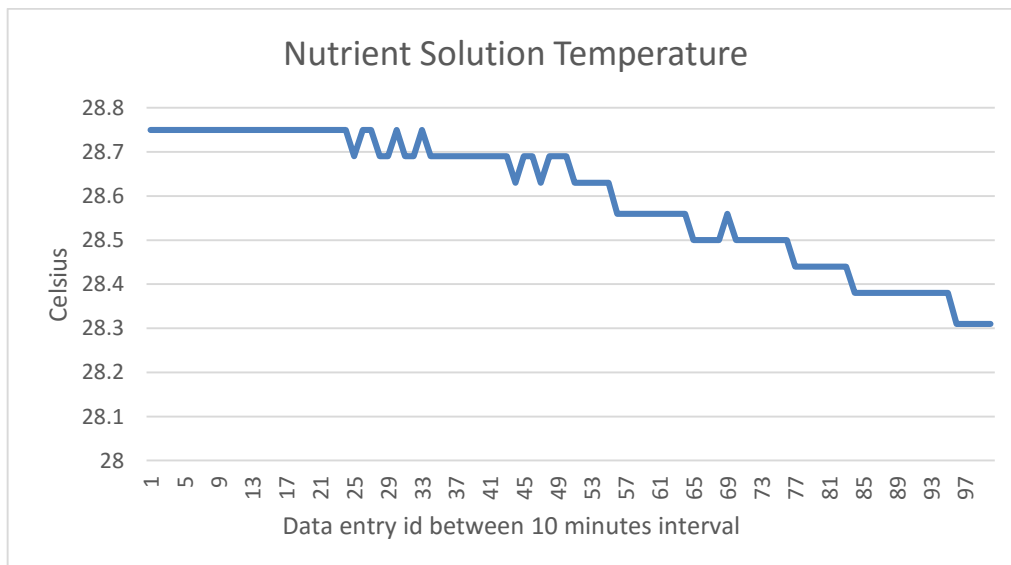

Figure 19: Temperature of nutrient solution

In the below graph we can see a spike where ph value is higher than other values. Then, after adding ph down solution we can see the result where ph value goes to the normal range.

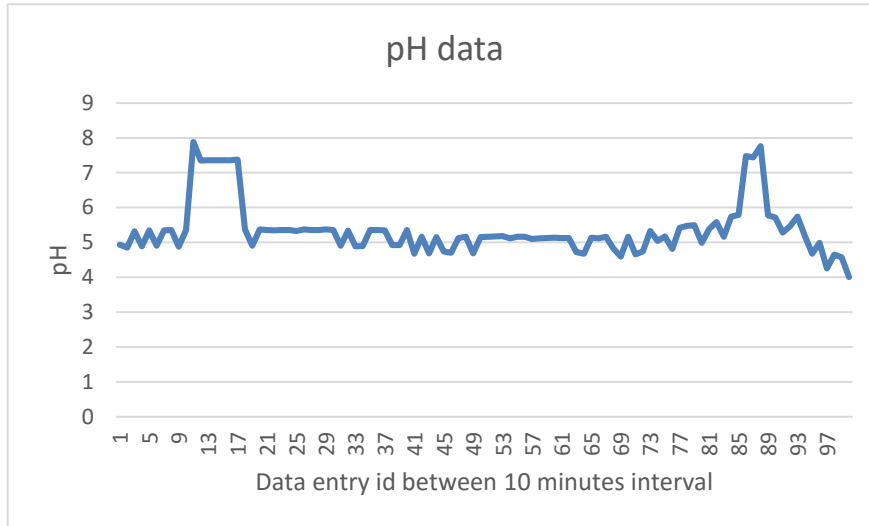

Figure 20: pH values of nutrient solution

In the below graph, we see the temperature value of environment which is decreasing due to temperature control system.

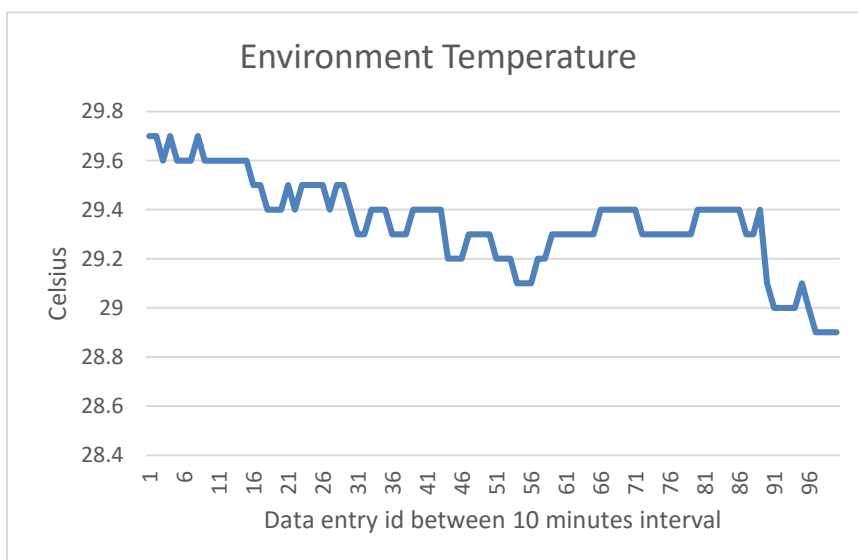

Figure 21: Temperature of Environment

In the below graph, we can see the electrical conductivity is decreasing due to nutrient absorption by plants.

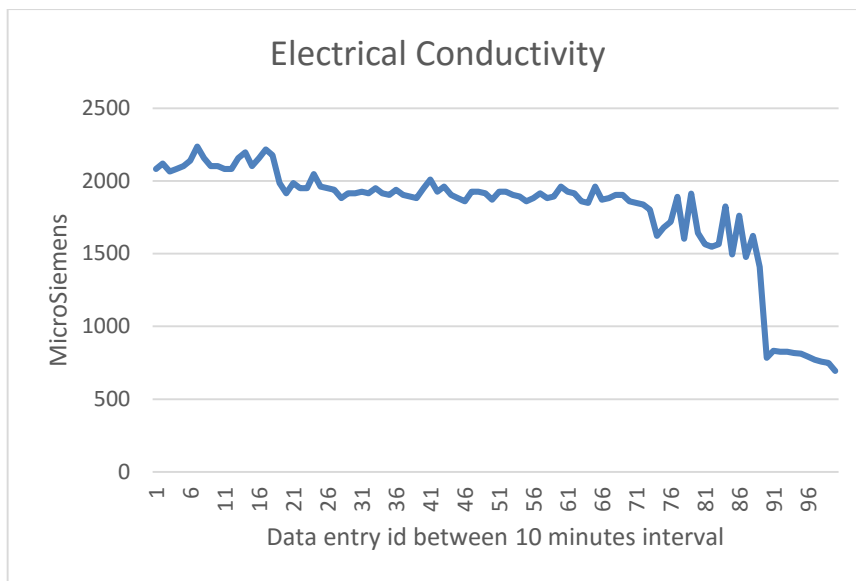

Figure 22: Electrical conductivity of nutrient solution.

In the below graph, we can see the humidity values of the system during experiment.

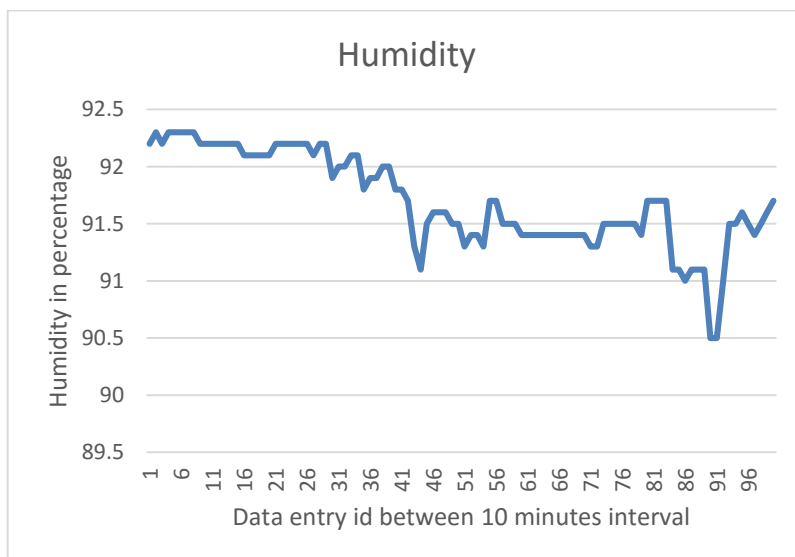

Figure 23: Humidity values of environment

## 4.2.2 ANALYSIS USING CLASSIFICATION ALGORITHMS

In this section, we have used WEKA tool for analyzing data set. Waikato Environment for Knowledge Analysis (Weka) is a suite of machine learning software developed by University of Waikato, Newzealand. It is written in java language [13].

### 4.2.2.1 PERFORMANCE METRICS FOR CLASSIFICATION

In this section, we discussed about performance metrics we used for analysis.

**Cross Validation:** In cross-validation, you decide on a fixed number of folds, or partitions, of the data. Suppose we use n. Then the data is split into approximately n equal partitions; each in turn is used for testing and the remainder is used for training. Repeat the procedure n times so that in the end, every instance has been used exactly once for testing. This is called n-fold cross-validation [14]

**Accuracy:** Accuracy is measured by dividing the total number of correctly classified instances by total number of instances.

**Recall:** Recall (also known as sensitivity) is the fraction of relevant instances that have been retrieved over the total amount of relevant instances.

**Precision:** It is the fraction of relevant instances among the retrieved instances

**TP Rate:**

$$\text{TP Rate} = 100 \times \frac{TP}{TP+FN} \dots\dots\dots (1)$$

Where,

TP Rate = True Positive rate

TP = True Positive

FN = False Negative

**FP Rate:**

$$\text{FP Rate} = 100 \times \frac{FP}{FP+FN} \dots\dots\dots (2)$$

FP Rate = False Positive rate

FP = False Positive

TN = True Negative

**F-Measure:**

$$\text{F-Measure} = \frac{2 \times \text{recall} \times \text{precision}}{\text{recall} + \text{precision}} \dots\dots\dots (3)$$

### 4.2.2.2 DATASET FOR CLASSIFICATION

After collecting result values of different sensors from our system, we prepared our dataset [Appendix B]. We have classified three decision of our system as three separate class and then run classification algorithms separately for each class decision. Then we used, equation (1), (2) and (3) to evaluate performance.

### 4.2.2.3 J48 CLASSIFICATION ALGORITHM

J48 classifier in WEKA tool is based on C4.5 algorithm which is developed by Ross Quinlan. In this algorithm, it first creates a decision tree based on the attribute values of the available training data. Whenever it encounters a set of items (training set) it identifies the attribute that discriminates the various instances clearly. This feature tells about the data instances so that we can classify them the best is said to have the highest information gain. Now, among the possible values of this feature, if there is any value for which there is no ambiguity, that is, for which the data instances falling within its category have the same value for the target variable, then we terminate that branch and assign to it the target value that we have obtained.

Table 4.1: Classification result for class: “ph up” with 5 fold cross validation (1)

Summary	Results
Correctly Classified Instances	99%
Incorrectly Classified Instances	1%
Kappa Statistics	0.9764
Mean Absolute Error	0.0198
Root Mean Squared Error	0.1009
Relative Absolute Error	4.6028%
Root Relative Squared Error	21.7969%
Total Number Of Instances	100

Table 4.2: Classification result for class: “ph up” with 5 fold cross validation (2)

Evaluation Measure	5-Fold Cross Validation
Accuracy	99.0%
TP Rate	99.0%
FP Rate	2.2%
Precision	99.0%
Recall	99.0%
F-Measure	99.0%



Table 4.3: Classification result for class: “ph down” with 5 fold cross validation (1)

Summary	Results
Correctly Classified Instances	99%
Incorrectly Classified Instances	1%
Kappa Statistics	0.9468
Mean Absolute Error	0.01
Root Mean Squared Error	0.1
Relative Absolute Error	5.3247%
Root Relative Squared Error	33.3157%
Total Number Of Instances	100

Table 4.4: Classification result for class: “ph down” with 5 fold cross validation (2)

Evaluation Measure	5-Fold Cross Validation
Accuracy	99.0%
TP Rate	99.0%
FP Rate	0.01%
Precision	99.1%
Recall	99.0%
F-Measure	99.0%

Table 4.5: Classification result for class: “solution up” with 5 fold cross validation (1)

Summary	Results
Correctly Classified Instances	98%
Incorrectly Classified Instances	2%
Kappa Statistics	0.7899
Mean Absolute Error	0.02
Root Mean Squared Error	0.1414
Relative Absolute Error	16.3347%
Root Relative Squared Error	59.3735%
Total Number Of Instances	100

Table 4.6: Classification result for class: “solution up” with 5 fold cross validation (2)

Evaluation Measure	5-Fold Cross Validation
Accuracy	98.0%
TP Rate	99.0%
FP Rate	31.3%
Precision	98.0%
Recall	98.0%
F-Measure	97.8%

Table 4.7: Classification result for class: "ph up" with 70 percent split dataset (1)

Summary	Results
Correctly Classified Instances	100%
Incorrectly Classified Instances	0%
Kappa Statistics	1
Mean Absolute Error	0
Root Mean Squared Error	0
Relative Absolute Error	0%
Root Relative Squared Error	0%
Total Number Of Instances	30

Table 4.8: Classification result for class: "ph up" with 70 percent split dataset (2)

Evaluation Measure	5-Fold Cross Validation
Accuracy	100%
TP Rate	100%
FP Rate	0%
Precision	100%
Recall	100%
F-Measure	100%

Table 4.9: Classification result for class: "ph down" with 70 percent split dataset (1)

Summary	Results
Correctly Classified Instances	100%
Incorrectly Classified Instances	0%
Kappa Statistics	1
Mean Absolute Error	0
Root Mean Squared Error	0
Relative Absolute Error	0%
Root Relative Squared Error	0%
Total Number Of Instances	30

Table 4.10: Classification result for class: "ph down" with 70 percent split dataset (2)

Evaluation Measure	5-Fold Cross Validation
Accuracy	100%
TP Rate	100%
FP Rate	0%
Precision	100%
Recall	100%
F-Measure	100%

Table 4.11: Classification result for class: “solution up” with 70 percent split dataset (1)

Summary	Results
Correctly Classified Instances	96.67%
Incorrectly Classified Instances	3.33%
Kappa Statistics	0.6512
Mean Absolute Error	0.0333
Root Mean Squared Error	0.1826
Relative Absolute Error	26.2774%
Root Relative Squared Error	73.188%
Total Number Of Instances	30

Table 4.12: Classification result for class: “solution up” with 70 percent split dataset (2)

Evaluation Measure	5-Fold Cross Validation
Accuracy	96.7%
TP Rate	96.7%
FP Rate	46.7%
Precision	96.8%
Recall	96.7%
F-Measure	96.1%

#### 4.2.2.4 K-Nearest Neighbor CLASSIFICATION ALGORITHM

The k-Nearest-Neighbours (kNN) is a non-parametric classification method, which is simple but effective in many cases. For a data record  $t$  to be classified, its  $k$  nearest neighbours are retrieved, and this forms a neighbourhood of  $t$ . Majority voting among the data records in the neighbourhood is usually used to decide the classification for  $t$  with or without consideration of distance-based weighting. However, to apply kNN we need to choose an appropriate value for  $k$ , and the success of classification is very much dependent on this value. In a sense, the kNN method is biased by  $k$ . There are many ways of choosing the  $k$  value, but a simple one is to run the algorithm many times with different  $k$  values and choose the one with the best performance [15].

Table 4.13: Classification result for class: "ph up" with 5 fold cross validation, K=3 (1)

Summary	Results
Correctly Classified Instances	84%
Incorrectly Classified Instances	16%
Kappa Statistics	0.5729
Mean Absolute Error	0.2091
Root Mean Squared Error	0.3492
Relative Absolute Error	48.6534%
Root Relative Squared Error	75.4554%
Total Number Of Instances	100

Table 4.14: Classification result for class: "ph up" with 5 fold cross validation, K=3 (2)

Evaluation Measure	5-Fold Cross Validation
Accuracy	84.0%
TP Rate	84.0%
FP Rate	33.8%
Precision	85.7%
Recall	84.0%
F-Measure	82.4%

Table 4.15: Classification result for class: "ph down" with 5 fold cross validation, K=3 (1)

Summary	Results
Correctly Classified Instances	97%
Incorrectly Classified Instances	3%
Kappa Statistics	0.8077
Mean Absolute Error	0.0306
Root Mean Squared Error	0.1411
Relative Absolute Error	16.2821%
Root Relative Squared Error	47.0052%
Total Number Of Instances	100

Table 4.16: Classification result for class: "ph down" with 5 fold cross validation, K=3 (2)

Evaluation Measure	5-Fold Cross Validation
Accuracy	97.0%
TP Rate	97.0%
FP Rate	27.0%
Precision	97.1%
Recall	97.0%
F-Measure	96.8%

Table 4.17: Classification result for class: "solution up" with 5 fold cross validation, K=3 (1)

Summary	Results
Correctly Classified Instances	98%
Incorrectly Classified Instances	2%
Kappa Statistics	0.8227
Mean Absolute Error	0.0339
Root Mean Squared Error	0.1524
Relative Absolute Error	27.6744%
Root Relative Squared Error	63.9641%
Total Number Of Instances	100

Table 4.18: Classification result for class: "solution up" with 5 fold cross validation, K=3 (2)

Evaluation Measure	5-Fold Cross Validation
Accuracy	98.0%
TP Rate	98.0%
FP Rate	15.7%
Precision	98.0%
Recall	98.0%
F-Measure	98.0%

Table 4.19: Classification result for class: "ph up" with 70 percent split dataset, K=3 (1)

Summary	Results
Correctly Classified Instances	86.67%
Incorrectly Classified Instances	13.33%
Kappa Statistics	0.6296
Mean Absolute Error	0.1808
Root Mean Squared Error	0.3216
Relative Absolute Error	42.8252%
Root Relative Squared Error	71.9166%
Total Number Of Instances	30

Table 4.20: Classification result for class: "ph up" with 70 percent split dataset, K=3 (2)

Evaluation Measure	5-Fold Cross Validation
Accuracy	86.67%
TP Rate	86.7%
FP Rate	28.7%
Precision	86.4%
Recall	86.7%
F-Measure	86.0%

Table 4.21: Classification result for class: "ph down" with 70 percent split dataset, K=3 (1)

Summary	Results
Correctly Classified Instances	100%
Incorrectly Classified Instances	0%
Kappa Statistics	1
Mean Absolute Error	0.0157
Root Mean Squared Error	0.0613
Relative Absolute Error	8.3241%
Root Relative Squared Error	20.4262%
Total Number Of Instances	30

Table 4.22: Classification result for class: "ph down" with 70 percent split dataset, K=3 (2)

Evaluation Measure	5-Fold Cross Validation
Accuracy	100%
TP Rate	100%
FP Rate	0%
Precision	100%
Recall	100%
F-Measure	100%

Table 4.23: Classification result for class: "solution up" with 70 percent split dataset, K=3 (1)

Summary	Results
Correctly Classified Instances	100%
Incorrectly Classified Instances	0%
Kappa Statistics	1
Mean Absolute Error	0.0267
Root Mean Squared Error	0.0866
Relative Absolute Error	21.0715%
Root Relative Squared Error	34.712%
Total Number Of Instances	30

Table 4.24: Classification result for class: "solution up" with 70 percent split dataset, K=3 (2)

Evaluation Measure	5-Fold Cross Validation
Accuracy	100%
TP Rate	100%
FP Rate	0%
Precision	100%
Recall	100%
F-Measure	100%

#### 4.2.2.5 COMPARISON OF CLASSIFICATION RESULTS

A graph has been plotted using 5-fold cross validation classification results of J48 and K-Nearest neighbor (K=3) classifier which are shown in Figure#. The blue series is the accuracy of the classifiers on the provided dataset and the orange series is the precision of the classifiers on the provided dataset.

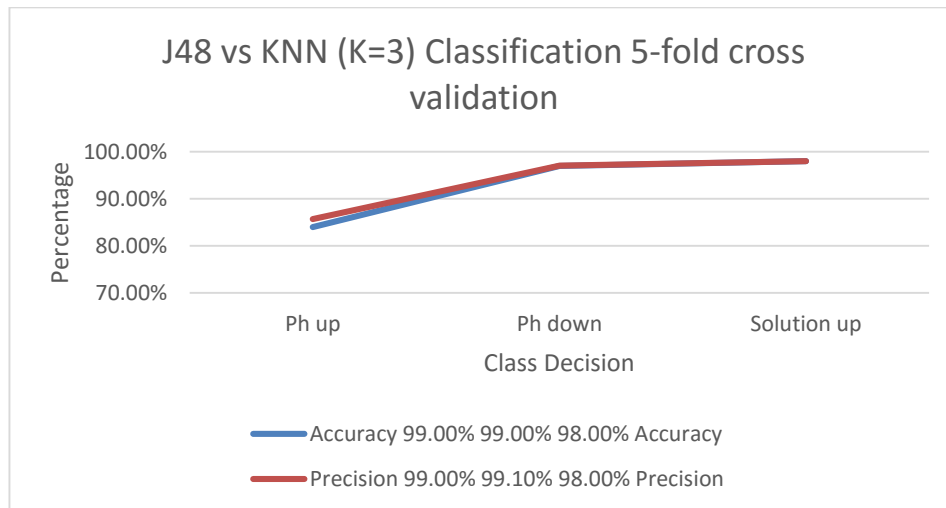

Figure 24: J48 vs KNN (K=3) with 5-fold cross validation classification results comparison.

A graph has been plotted using 70 percent split dataset classification results of J48 and K-Nearest neighbor (K=3) classifier which are shown in Figure#. The blue series is the accuracy of the classifiers on the provided dataset and the orange series is the precision of the classifiers on the provided dataset.

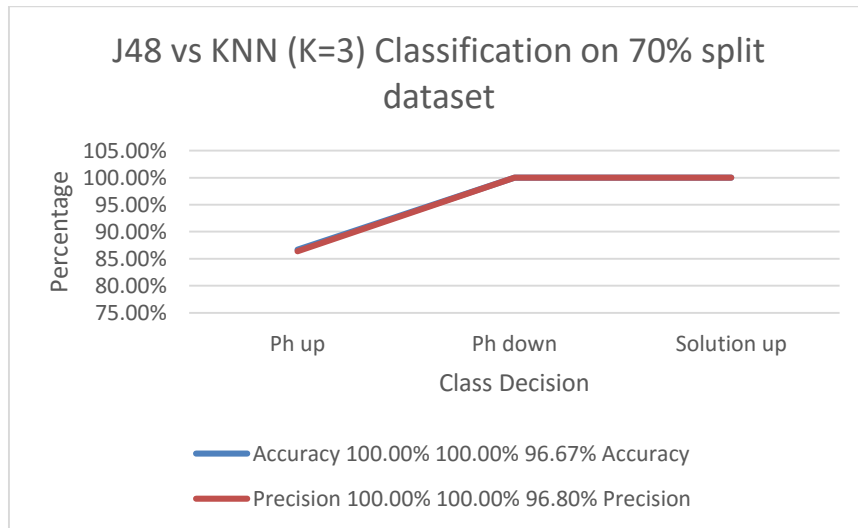

Figure 25: J48 vs KNN (K=3) with 70 percent split dataset classification results comparison.

Both of the graph concludes that, our smart hydroponic farming system generated data are accurate and it can take accurate decision based on sensor's values.



# Chapter 5

---

## Conclusion

### 5.1 CONCLUSION

The proposed research work provides smart hydroponic farming system using various sensors. Experiments have been conducted with the system. Various data are recorded through cloud server using ThingSpeak cloud platform. All data are recorded in xml,json and csv format. The system used environment temperature, humidity, nutrient solution temperature, ph and electrical conductivity values to monitor and execute commands through actuators. This methodology gives accuracy and also provide cost-efficient farming for farmers/home growers. The system provides an automated solution for hydroponic farming where maintenance is always higher priority. As the real-time sensor data are uploaded to cloud server, farmers can also monitor real-time situation of their hydroponic system through internet.

Since the proposed system requires small area for set up, agricultural production can be greatly increased with this method. A smart hydroponic system can help farmers grow more using less land and other resources. They don't need to spend money on pesticides and use a lot of water for irrigation. Everything is controlled in this system. So, only a precise amount is spent on overall farming cost without any waste. Though Hydroponic provides more harvest using less resources it is still not so popular method among farmers because of a farmer needs to have various knowledge about ph, electrical conductivity and other things. But since the proposed system is autonomous, it reduces this obstacle of knowing ph, electrical conductivity and other things.

In this paper, we have designed and implemented a smart hydroponic agriculture system with a view to increase the agricultural productivity and reduce the problems of land limitation, climate change and other resource limitations.

## **5.2 FUTURE WORK**

Future work would focus on developing a framework where artificial intelligence can be used to determine the action of actuators. Our aim is to use sensor data from cloud and by using artificial intelligence our system can give more accurate decision and predict various data like production quantity, the time of harvesting or any system malfunction. Then the system can be used without any human interaction. We also aim to work on ph sensor and electrical conductivity sensor for solving ground loop problem to use them together simultaneously in our system.

---

## Bibliography

1. Food and Agriculture Organization of the United Nation|FAO's role in livestock and the environment [Online] Available at <http://www.fao.org/livestock-environment/en/> [Last Accessed at 30 August, 2018].
2. Professor Duncan Cameron, Professor Colin Osborne, Professor Peter Horton FRS, Mark Sinclair, "A Sustainable Model for Intensive Agriculture".
3. Winfried E. H. Blum, "Soil and Land Resources for Agricultural Production: General Trends and Future Scenarios-A Worldwide Perspective", International Soil and Water Conservation Research, Volume 1, Issue 3, December 2013, Pages 1-14.
4. The Land Resource for Agriculture, P. Buringh, philosophical Transactions of the Royal Society of London. Series B, Biological Sciences Vol. 310, No. 1144, Technology in the 1990s: Agriculture and Food (Sep. 12, 1985), pp. 151
5. Carlos E. Ludena , Carla Mejia, "Climate Change, Agricultural Productivity and its Impacts on the Food Industry: A General Equilibrium Analysis", International Association of Agricultural Economists (IAAE) Triennial Conference, Foz do Iguacu, Brazil, 18-24 August, 2012.
6. Keith Roberto, How to Hydroponics, 4th Edition, Page-23.
7. Somchoke Ruengittinun, Sitthidech Phongsamsuan, Phasawut Sureeratanakorn, "Applied Internet of Thing for Smart Hydroponic Farming Ecosystem (HFE)", 2017, 10th International Conference on Ubi-media Computing and Workshops (Ubi-Media).
8. Padma Nyoman Crisnapati, Nyoman Kusuma Wardana, Komang Agus Ady Aryanto, Agus Hermawan, "Hommons: Hydroponic Management and Monitoring System for an IOT Based NFT Farm Using Web Technology".
9. Yakub Eka Nugraha, Budhi Irawan, Randy Erfa Saputra, "System Design And Implementation Automation System of Expert System on Hydroponics Nutrients Control Using Forward Chaining Method", The 2017 IEEE Asia Pacific Conference on Wireless and Mobile (APWiMob).
10. Dania Eridani, Olivia Wardhani, Eko Didik Widiyanto, "Designing and Implementing the Arduino-based Nutrition Feeding Automation System of a Prototype Scaled Nutrient Film Technique (NFT) Hydroponic using Total Dissolved Solids (TDS) Sensor".
11. Arduino mega Atmega256 [Online] Available at <https://www.arduino.cc/en/Main/arduinoBoardMega/> [Last Accessed at 30 August, 2018].
12. pH sensor [Online] Available at [http://www.coastalwiki.org/wiki/PH\\_sensors](http://www.coastalwiki.org/wiki/PH_sensors) [Last Accessed at 30 August, 2018].

13. Weka tool [Online] Available at <https://www.cs.waikato.ac.nz/ml/weka/> [Last Accessed at 30 August, 2018].
14. Ian H. Witten, Eibe Frank, Mark A. Hall, “Data Mining - Practical Machine Learning Tools and Techniques (3rd)”, Chapter 5.
15. Gongde Guo, Hui Wang, David Bell, Yaxin Bi and Kieran Greer, “KNN Model-Based Approach in Classification”.
16. Home Hydroponics, Ruth Sorenson, Diane Relf, Horticulture, Virginia Tech, VCE Publications / 426 / 426-084.
17. Emily Gertz, Patrick Di Justo, “Environmental Monitoring with Arduino”, Chapter-5.
18. Bangladesh Agricultural Research Institute, “Garden Cultivation of Crop Using Hydroponic Method”.

# Appendix A

---

## Sensor's Data

Entry id	Solution Temperature (Celsius)	PH	Environment Temperature (Celsius)	Electrical Conductivity (micro Siemens)	Humidity
4	28.75	4.93	29.7	2082.46	92.2
5	28.75	4.85	29.7	2119.62	92.3
6	28.75	5.32	29.6	2064.15	92.2
7	28.75	4.89	29.7	2082.46	92.3
8	28.75	5.35	29.6	2100.95	92.3
9	28.75	4.91	29.6	2138.46	92.3
10	28.75	5.35	29.6	2235.47	92.3
11	28.75	5.36	29.7	2157.49	92.3
12	28.75	4.88	29.6	2100.95	92.2
13	28.75	5.36	29.6	2100.95	92.2
14	28.75	7.88	29.6	2082.46	92.2
15	28.75	7.35	29.6	2082.46	92.2
16	28.75	7.36	29.6	2157.49	92.2
17	28.75	7.36	29.6	2196.1	92.2
18	28.75	7.36	29.6	2100.95	92.2
19	28.75	7.36	29.5	2157.49	92.1
20	28.75	7.38	29.5	2215.69	92.1
21	28.75	5.37	29.4	2176.7	92.1
22	28.75	4.91	29.4	1985.44	92.1
23	28.75	5.37	29.4	1915.09	92.1
24	28.75	5.36	29.5	1985.44	92.2
25	28.75	5.35	29.4	1949.76	92.2
26	28.75	5.36	29.5	1949.76	92.2
27	28.75	5.36	29.5	2047.26	92.2
28	28.69	5.33	29.5	1961.54	92.2
29	28.75	5.37	29.5	1949.76	92.2
30	28.75	5.36	29.4	1938.1	92.1
31	28.69	5.36	29.5	1881.4	92.2
32	28.69	5.37	29.5	1915.09	92.2
33	28.75	5.36	29.4	1915.09	91.9
34	28.69	4.91	29.3	1926.54	92
35	28.69	5.34	29.3	1915.09	92
36	28.75	4.89	29.4	1949.76	92.1
37	28.69	4.9	29.4	1915.09	92.1
38	28.69	5.36	29.4	1903.76	91.8
39	28.69	5.36	29.3	1938.1	91.9
40	28.69	5.35	29.3	1903.76	91.9
41	28.69	4.92	29.3	1892.52	92

42	28.69	4.92	29.4	1881.4	92
43	28.69	5.36	29.4	1949.76	91.8
44	28.69	4.68	29.4	2009.8	91.8
45	28.69	5.16	29.4	1926.54	91.7
46	28.69	4.69	29.4	1961.54	91.3
47	28.63	5.15	29.2	1903.76	91.1
48	28.69	4.74	29.2	1881.4	91.5
49	28.69	4.7	29.2	1859.45	91.6
50	28.63	5.13	29.3	1926.54	91.6
51	28.69	5.16	29.3	1926.54	91.6
52	28.69	4.69	29.3	1915.09	91.5
53	28.69	5.15	29.3	1870.37	91.5
54	28.63	5.16	29.2	1926.54	91.3
55	28.63	5.17	29.2	1926.54	91.4
56	28.63	5.18	29.2	1903.76	91.4
57	28.63	5.12	29.1	1892.52	91.3
58	28.63	5.16	29.1	1859.45	91.7
59	28.56	5.16	29.1	1881.4	91.7
60	28.56	5.1	29.2	1915.09	91.5
61	28.56	5.12	29.2	1881.4	91.5
62	28.56	5.13	29.3	1892.52	91.5
63	28.56	5.14	29.3	1961.54	91.4
64	28.56	5.13	29.3	1926.54	91.4
65	28.56	5.13	29.3	1915.09	91.4
66	28.56	4.72	29.3	1859.45	91.4
67	28.56	4.68	29.3	1848.62	91.4
68	28.5	5.14	29.3	1961.54	91.4
69	28.5	5.12	29.4	1870.37	91.4
70	28.5	5.16	29.4	1881.4	91.4
71	28.5	4.82	29.4	1903.76	91.4
72	28.56	4.59	29.4	1903.76	91.4
73	28.5	5.16	29.4	1859.45	91.4
74	28.5	4.66	29.4	1848.62	91.3
75	28.5	4.74	29.3	1837.9	91.3
76	28.5	5.33	29.3	1803.23	91.5
77	28.5	5.04	29.3	1621.95	91.5
78	28.5	5.17	29.3	1680.12	91.5
79	28.5	4.81	29.3	1720.13	91.5
80	28.44	5.42	29.3	1890.73	91.5
81	28.44	5.48	29.3	1603.03	91.5
82	28.44	5.49	29.3	1913.33	91.4
83	28.44	4.99	29.4	1641.1	91.7
84	28.44	5.38	29.4	1565.87	91.7
85	28.44	5.59	29.4	1547.62	91.7
86	28.44	5.16	29.4	1565.87	91.7

87	28.38	5.74	29.4	1824.68	91.1
88	28.38	5.79	29.4	1494.15	91.1
89	28.38	7.48	29.4	1761.15	91
90	28.38	7.44	29.3	1476.74	91.1
91	28.38	7.76	29.3	1621.95	91.1
92	28.38	5.78	29.4	1409.09	91.1
93	28.38	5.71	29.1	783.21	90.5
94	28.38	5.28	29	833.33	90.5
95	28.38	5.47	29	826.42	91
96	28.38	5.74	29	826.42	91.5
97	28.38	5.19	29	816.2	91.5
98	28.38	4.68	29.1	812.82	91.6
99	28.31	4.99	29	792.93	91.5
100	28.31	4.25	28.9	770.47	91.4
101	28.31	4.65	28.9	757.99	91.5
102	28.31	4.58	28.9	748.78	91.6
103	28.31	4.01	28.9	693.47	91.7

## Appendix B

---

### Dataset For classification

Entry id	Solution Temperature (Celsius)	PH	Environment Temperature (Celsius)	Electrical Conductivity (micro Siemens)	Humidity	pH up	pH down	Solution up
4	28.75	4.93	29.7	2082.46	92.2	yes	no	no
5	28.75	4.85	29.7	2119.62	92.3	yes	no	no
6	28.75	5.32	29.6	2064.15	92.2	no	no	no
7	28.75	4.89	29.7	2082.46	92.3	yes	no	no
8	28.75	5.35	29.6	2100.95	92.3	no	no	no
9	28.75	4.91	29.6	2138.46	92.3	yes	no	no
10	28.75	5.35	29.6	2235.47	92.3	no	no	no
11	28.75	5.36	29.7	2157.49	92.3	no	no	no
12	28.75	4.88	29.6	2100.95	92.2	yes	no	no
13	28.75	5.36	29.6	2100.95	92.2	no	no	no
14	28.75	7.88	29.6	2082.46	92.2	yes	yes	no
15	28.75	7.35	29.6	2082.46	92.2	no	yes	no
16	28.75	7.36	29.6	2157.49	92.2	no	yes	no
17	28.75	7.36	29.6	2196.1	92.2	no	yes	no
18	28.75	7.36	29.6	2100.95	92.2	no	yes	no
19	28.75	7.36	29.5	2157.49	92.1	no	yes	no
20	28.75	7.38	29.5	2215.69	92.1	no	yes	no
21	28.75	5.37	29.4	2176.7	92.1	no	no	no
22	28.75	4.91	29.4	1985.44	92.1	yes	no	no
23	28.75	5.37	29.4	1915.09	92.1	no	no	no
24	28.75	5.36	29.5	1985.44	92.2	no	no	no
25	28.75	5.35	29.4	1949.76	92.2	no	no	no
26	28.75	5.36	29.5	1949.76	92.2	no	no	no
27	28.75	5.36	29.5	2047.26	92.2	no	no	no
28	28.69	5.33	29.5	1961.54	92.2	no	no	no
29	28.75	5.37	29.5	1949.76	92.2	no	no	no
30	28.75	5.36	29.4	1938.1	92.1	no	no	no
31	28.69	5.36	29.5	1881.4	92.2	no	no	no
32	28.69	5.37	29.5	1915.09	92.2	no	no	no
33	28.75	5.36	29.4	1915.09	91.9	no	no	no
34	28.69	4.91	29.3	1926.54	92	yes	no	no
35	28.69	5.34	29.3	1915.09	92	no	no	no
36	28.75	4.89	29.4	1949.76	92.1	yes	no	no
37	28.69	4.9	29.4	1915.09	92.1	yes	no	no
38	28.69	5.36	29.4	1903.76	91.8	no	no	no
39	28.69	5.36	29.3	1938.1	91.9	no	no	no
40	28.69	5.35	29.3	1903.76	91.9	no	no	no
41	28.69	4.92	29.3	1892.52	92	yes	no	no
42	28.69	4.92	29.4	1881.4	92	yes	no	no
43	28.69	5.36	29.4	1949.76	91.8	no	no	no



44	28.69	4.68	29.4	2009.8	91.8	yes	no	no
45	28.69	5.16	29.4	1926.54	91.7	no	no	no
46	28.69	4.69	29.4	1961.54	91.3	yes	no	no
47	28.63	5.15	29.2	1903.76	91.1	no	no	no
48	28.69	4.74	29.2	1881.4	91.5	yes	no	no
49	28.69	4.7	29.2	1859.45	91.6	yes	no	no
50	28.63	5.13	29.3	1926.54	91.6	no	no	no
51	28.69	5.16	29.3	1926.54	91.6	no	no	no
52	28.69	4.69	29.3	1915.09	91.5	yes	no	no
53	28.69	5.15	29.3	1870.37	91.5	no	no	no
54	28.63	5.16	29.2	1926.54	91.3	no	no	no
55	28.63	5.17	29.2	1926.54	91.4	no	no	no
56	28.63	5.18	29.2	1903.76	91.4	no	no	no
57	28.63	5.12	29.1	1892.52	91.3	no	no	no
58	28.63	5.16	29.1	1859.45	91.7	no	no	no
59	28.56	5.16	29.1	1881.4	91.7	no	no	no
60	28.56	5.1	29.2	1915.09	91.5	no	no	no
61	28.56	5.12	29.2	1881.4	91.5	no	no	no
62	28.56	5.13	29.3	1892.52	91.5	no	no	no
63	28.56	5.14	29.3	1961.54	91.4	no	no	no
64	28.56	5.13	29.3	1926.54	91.4	no	no	no
65	28.56	5.13	29.3	1915.09	91.4	no	no	no
66	28.56	4.72	29.3	1859.45	91.4	yes	no	no
67	28.56	4.68	29.3	1848.62	91.4	yes	no	no
68	28.5	5.14	29.3	1961.54	91.4	no	no	no
69	28.5	5.12	29.4	1870.37	91.4	no	no	no
70	28.5	5.16	29.4	1881.4	91.4	no	no	no
71	28.5	4.82	29.4	1903.76	91.4	yes	no	no
72	28.56	4.59	29.4	1903.76	91.4	yes	no	no
73	28.5	5.16	29.4	1859.45	91.4	no	no	no
74	28.5	4.66	29.4	1848.62	91.3	yes	no	no
75	28.5	4.74	29.3	1837.9	91.3	yes	no	no
76	28.5	5.33	29.3	1803.23	91.5	no	no	no
77	28.5	5.04	29.3	1621.95	91.5	no	no	no
78	28.5	5.17	29.3	1680.12	91.5	no	no	no
79	28.5	4.81	29.3	1720.13	91.5	yes	no	no
80	28.44	5.42	29.3	1890.73	91.5	no	no	no
81	28.44	5.48	29.3	1603.03	91.5	no	no	no
82	28.44	5.49	29.3	1913.33	91.4	no	no	no
83	28.44	4.99	29.4	1641.1	91.7	yes	no	no
84	28.44	5.38	29.4	1565.87	91.7	no	no	no
85	28.44	5.59	29.4	1547.62	91.7	no	no	no
86	28.44	5.16	29.4	1565.87	91.7	no	no	no
87	28.38	5.74	29.4	1824.68	91.1	no	no	no
88	28.38	5.79	29.4	1494.15	91.1	no	no	no
89	28.38	7.48	29.4	1761.15	91	no	yes	no
90	28.38	7.44	29.3	1476.74	91.1	no	yes	no
91	28.38	7.76	29.3	1621.95	91.1	no	yes	no
92	28.38	5.78	29.4	1409.09	91.1	no	no	no
93	28.38	5.71	29.1	783.21	90.5	no	no	yes
94	28.38	5.28	29	833.33	90.5	no	no	no

95	28.38	5.47	29	826.42	91	no	no	no
96	28.38	5.74	29	826.42	91.5	no	no	no
97	28.38	5.19	29	816.2	91.5	no	no	no
98	28.38	4.68	29.1	812.82	91.6	yes	no	no
99	28.31	4.99	29	792.93	91.5	yes	no	yes
100	28.31	4.25	28.9	770.47	91.4	yes	no	yes
101	28.31	4.65	28.9	757.99	91.5	yes	no	yes
102	28.31	4.58	28.9	748.78	91.6	yes	no	yes
103	28.31	4.01	28.9	693.47	91.7	yes	no	yes