

**EAST
WEST
UNIVERSITY**



East West University

Department of Electronics and Communications Engineering

Course Code: ICE498

Course Title: Undergraduate Research Project

Title

“Study on IEEE 802.11ad 60 GHz mmWave Channel Access

Scheme and Its Implementation in ns-3”

Supervisor

Dr. Mohammad Arifuzzaman
Assistant Professor

Submitted by:

Md Al-Imran
ID: 2016-1-50-021

Fall 2019

Declaration

I hereby declare that, I completed my thesis on the topic entitled **Study on IEEE 802.11ad 60 GHz mmWave Channel Access Scheme and Its Implementation in ns-3**. I prepared the thesis report and submitted to the Department of Electronics and Communications Engineering. This paper is submitted to fulfill the requirement of the degree B.Sc Engineering in Information and Communications Engineering.

I claim that the thesis work which is demonstrated in this report is my own work. We also declare that this work has not been submitted anywhere for publication.

Md Al-Imran

ID: 2016-1-50-021

Signature of Supervisor

Dr. Mohammad Arifuzzaman

Assistant Professor

Dept. of ECE

East West University

Acknowledgment

First of all, I am grateful to almighty Allah for blessing us to successfully complete the task.

A special thanks with honor to my supervisor Dr. Mohammad Arifuzzaman for giving us their valuable time, guidance, motivation, thought and encouragement which lead me to success.

I am also pleased to all our faculty members of ECE department for their guidance and support to complete our graduation degree. I also expressing my thankfulness to my friends who supported me a lot at my critical situation.

A special thanks to my family members whose encouragement and prayer are always with me.

Thank you all for always supporting me.

Md Al-Imran

Approval

This report on **Study on IEEE 802.11ad 60 GHz mmWave Channel Access Scheme and Its Implementation in ns-3**, submitted by Md Al-Imran, ID: 2016-1-50-021, to Dept. of ECE, East West University. It is submitted in partial fulfillment of the requirement for the degree of B.Sc Engineering in Information and Communications Engineering.

Dr. Mohammed Moseeur Rahman

Assistant Professor,
Chairperson,
Department of ECE,
East West University

Abstract

In this paper, realizing the significance of mmWave communication, we perform the research on 5G Wireless Local Area Network (WLAN). Specifically, WLAN in 5G is supposed to be according to the IEEE 802.11ad amendment. Focusing on 60 GHz mmWave communication, there is MAC modified based on the ecosystem of actual IEEE 802.11 standard. In IEEE 802.11ad, communication get interrupted because of various type obstruction. Therefore, there is need for channel in between source and destination which uses techniques to access the medium. So, this study performs the simulation analysis of the channel access scheme performance evaluation in ns-3.

Table of Contents

Chapter Name -----	Page Number
Declaration -----	i
Acknowledgment-----	ii
Approval-----	iii
Abstract -----	iv
Chapter One: Introduction-----	1
Chapter Two: Related Work-----	3
Chapter Three: IEEE 802.11 Standard -----	5
3.1 Physical Layer -----	8
3.1.1 Direct Sequence Spread Spectrum (DSSS)-----	8
3.1.2 Orthogonal Frequency Division Multiplexing (OFDM)-----	9
3.1.2 Data Modulation and Coding Combinations -----	10
3.2 MEDIUM ACCESS CONTROL -----	10
Chapter Four: Fundamentals of Millimeter Wave -----	13
4.1 Spectrum Regulation Overview-----	13
4.2 Millimeter Wave Propagation-----	15
Chapter Five: Directional Multigigabit – IEEE 802.11ad-----	19
5.1 DMG PHY Layer-----	20
5.1.1 DMG PHY Frame Structure-----	21
5.1.1.1 Preamble -----	22

5.1.1.2 Header -----	25
5.2 Medium Access Control -----	26
Chapter Six: ns-3 Implementation and Simulation Analysis-----	30
6.1.1 WLAN Simulation -----	32
6.2 IEEE 802.11ad Channel Access Scheme Simulation -----	33
6.3 Channel Access Schemes of IEEE 802.11ad -----	35
6.3.1 CSMA/CA -----	35
6.3.2 Scheduled Service Period (SP)-----	35
6.4 Evaluating Channel Access Schemes -----	36
Chapter Seven: Conclusion -----	41
References-----	42

Chapter One

Introduction

IEEE has introduced a new standard for wireless network. There is a continuous process of upgradation of IEEE802.11 to address the growing needs of vast market. With that pace, IEEE802.11ad is another significant innovation that came through continuous research on wireless networks. The standard is known as IEEE802.11ad, commercially WiGig. The technology behind WiGig is identified as the next step for the wireless mobile network. Wireless Gigabit Alliance (WiGig) and the Wi-Fi Alliance took the initiative to provide multi-gigabit per second speed in the 60 GHz unlicensed band. These organizations introduced the WLAN IEEE 802.11ad amendment [1][2] with a very high throughput of up to 7Gbps for short-range communication for wireless local area networks.

Wi-Fi adopted single 2.4 GHz band for data transmission and reception. Though the speed was not so fast, it was compatible with all wireless devices in home and business yards. In this way, dual-band Wi-Fi arrived and with the addition of 5 GHz band, online video streaming will be more enjoyable. Furthermore, due to the proliferation of data hungry solutions, and devices, existing wireless local area network technologies are facing huge

congestion and overload problem which leads operators and telecom vendors to rethink about available radio spectrum between 30 GHz and 300 GHz so called millimeter wave band to face future data propagation constraints. Wireless communication in these bands provides higher efficiency since tri-band can be developed. Tri band Wi-Fi is strengthening the efficiency of data draining solution by providing speed according to requirements of particular online service. In fact, the tri band is establishing two 5 GHz connection and one 2.4 GHz connection at a time [3]. Thus, reduction in congestion might be observed as dependability on wireless devices and connecting more devices are growing faster. Moreover, propagation characteristics of this band are different thus MAC and PHY layer design will differ from existing technologies. There is some trade-off using 60GHz, it has high free space attenuation due to oxygen in atmosphere. And signal has greater loss due to material, woods [4]. WiGig standardization started in 2008 and draft of WiGig 1.0 standard released. In 2012, IEEE 802.11ad amendment to IEEE 802.11 defines the proper specifications.

The WiGig is comprised of hybrid Medium Access Control (MAC) protocol combining both CSMA/CA and TDMA approach. Therefore, the concern is which channel has more packet generating capacity while communicating in wireless network. And there is also a concern of performance evaluation channel access scheme among research groups. To get a clear view this study starts with related work of WLAN in second chapter, third chapter contains IEEE 802.11 Standard's basics, fourth chapter is about mmWave basics, fifth chapter is about IEEE 802.11ad, ns-3 implementation and analysis has shown in chapter six, chapter seven concludes with some future work proposal.

Chapter Two

Related Work

From the beginning of wireless connectivity, researchers, protocol developers are working to develop and invent edge technology to meet the respective demand according to time. WLAN introduces internet access in wireless using Wif.

IEEE 802.11 working group led to the task group 'S', later on it was 802.11s which implements Wireless Mesh Network amendment. It supports any level protocol due to better broadcast domain [5].

IEEE 802.11n amendment encountered a lot of problems to establish WLAN for next generation devices. However, depending on physical layer data rates up to 600Mbps, IEEE 802.11n amendment finally got standardization with throughput above 200Mbps. The technique deployed multiple transmit and receiver antennas named MIMO [6]. There are different version of WLAN standardization by IEEE. But there is definitely some different task regarding IEEE 802.11ad. In 5G, there will be everything connected with each other for example, smart home, smart city, parking stations etcetera.

Advanced metering infrastructure (AMI) is considered as the core component in smart grid [7]. The information centric networking (ICN) is a promising architecture for the

future internet communication. But there is a need for accumulation with 5G, thus AMI is also includes 5G wireless communication. At present dedicated physical resources are used for content delivery which is increasing complexity. The idea is to use abstract of physical layers. Wireless network, specifically there is huge possibility of including AMI as the component of smart grid in coming GHz speed communication.

Integration of WiFi and cellular network implemented years ago. But there is a task of taking roaming decision for a user and access point selection mechanism 3GPP TS24.312 and IEEE 802.11u, k standards [8]. So, in 5G there will be demand of taking roaming decision and access point selection.

There is need for ICN integration in WLAN, so IEEE 802.11ad can be in the main row. Power efficiency is the buzz word of technological world. An optimal power consuming green model of ICN [9] can be defined considering the 5G router.

However, the discussion on future related works can be realized in a small scale. Because, no one particularly knows the vastness of technology innovation. Network Function Virtualization, Software Defined Network, Information Centric Network require to address through the next generation WLAN standard.

Chapter Three

IEEE 802.11 Standard

This chapter provides prior discussion on IEEE 802.11 standard to make further complex and hybrid Medium Access Control and Physical Layer understandable.

Medium Access Control (MAC) and Physical Layer (PHY) compatible device which satisfies IEEE 802.11 requirement called station (STA). Access Point (AP), is extended capabilities STA, acts as central device for the other STA of a WLAN. To get access to the networks, STAs must have to authenticate and associate with an AP firstly. Thus, STAs and APs form topology called Basic Service Set (BSS), basic building block of IEEE802.11 architecture. As mentioned earlier, STAs depends on AP for communication, each STAs contain at least a link to AP for get connected with BSS. Here the link, in fact addressed from MAC layer. Link enables two STAs to exchange MAC Service Data Units (MSDUs), and every successfully received MSDU is acknowledged in 802.11. Acknowledgment (ACK) is short frame and sent using Modulation and Coding Scheme (MCS).

All STAs in wireless single-hop-network send and receive frames via the AP. Here, AP operates like relay between STAs. Extended Service Set (ESS) is formed with the help of Distribution Service (DS) which interconnect BSSs through connecting multiple APs. So AP

relies on Distribution System Medium (DSM) to provide the DSS. 802.11 provides up to four address field to the AP. Firstly, MAC address of the STA under the source address which generates a frame. Secondly, Destination Address (DA) field contains the receiver's address. Thirdly, Transmitter Address (TA) holds own MAC address at the time of forwarding frame from AP. Finally, to identify the next intended receiver in the ESS, AP uses the Receiver Address (RA) field.

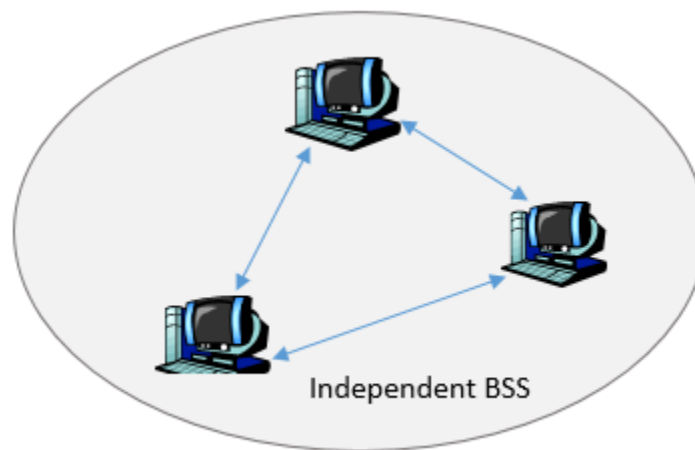

Figure 3.1: Sketch of an Ad Hoc Network

From the above paragraphs it is to say, a group of STAs that are under the direct control of single coordination function is called BSS. And BSS has areas like cell concept of cellular communications which is geographical area, named as Basic Service Area (BSA). Alike cellular communication, all STAs in a BSS can communicate with other STAs in a BSS. However, interference from nearby BSS, multipath fading cause transmission medium degradation. As a result, this can cause appearing STA as hidden STA. Formal ad hoc network of IEEE 802.11 is illustrated in IBSS. From the figure 3.1, any STA can establish direct-communications session with any STAs in the BSS. Apart from ad hoc network,

infrastructure networks are implemented to provide users specific services and range extension in wireless. At the beginning of this chapter, it is described that APs are the key to develop such infrastructure networks. AP is kind of base station in cellular communication.

There are integration points between multiple BSSs which requires for range extension by AP. Previously mentioned, DS is backbone network which is responsible for MAC-level transport of MAC service data units (MSDUs). Physically DS and BSS have the alike transmission medium, but logically there is no resemblance among DS and BSS. DS is completely used as transport backbone to transfer packets between different BSSs in the ESS.

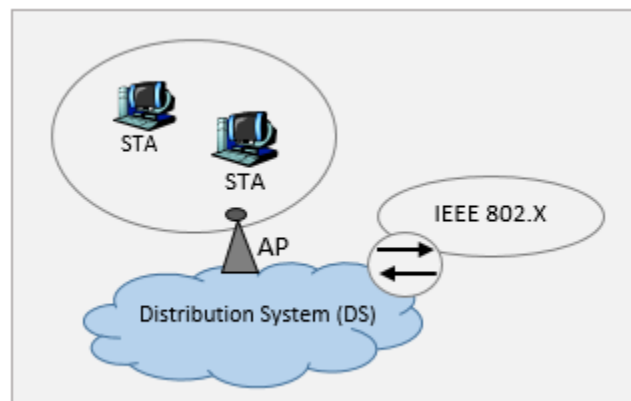

Figure 3.2: Infrastructure Network

Wireless user can get access into wired internet via a device known as portal [10], a logical entity. Portal specifies integration point where the IEEE 802.11 network adds up with a non IEEE 802.11 network. In figure 3.2, assume the network is IEEE 802.X, the portal

includes analogous functions. Portal allows to range extension and different frame format translation.

3.1 Physical Layer

Frequency hopping spread spectrum (FHSS), direct sequence spread spectrum (DSSS), IR are physical layer implementation specification [11]. Among these three, FHSS is ISM band that utilizes 2.4 GHz. There are number of channels which has different hopping sequences enabling multiple BSSs to coexist in the same BSA. This may become important to alleviate congestion. In fact, how the data will be sent over air at what data rates, basically determined by physical layer modulation formats and coding rates. Aforementioned, DSSS is appropriate for older compatibility in the early 802.11 standards. With the ages, Orthogonal Frequency Division Multiplexing (OFDM) is being very popular standards recent days, since newer methods are more efficient having higher data rates. Spread spectrum used barker sequence to spread data symbol. IR band operates with non-directed transmissions and it is designed for indoor use only. IR is designed to receive LOS and reflected transmissions.

3.1.1 Direct Sequence Spread Spectrum (DSSS)

At the starting period, 802.11 standard uses DSSS modulation. Spread name in a sense that carrier signal occur over the full spectrum of transmitting frequency. DSSS multiply the transmitted data with noise signal of +1 and -1 pseudorandom sequence. Eventually it higher than message signal. At the receiver end, message signal is reconstructed by de-spreading process. Mathematically, correlation between transmitted PN sequence and

assumed PN sequence of receiver [12]. There is a drawback of this mathematics. De spreading process results in no gain for signal while a transmitter randomly transmits on the same channel with a different PN or no PN. This drawback is the basis of code division multiple access (CDMA). Here multiple transmitter share the same channel but with limit of cross correlation properties of PN sequences.

3.1.2 Orthogonal Frequency Division Multiplexing (OFDM)

OFDM technique is effective to face adverse effects of multipath propagation and inter-symbol interference (ISI). OFDM enables to encode data on multi sub carrier, and transmission of data with high rate by dividing the data into parallel bit streams. Channel quality may improve due to its several modulation and coding techniques. In the past, there was a problem of spectral overlapping. The sub-carriers are orthogonal to each other. As a result, sub-carriers conserves BW, even though there is overlap, it conserves BW [12]. Equally distributed high rate data across the sub carriers reduces data rate and symbol duration for the sub carrier increases. Thus dispersion and multi-path delay spread get reduced.

OFDM also suffers from loss due to noise and distortion resulting inter-carrier interference (ICI). The advantage of OFDM over single carrier is the ability to overcome frequency selective fading due to multipath without channel equalization filters. Channel equalization is not complex since OFDM is viewed as slow modulation narrowband signal rather than rapidly modulated wideband signal. Low symbol rate allows to use guard

interval. Thus ISI is eliminated and diversity gain is attained by using time spreading, thus SNR is improved.

3.1.2 Data Modulation and Coding Combinations

Data transmission over unreliable and noisy communication channels is challenging. Forward Error Correction (FEC) is useful scheme for data transmission over challenging channels. The task of FEC is error correction after detecting the error without retransmission [12]. Sender sends redundant error correcting code along the data. Receiver examines upon the redundant bits and removes the redundant bits before passing message when data is free from errors. Chip is pulse of DSSS code. The number of pulses per second at which the code is transmitted is the chip rate.

Modulation and Coding Scheme (MCS): PHY layer parameters. There are several modulation order like DBPSK, DQPSK, BPSK, QPSK, 16-QAM, 64-QAM, 128-QAM, 256-QAM. There is FEC rate like $1/2$, $2/3$, $3/4$, $5/6$ [12].

3.2 MEDIUM ACCESS CONTROL

Key functionality of MAC sublayer is channel allocation, protocol data unit (PDU) addressing, frame formatting, authentication, de-authentication, integration, fragmentation and reassembly [13]. Contention mode is available in transmission media, each STA has to contend for access to the channel for data transmission. So there is both contention period and contention free period. In this case, different frames perform different essential task. Management frames perform probe request and response, and

beacon. Management frame also ensure authentication that enables STAs to exchange frames. Station association, disassociation with the AP, timing and synchronization, and authentication tasks are carried by management frames. Functionality of control frames are – request to send (RTS), clear to send (CTS), for positive acknowledgments during the CP, and to end the CFP. Data frame has the frame control bits like “to DS” and “from DS” enabling both false. Later on, “to DS” and “from DS” frame control bits are set true [11].

From the above paragraphs, contention based and contention free period has been driven to discuss Carrier Sense Multiple Access (CSMA). MAC protocol basically the connector between upper networking layers and physical layers. The IEEE 802.11 MAC confirms fair channel access and link management with various functionality. WLAN usually uses half duplex at the time of transmitting and receiving on the same channel. Same channel communication generates interference when multiple devices tries to get access the channel at the same time. MAC solves these problems by having device contention. At idle period MAC listens to observe whether any other STAs are starting communication. The device get chance for transmission if and only if channel remains idle. The phenomena happens in duty cycle, that is active and sleep period [14]. CSMA is implemented at Distributed Coordination Function (DCF) at the core of MAC. To control collision, CSMA is used with Collision Avoidance (CSMA/CA) to fairly permit access to channel. CSMA/CD is not used because STA is not capable of listening to the channel while transmitting. STA performs a Clear Channel Assessment (CCA) before starting transmission. CCA senses DCF Interframe Space (DIFS) duration using Physical Carrier Sense (PCS) and Virtual Carrier Sense (VCS). VCS is performed by the STAs by sending MAC

Protocol Data Unit (MPDU) information in the header of RTS, CTS, data frames. MPDU is passed from MAC sublayer to physical layer. MPDU contains payload and Cyclic Redundancy Checking. However, STA only start transmission when channel will remain idle. There will be a random backoff including DIFS duration, in case of busy channel. STA generates random backoff between zero and value of contention window [14].

These are the required understanding of IEEE 802.11 standard. IEEE 802.11ad has got a lot of modification according to the amendment [1]. Therefore, further functionality will be narrated in the following chapters.

Chapter Four

Fundamentals of Millimeter Wave

5G internet is going to launch commercially coming days. To keep pace with increasing demand of speed and better performance, 5G is expected to be indispensable for each wireless communication. For future WLAN communication, millimeter wave (mmWave) is considered as the key to meet demand. The next generation WLAN and Wireless Personal Area Network are looking forward mmWave considering BW. IEEE 802.11ad and 5G cellular would be in the same topology.

4.1 Spectrum Regulation Overview

Technological advancements put us on the mountain of innovation of newer technologies. Therefore, different type of devices and services are being introduced. Human interaction to the device has become wireless, as a result wireless communication gets its peak popularity. Smart devices are providing more attractive features. Applications are becoming more data consuming than before because of integration of services with cloud. Thus cloud requires continuous connectivity and synchronization with devices. As a result, network is becoming congested. The data rate needs to be improved so that every user can get the service properly. So newer spectrum is required to meet

the scenario. Therefore, solution to the next generation problem is to use of unlicensed gigahertz spectrum for wireless communication. There are services like voice service, data service, texting service, video streaming, and applications like– smart city, smart home, medical healthcare, hospitality, manufacturing, agriculture, military, retail, transportation and automotive etcetera. To meet these user requirement, 60 GHz unlicensed band is inevitable.

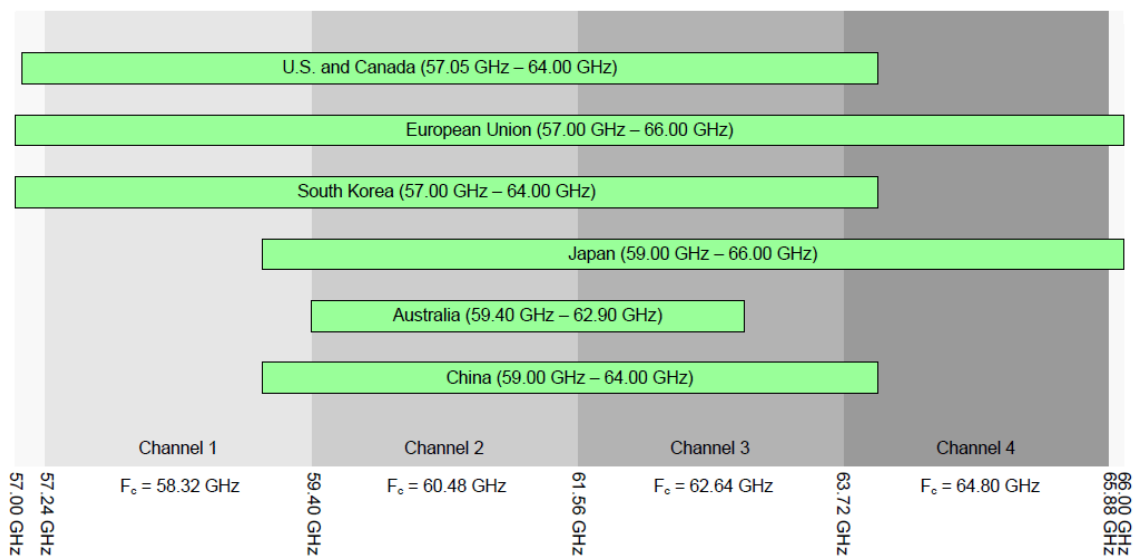

Figure 4.1: Region Based 60 GHz Frequency Allocation (Adopted from [15])

In the early 90s, US Federal Communications Commission (FCC) initialized 60 GHz frequency band. The assertion was to cover 59 GHz to 64 GHz of frequencies. The procedure was alike 2.4 GHz, 5 GHz industrial, scientific, and medical (ISM) bands. The 60 GHz frequency increases the channel capacity. International Telecommunications Union (ITU) recommends 55.8 to 66 GHz band for unlicensed use. The standardization from ITU carries substantial importance as an agency of United Nations. European Union countries

have spectrum from 57 to 66 GHz. European Conference of Postal and Telecommunications Administrations (CEPT) affiliated committee designed the spectrum to efficient use of band [16].

From the figure 4.1 [15] each of four channels is 2.16 GHz wide. Channel 2 is default for devices operating in 60 GHz spectrum. From the figure, it is also found that USA and Canada has range 57.05 GHz to 64.00 GHz. European Union South Korea, Japan, Australia, China allocates the range in between 57 to 66 GHz, 57 to 64 GHz, 57 to 66 GHz, 59.40 to 62.90 GHz, 59 to 64 GHz respectively.

4.2 Millimeter Wave Propagation

60 GHz millimeter wave propagation is described as Line of Sight (LOS), that is it will be very effective in short range communication. Therefore, it has been showing huge propagation sensitivity. The problem of having small wavelength is signal fading, shadowing and scattering since atmospheric particle may cause harm to the propagation. IEEE 802.11ad works at 57 to 66 GHz. So there will be huge loss which is a challenge for protocol developers. But industries are moving forward to design such devices which will work fine in these bands. Short range coverage of IEEE 802.11ad prevents from potential cyber threats. In this standard, specifically in 5G wireless networks, pricing can be fixed assuring satisfactory privacy and security of millimeter wave applications.

Diffraction allows propagation behind obstructions in signal propagation. In wireless communication, a signal can detect terminal devices moving at corner. When signal propagates, it faces a lot of obstacles. If the obstacles are comparable to the size of signal

wavelength, signal can reach the areas behind the obstacles by creating a point of source of radiation. Consequently, at 30 to 300 GHz attenuation can increase significantly [17]. Incident angle i of obstruction free received power is used to calculate diffraction losses. To understand the diffraction at edges various equations have been developed such as Knife Edge Diffraction (KED) method and Uniform Geometrical Theory of Diffraction (UTD). In reality, there is a lot of type obstacles such as geometrical shape inside indoor like- screens, edges of bookshelves, tables, doors, or person even pets. KED provide an approximation formula for the edge diffraction relying on perfect conductivity [17]. The equation:

$$\frac{E_d(KED)}{E_r} = \left(\frac{1+n}{2} \right) \cdot Fr(g)$$

Here, $E_d(KED)$ is diffracted electric field, E_r is electric field received from an isotropic radiator, and Fr is the Fresnel integral and g is the geometrical parameter. Estimating the signal attenuation caused by diffraction precisely is quite difficult but theoretical approximation process through KED gives better insight into the order of magnitude of diffraction loss [18].

From the analysis of comparison of angular dependent diffraction measurements and UTD modeling [17], the findings tell that addition of 20 dB attenuation for metal edge because of small change of $\Delta i = 15^\circ$ in comparison with the LOS path. For $i > 0$, interference between the LOS path and diffracted field leads to the oscillation in attenuation function. In the lit region ($i > 0$), the oscillations observed in the

attenuation function are mainly due to interference between the LOS path and the diffracted field [16]. The experimentation leads us to tell that, millimeter wave communication must rely on reflections, scattering as well as beam scattering techniques to prevent NLOS situation rather than depending on diffraction propagation mechanism. There is a term called Fresnel zones in wireless communication. Due to small wavelengths Fresnel zone is negligible in millimeter wave [17].

Information from previous paragraph, scattering has been an important propagation mechanism for millimeter wave. The reason is wavelength of the signal much smaller than most objects like- pets, persons, table, cars etcetera. So it can be denoted that scatterer created path is stronger and efficient than reflected path for the utilization of millimeter wave. Therefore, there is necessity of measuring scattering of different physical objects. Physical objects emits intercepted electromagnetic waves which can be estimated using Radar Cross Section (RCS) method. Object may vary in different shapes. And RCS values vary according to the roughness and skewness of objects for property of scattering, not necessarily upon the vastness of object [18].

The RCS of scattering is defined as the ratio power density of the signal scattered at the direction of receiver to power density of incident signal on scattering object. Therefore, bistatic radar equation:

$$RCS = \lim_{D \rightarrow \infty} \left(\frac{4\pi D^2 P d_s}{P d_i} \right)$$

Here, D is distance between receiver and scatterer, Pd_s is the scatterer power density, Pd_i is incident power density. Multiplying scattered field with RCS provides receiver power [18].

There will be significant path loss from transmitter to receiver. According to Friis equation:

$$P_r = \frac{P_t G_t G_r \lambda^2}{4\pi R^2}$$

The above equation [19] helps to compute receiver power P_r . The effective isotropic radiated power $EIRP = P_t G_t$ where P_t is transmitting antenna power, G_t is transmitting antenna gain, and G_r is receiver antenna gain, λ is wavelength, and R is distance between transmitter and receiver. Because of shorter wavelength, the loss in WiGig is about 21 to 20 dB than 2.4 and 5GHz bands. The loss can be minimized by reducing path range. But total loss cannot be eliminated by reducing range. Therefore, the remaining loss must be adjusted increasing antenna gain.

Millimeter waves face polarization, losses because of surrounding objects. The reason, as mentioned earlier, is sometimes small objects treated as larger than the wavelength. The reflective properties of different materials have shown in a list [4] rough materials scattered strongly than smooth material. Change of terminal device, reflective path change may have impact on NLOS paths. Beamforming, which reinforce the waves in a particular direction, is essential for millimeter wave propagation.

Chapter Five

Directional Multigigabit – IEEE 802.11ad

IEEE 802.11 standard along with specific modification and addition in MAC and PHY has made up IEEE 802.11ad by operating 60 GHz band. IEEE 802.11ad amendment to the IEEE 802.11 is enabled to provide multi-gigabit throughput in wireless communication. Directional-multi-gigabit, IEEE 802.11ad, and 60 GHz are used interchangeably to refer IEEE 802.11ad amendment [1].

IEEE 802.15.3c and ECMA-387 was developed to achieve very high throughput (VHT) in short range communication. But IEEE 802.11ad is specialized based on actual IEEE 802.11 ecosystem. 60 GHz differs from other VHT standards in terms of fast session transfer between IEEE 802.11. Different types of video streaming platform are getting popularity for their attractive contents. Audience wishes to enjoy HD video streaming. For this purpose, Wi-Fi launched Wi-Fi CERTIFIED Miracast™ [20].

It is mentioned in the previous chapter that there is huge path loss in between end to end communication. And just to recap, it is asserted that scatterer and reflective path is better mechanism for DMG standard. There is another assertion that beamforming technique defined by the IEEE 802.11ad amendment [1] to the 802.11 standard can act to

compensate the path loss. The directional communication scheme is intended to drag down increased attenuation in DMG [21]. That is DMG uses highly directional transmission that increase throughput and spatial reuse. In this chapter, PHY specification will be discussed first because it holds some important concept for MAC. Therefore, following sections is starting from PHY specifications of IEEE 802.11ad.

5.1 DMG PHY Layer

IEEE 802.11ad-2012 amendment to IEEE standard 802.11™-2012 has a clause specifying the required modulation to get robust and very high throughput (VHT) [2]. The reason behind specification is newer application compatible to DMG capability have different problems to different devices. So IEEE 802.11ad defines four different types of PHY layers supporting a set Modulation and Coding Schemes (MCS). Thus, understanding the design requirement industry can go for production.

Among the four different types of PHY layer, DMG control PHY is mandatory to implement for transmission and reception of PPDU. Control PHY has MCS0 which operates to low SNR with 27.5 Mbps throughput [22]. This portion is used for Beamforming (BF).

DMG OFDM PHY - MCS 13-24 has data rates of 6.76 Gbps. Orthogonal Frequency Division Multiplexing provides best service in multipath environments [2]. However, this layer will be obsolete in the next IEEE 802.11ad draft.

Single Carrier (SC) PHY defines MCS 1-4 modes among MCS 1-12 as mandatory to all devices for interoperability. OFDM PHY is complex and targets less stringent power

devices [2]. So, SC PHY will be implemented in power efficient and lower complexity devices such as - mobile phones and tablet devices.

Low Power (LP)-SC PHY, similar to the SC PHY layer with MCS 25-31 mode. This mode is used for additional power reduction. This modes will use low-density parity check (LDPC) code [16]. This layer is energy efficient for battery-operated devices. However, this layer is optional, and may be removed from next draft alike OFDM PHY.

5.1.1 DMG PHY Frame Structure

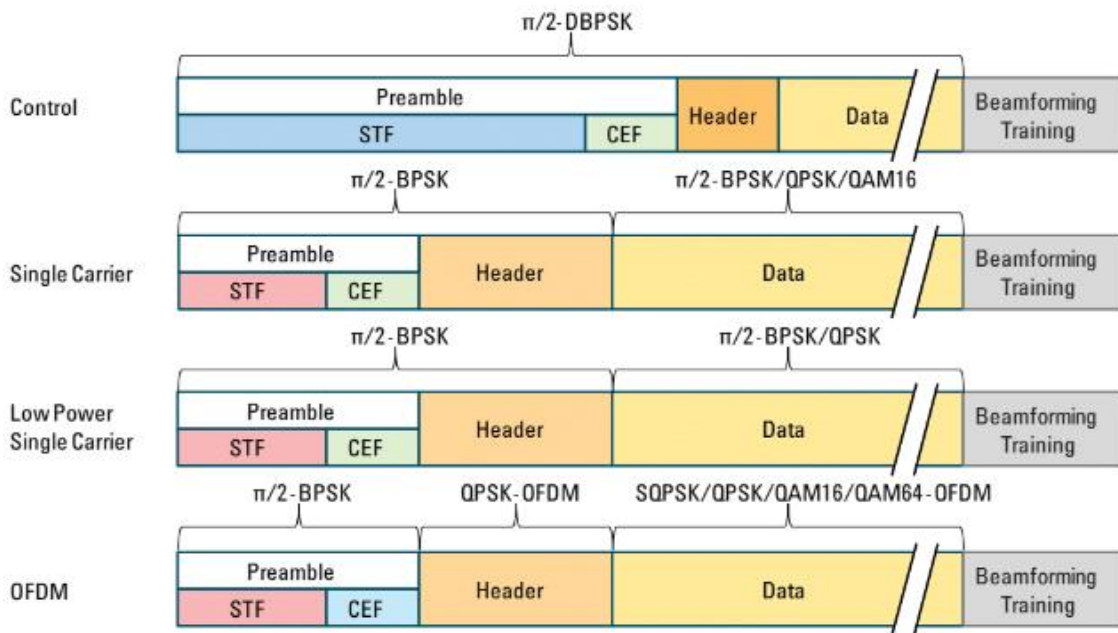

Figure 5.1: Four PHY layer Frame Structure (Adopted from [20])

From figure 5.1 [20] frame structure for four types of PHY layer is showing that except control PHY frame rest of the three frames are designed for simple receiver processing. Each PHY layer is showing required modulation and coding schemes (MCS). Later of this chapter MCS is described. From OFDM PHY frame structure, it is seen that presence of

higher constellation modulation can provide better spectral efficiency. On the contrary control PHY require robustness, thus differential binary phase shift keying (DBPSK) is used.

The preamble is the starting of the frame which consists of short training field (STF) used for detecting the type of the PHY layer and channel estimation field (CEF) used for channel estimation [22]. The STF appends the automatic gain control (AGC), and provides time and frequency synchronization. Golary sequence is used to generate the preamble of frame which is $\pi/2$ -BPSK [20]. But for control PHY $\pi/2$ -DBPSK is used for robustness.

These fields are followed by header which includes information of the content of the packet such as payload length and index of the MCS used. Header field is also differs in control PHY significantly than other three PHY layer. From the figure 5.1 header modulation technique is $\pi/2$ -BPSK and quadrature phase shift keying (QPSK), and control PHY is $\pi/2$ -DBPSK. Finally, WiGig appends the AGC and Beamforming (BF) Training (TRN) field for beam tracking [1]. The header together with MAC header and MAC payload are secured by cyclic redundancy checking (CRC).

5.1.1.1 Preamble

The aforementioned STF and CEF fields are generated using $\pi/2$ -BPSK modulated iterating Golary sequences. The process is described below with necessary figures.

Golary sequences are sequences of bipolar (± 1) with specific autocorrelation property. Let, two sequences Ga_{128} and Gb_{128} where the symbols ' a ' and ' b ' indicate sequences from complementary pair. The suffix symbolizes the length of the sequences. Theory and

mathematics is available in materials. But some important characteristics have been written instead of providing mathematical proof of Golary Sequence generation. Firstly, low false peaks and low DC content is found in $\pi/2$ rotation [16]. Secondly, autocorrelations can be performed parallely using fast correlator.

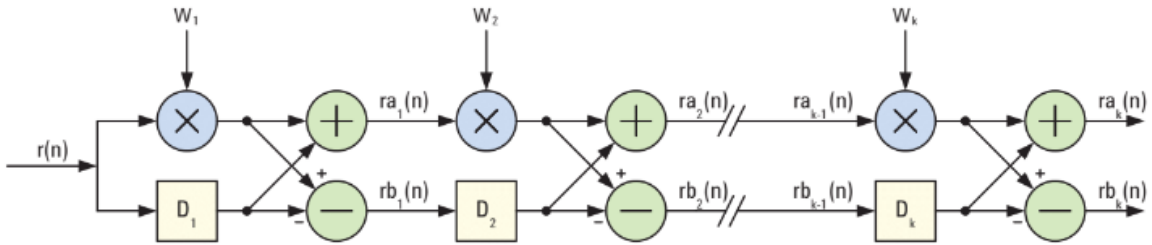

Figure 5.2: Fast Correlator (Adopted from [20] figure 4)

It is seen from figure 5.2 correlator that it performs correlations between 'a' and 'b' parallely. It has one input $r(n)$ and two output sequence $ra_k(n)$ and $rb_k(n)$. For Ga_{128}/Gb_{128} version, the input is STF of control PHY, then output $rb_7(n)$ and $ra_7(n)$ would produce positive correlation spikes for SC PHY or OFDM PHY and control PHY respectively [20]. Therefore, receiver will detect the frame structure according to the different STF sequences. Furthermore, spikes amplitude can be used for AGC, and spike frequency gives the reference sample rate. To signal the end of the STF negative correlation spike is generated at the output.

CEF computation use complementary property, from the figure 5.3 that first four and second four Ga_{128}/Gb_{128} sequences are grouped into 512 symbol i.e Gu_{512} and Gv_{512} . Gu_{512} and Gv_{512} blocks help to calculate two independent channel estimations. The basic channel estimation field calculation is illustrated in Figure 5.4 [20].

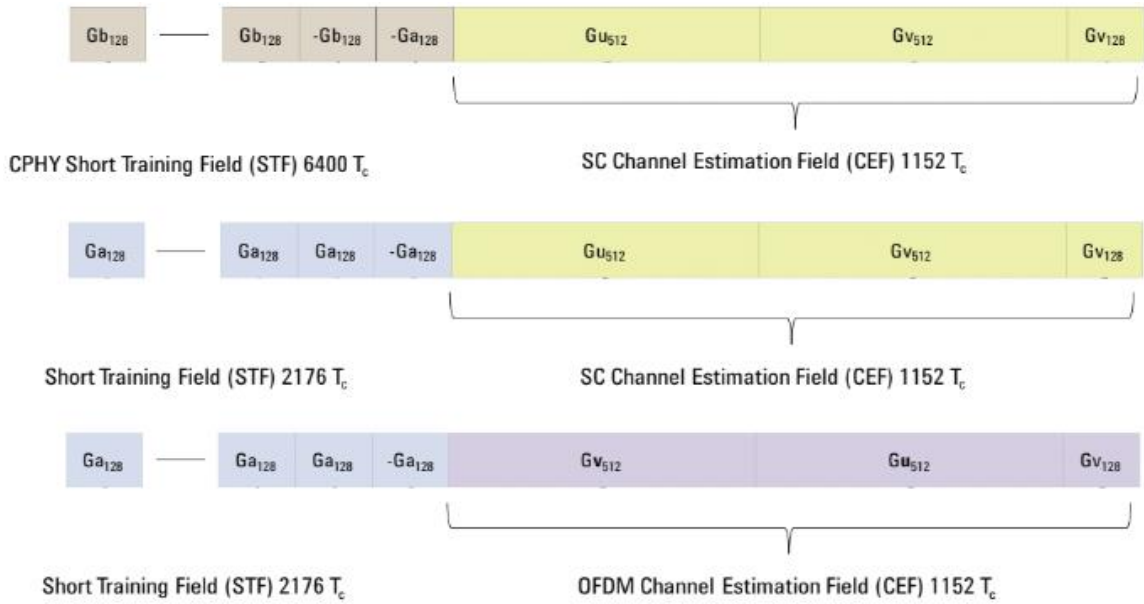

Figure 5.3: Preamble Showing CEF Structure (Adopted from [20] figure 7)

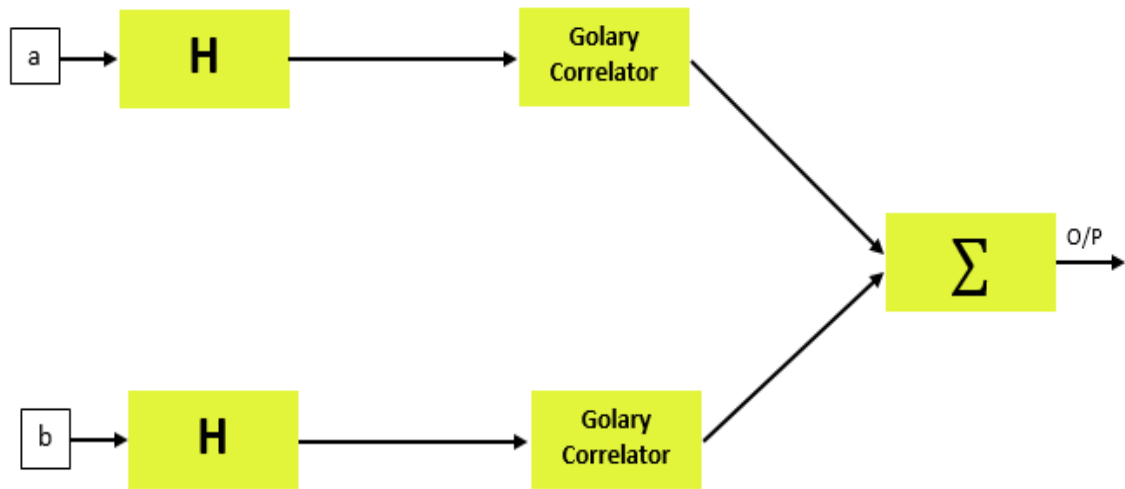

Figure 5.4: Block Diagram of Channel Estimation Field

Here output would be,

$$\begin{aligned}
 &R(a) + R(b) \\
 &= a * a * h(t) + b * b * h(t) \\
 &= (a * a + b * b) * h(t)
 \end{aligned}$$

$$= \delta(t) * h(t)$$

$$= h(t)$$

If we pass two time sequences 'a' and 'b' through the channel H, there will be a convolution between two time sequences and channel impulse response $h(t)$. When these convoluted signals pass through the Golary correlator for known input sequence, then the autocorrelation of the sequences will produce the impulse response $\delta(t)$. Therefore sum of channel impulse response $h(t)$ and $\delta(t)$ results only channel response $h(t)$.

5.1.1.2 Header

Header carries information about payload length in bytes and index of MCS used which indicates that which MCS being used for Modulation and Coding Scheme in payload.

The header field structures contains some of the more important fields are [20]-

- ▶ Scrambler Initialize: Seeding the scrambler which is used for data whitening purposes.
- ▶ MCS: Indicating the modulation and coding scheme used in payload part.
- ▶ Length: Number octets of data in the payload.
- ▶ Training Length: Length of operational BF training (BFT) at the end of packet.
- ▶ Packet Type: Whether the optional BFT field is set up for transmitter or receiver training.
- ▶ HCS: CRC-32 checksum over the header bits, includes MAC payload and MAC header.

5.2 Medium Access Control

According to IEEE 802.11ad amendments, there has been different usage case which lead shifting from WLAN idea of servicing larger area to Wireless personal area network [23]. Therefore, core functionality of IEEE 802.11 standard MAC has been modified significantly in order to adjusting the wireless communication in 60 GHz.

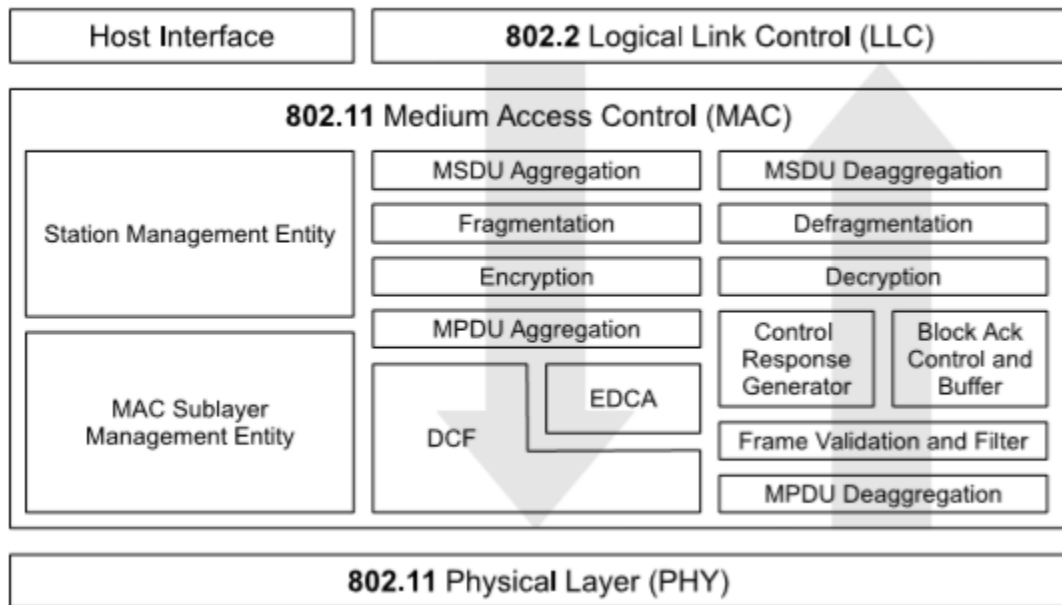

Figure 5.5: Internal 802.11 MAC Architecture (Adopted from figure [11])

Figure 5.5 [11] shows architecture of 802.11ad MAC. Contention based access happens in Contention Based Access Period (CBAP). CBAP uses enhanced distributed channel access (EDCA) queues. There is also contention free access method named Service Period (SP). Starting of each beacon interval composed of three periods- firstly, the Beacon Transmission Interval (BTI), secondly the Association Beamforming Training (A-BFT), and thirdly, the Announcement Transmission Interval (ATI). These periods have direct access to PHY while maintaining CSMA/CA in CBAP.

Distributed Coordination Function (DCF), discussed in chapter three, cannot provide service to directional multi-gigabit (DMG) PHY. Fundamental concept of DCF is to listen to the channel and wait if the channel is busy. Depending on this classic process does not work out properly due to high directional links and path loss, higher attenuation. Personal Basic Service Set (PBSS) instead of BSS is defined by IEEE 802.11ad amendment to allow STAs to communicate in ad-hoc manner [1].

Personal service set Control Point (PCP) or access point (AP) grants the DMG access in PBSS. PCP with complete set of IEEE 802.11ad capabilities and services among all STAs is selected in an ad hoc network [1]. IEEE 802.11ad has a major difference between conventional MAC and DMG MAC. DMG Channel Access is introduced in the amendment instead of DCF. In spite of that, DCF is still found during CBAP for DMG channel access scheme. In amendment, DMG communication sketched a hybrid MAC approach to meet various cases. So, IEEE 802.11ad has contention based access, scheduled channel time that is based on TDMA which is also used in and dynamic channel time allocation which is polling mechanism.

In conventional WLAN, AP access the medium through periodic Beacon Intervals (BI). Beacon signal indicates the existence of WLAN network where BI is limited to 1000 ms [24]. IEEE 802.11ad manages access to medium in the similar fashion with BI. Each beacon is divided in different access periods discussed in previously of this book. Figure 5.6 illustrates BI composed of Beacon Header Interval (BHI) and Data Transmission Interval (DTI). The BHI composes BTI, A-BFT and ATI and DTI composes CBAP1, SP1, CBAP2, SP2 described below [22]-

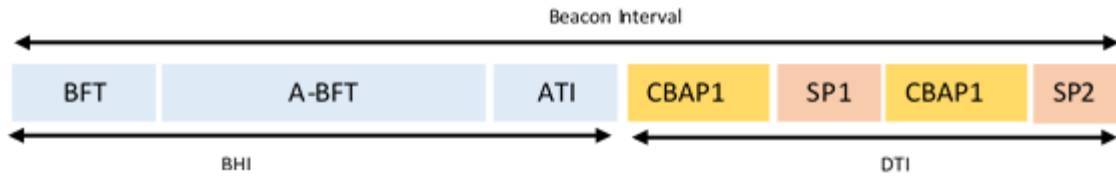

Figure 5.6: Beacon Interval

Beacon Transmission Interval (BTI) transmits multiple DMG Beacon from different antenna sector across DMG PCP/AP to declare the network existence. Only PCP STAs in a PBSS will transmit during BTI.

- ▶ Association Beamforming Training (A-BFT) is used by DMG STA to train antenna system to communicate in contention based manner with the DMG PCP/AP.
- ▶ PCP/AP uses announcement transmission interval (ATI) sub-interval to exchange management frames with beam trained STAs.
- ▶ CBAP is used to access the channel using Enhanced Distributed Coordination Function (EDCF) which is provided in Hybrid Coordination Function (HCF) through DCF.
- ▶ In Scheduled Service Period the channel is dedicated for two DMG STAs. Therefore, DMG STA does not contend to access the channel.

IEEE 802.11ad provides physical carrier sensing discussed previously and virtual carrier sensing (VCS) mechanism. VCS uses Network Allocation Vector (NAV) which is also used in TDMA based approach in [14]. NAV counts down to 0 to indicate channel occupancy time in microseconds by another station. In IEEE 802.11 VCS used request-to-send (RTS) and clear-to-send (CTS), whereas in IEEE 802.11ad VCS mechanism uses RTS and DMG

CTS. STAs update their NAVs using Duration field [23]. Receiver STAs sets own NAV to the Duration value field in the in the MAC header of the frame. The channel is considered as busy when either PCS or VCS tells that the medium is occupied. There must have a non zero values among multiple NAVs, so that it can reply DMG RTS with DTS (denial-to-send), thus the access category gets to know that the desired medium is busy. There are four access categories (ACs)- Background (B), Best Effort (BE), Video (VI), and Voice (V) having different functionality and priority of data. If the channel is idle for a period, these ACs contend with each other to enter into the channel.

SP is defined by the Time Division Multiple Access (TDMA) for the DMG communication. Considering power efficiency issue and robustness of TDMA in wireless communication, IEEE 802.11ad implemented the functionality. This will be effective in power saver mode as well as for mobile devices [1], since idle STAs goes in hibernate mode during channel access time.

Chapter Six

ns-3 Implementation and Simulation Analysis

ns-3 is a popular open source and discrete event network simulator. It is free software, licensed under the GNU GPLv2 license [25]. It is mainly focused for research, educational and development purpose. The goal is to develop open simulation environment for modern networking research and encourage community contribution. ns-3 is chosen for satisfactory performance over any other network simulators, and it contains a lot of proper directed documentation of different built in features. This chapter explains the focus of this dissertation. The IEEE 802.11ad channel access scheme simulation is discussed in this chapter with necessary simulation output. Prior to that, network details has been discussed.

ns-3 is C++ library based and scenario specific simulators and allows code reuse and ease of integration. The entire simulation of ns-3 is designed as- Node, Application, NetDevice, and Channel [25]. The simulation with objects of various types is provided in details below [25]-

Node: A node is like a computer, which has object like applications, protocol stacks, and NetDevices. A group of nodes in wireless network with the same functionality is grouped in a specific container.

Application: It is installed in a node to source packet traffic. UDP packet transmission is maintained by application at a defined time.

NetDevice: A NetDevice provides a network interface to communicate between channel and node that implies encapsulation of PHY and MAC.

Channel: Nodes in the simulated network communicated through a channel which emulates medium. Channel also implements Friis Propagation Model.

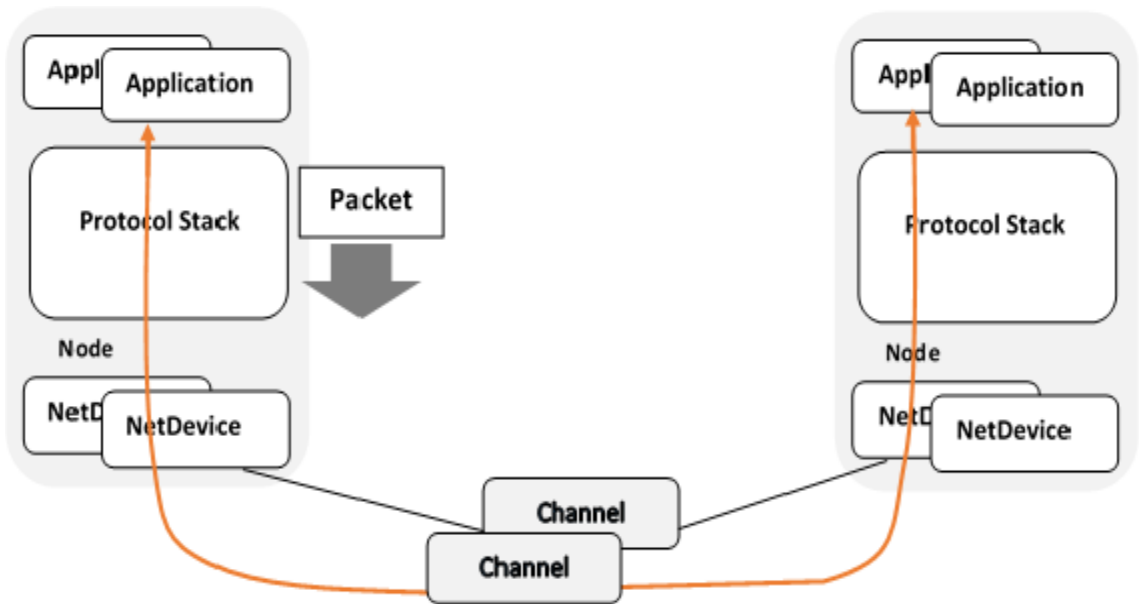

Figure 6.1: Simulation Network Architecture

From figure 6.1 a number of nodes can be connected with the channel for communication. Each node has application, network stack, NetDevice separately where application does the sourcing, addressing and routing comprises network stack, channel accessing is performed by the NetDevice.

The performance of channel access scheme of IEEE 802.11ad simulation main program involves following steps:

- ▶ Nodes in a wireless network grouped into containers.
- ▶ Nodes are added in the installed NetDevices.
- ▶ Nodes are assigned an address and routing is performed at network stack level.
- ▶ Application starts at scheduled time, and simulation is also scheduled to stop.

6.1.1 WLAN Simulation

ns-3 includes MAC and PHY implementation according to the amendments of IEEE 802.11 standard. The following figure is the design of WLAN WifiNetDevice architecture adopted from ns-3 documentation.

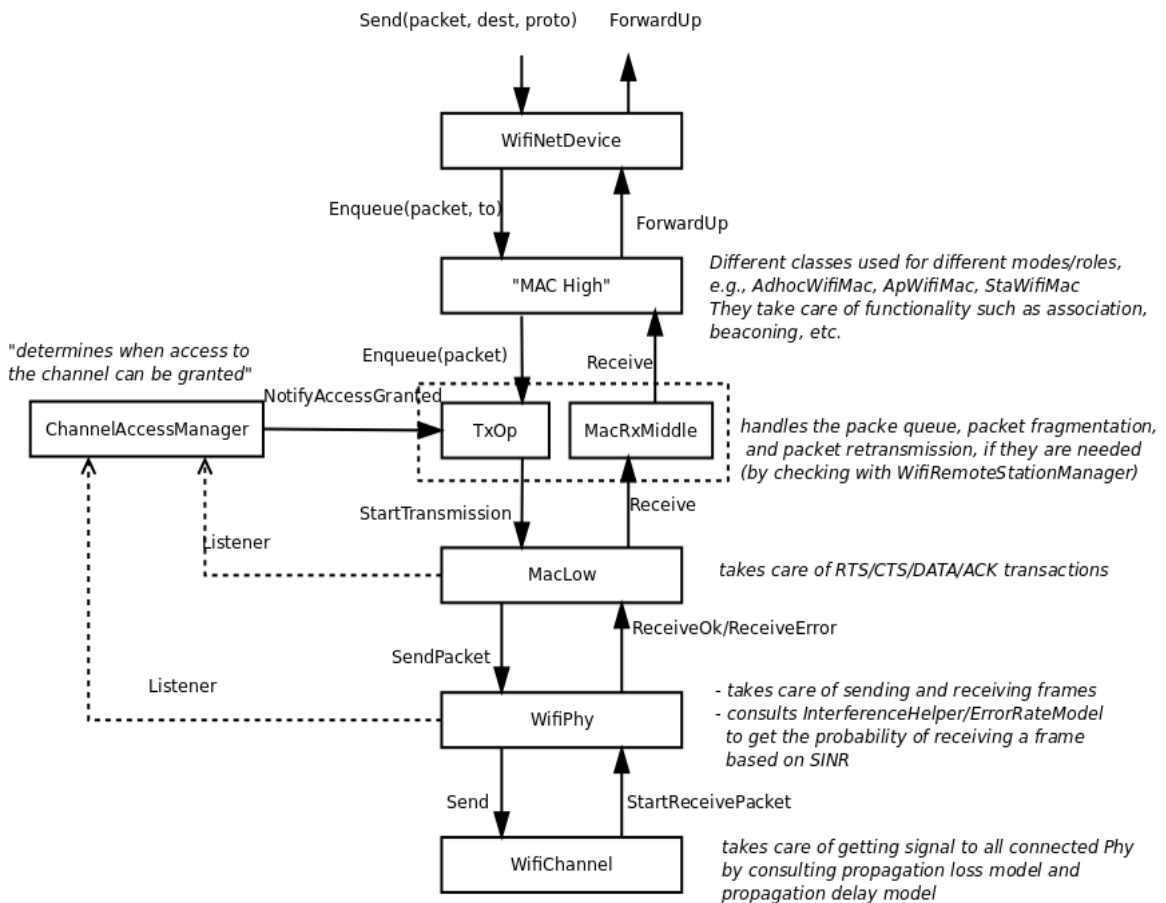

Figure 6.2: WLAN WifiNetDevice Architecture (adopted from [26])

The figure 6.2 contains specification of each block articulately. There is channel access handler named as `ChannelAccessManager` which works as channel access gateway by operating whom to access next in the medium. This model is fundamental design of `WiFiNetDevice` for WLAN of any kind. The implementation of figure 6.3 is modular approach and there is three sublayers enlisted below:

- ▶ PHY layer models
- ▶ MAC low models
- ▶ MAC high models

6.2 IEEE 802.11ad Channel Access Scheme Simulation

Prior to the proceedings, recapitulation on IEEE 802.11ad MAC is further analysed here. The current ns-3 supports IEEE 802.11 specifications proper implementation of MAC layer for IEEE 802.11 specifications. The IEEE 802.11ad is divided into four layers-

- I. MAC High Layer: Provides MAC layer management entity depending on networks like infrastructure BSS or IBSS.
- II. MAC Low Layer: This layer performs DMG RTS/CTS/ACK frames transmission using DCF and Enhanced DCF Channel Access. It also delivers MSDU and MPDU aggregation and de-aggregation capabilities.
- III. Physical Layer: Provide probabilistic error model of packet transmission and handles packet transmission and reception over the channel. It also calculates interference among different STAs.

IV. Channel Layer: The medium to connect different wireless STAs for communication. It models propagation effect in real environments.

This chapter incorporates channel access scheme of WiGig which requires some modification of current WLAN architecture.

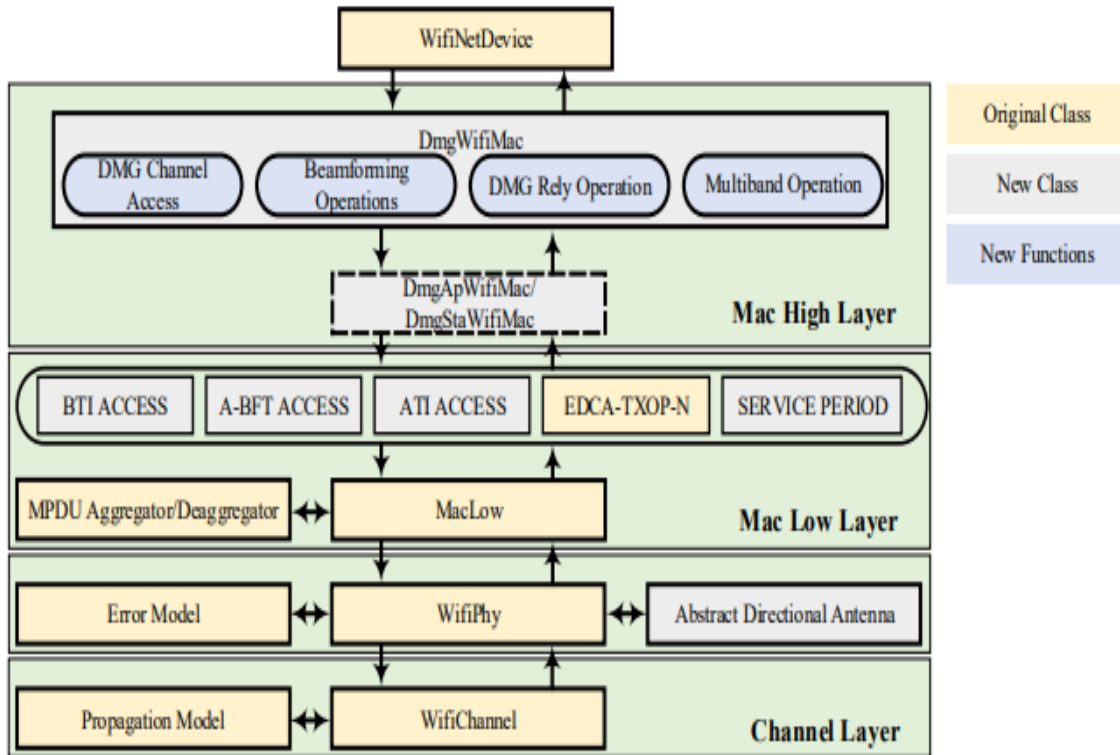

Figure 6.3: IEEE 802.11ad MAC (adopted from [22])

From the figure 6.3 [22] DmgWifiMac class provides two classes- DmgStaWifiMac and DmgApWifiMac. The main purpose of derived class is to represent different BSS. DmgStaWifiMac implements procedures specific to DMG STA. The DmgApWifiMac class permits channel access through BMG Beacon across antennas. The NAV time is announced in the duration field of MAC header. Before DMG Beacon transmission it is required to ensure whether the channel is occupied or idle.

6.3 Channel Access Schemes of IEEE 802.11ad

In this section, methods used in IEEE 802.11ad amendment to access the channel has been defined though CBAP and SP which is already mentioned in previous chapter. To make understandable with the simulation results, it is discussed below-

6.3.1 CSMA/CA

CSMA/CA provides an equal probability for all the STAs to access the wireless channel. CSMA/CA provide virtual MAC queues for each access category (AC) ensuring Quality of Service (QoS) through EDCA [27]. But CSMA/CA is not well suited in mmWave wireless networks. Since mmWave has directional transmission and reception, it forces a STA to listen to channel in a spatial direction. Consequently, STAs will mistakenly determine a busy a channel as idle channel, which will result in collision. In a distributed medium access procedure, AP does not know the direction of reception. To face this problem, quasi-omni pattern is maintained by AP to receive any frames transmitted from nearby STAs.

6.3.2 Scheduled Service Period (SP)

SP has been discussed previously. ADDTS request is sent to the PCP/AP from non PCP/non AP DMG STA. Source Association Identifier (AID) and destination AID allocation is identified by the ADDTS. An AID is unique id that differentiate a STA within BSS. MAC address of the requesting STA and allocation characters are the two parameters the trace source provides. The dynamic allocation process of IEEE 802.11ad occurs at the time of

DTI access period. Each station willing to participate in dynamic allocation through the polling of PCP/AP at Polling Period (PP) of dynamic SP allocation. STA declares wish to join the PP by setting `STA Availability` element true. The poll frame is replied by series of SP Request (SPR). PCP/AP allocates resources based on the request. The allocation is announced by the Grant Period (GP). To accomplish the task `RegisterSPRequestFunction` in the `DmgStaWifiMac` class is provided to call back. And one trace source `PPCompleted` in the `DmgApWifiMac`.

6.4 Evaluating Channel Access Schemes

In this experiment, packet throughput of UDP considering MCSs for both SC PHY layers. The topology is comprised of a DMG PCP/AP and single DMG STA which is used to get the throughput in both CBAP and SP Channel Access (SPCA). In `PacketSink` an `OnOffApplication` provides the traffic towards `PacketSinkApplication`. In this analysis, we will see how CBAP and SPCA works according to the graph. Since CBAP is contention based and SPCA is dedicated TDMA, there will be substantial difference of packet flow.

In the studied experimentation, the MAC Queue Size is 1000 Packets, PHY layer is DMG MCS12 Single Carrier PHY. The figure 6.4 and figure 6.5 is generated using CBAP and SPCA produced pcap files. Therefore, the PCAP files has been analysed in Wireshark packet analyzer. The statistics of pcap file is given in the figures below-

Wireshark IO Graphs: Station-1-0.pcap

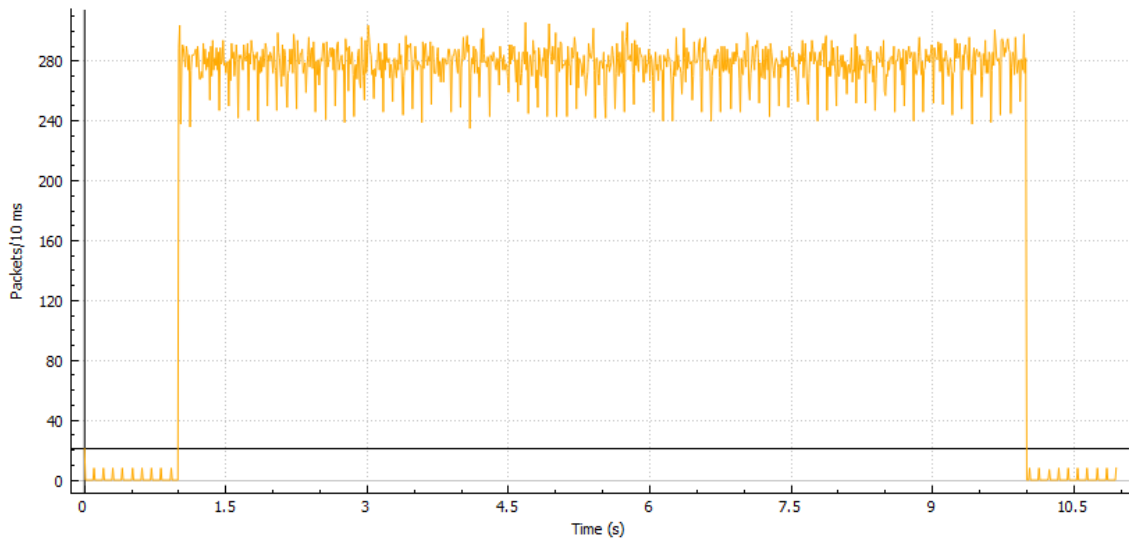

Figure 6.4: Time vs Packets/10 ms DMG STA simulation for CBAP

Wireshark IO Graphs: Station-1-0.pcap

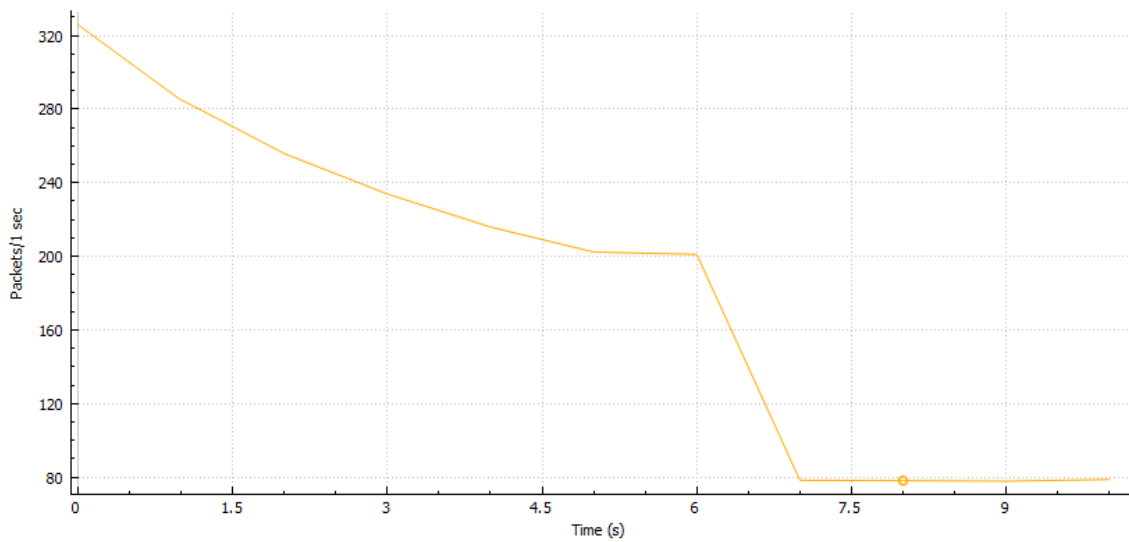

Figure 6.5: Time vs Packets/second DMG STA Simulation for SPCA

For DMG STA, these figures show that, in CBAP more packet is generated at DMG STA than SPCA. Therefore, the simulation generates a huge amount of packets in CBAP under User Datagram Protocol (UDP). On the contrary same STA in SPCA is not generating much

packet but provide very close throughput with respect to CBAP. However, SPCA is dedicated and CBAP is contention based channel access scheme. There is no packet loss found in pcap files at Wireshark packet analyzer.

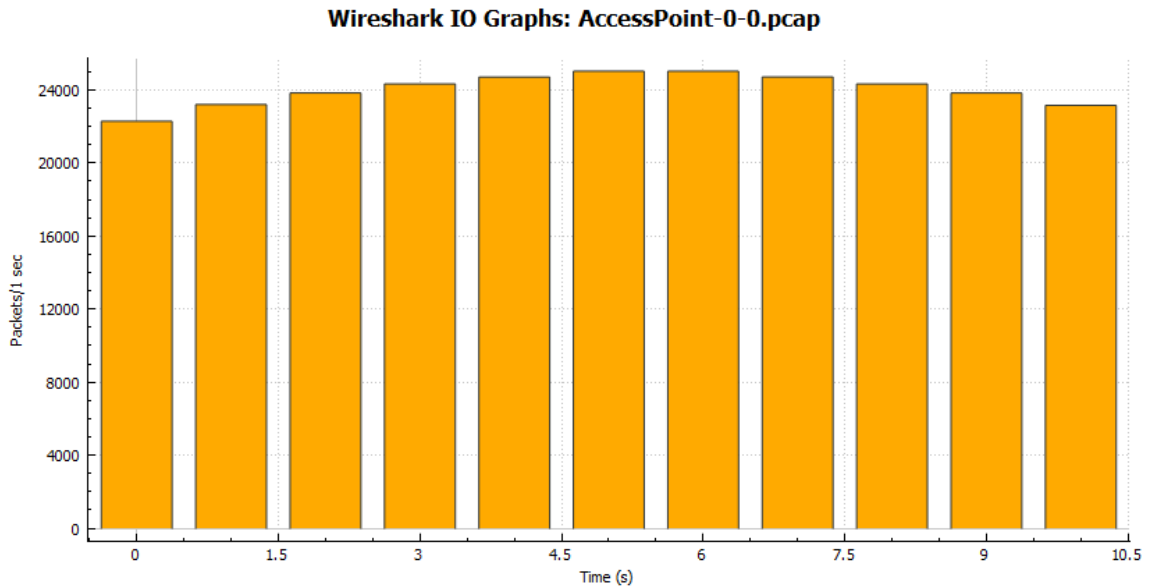

Figure 6.6: Time vs Packets/s PCP/AP simulation for CBAP

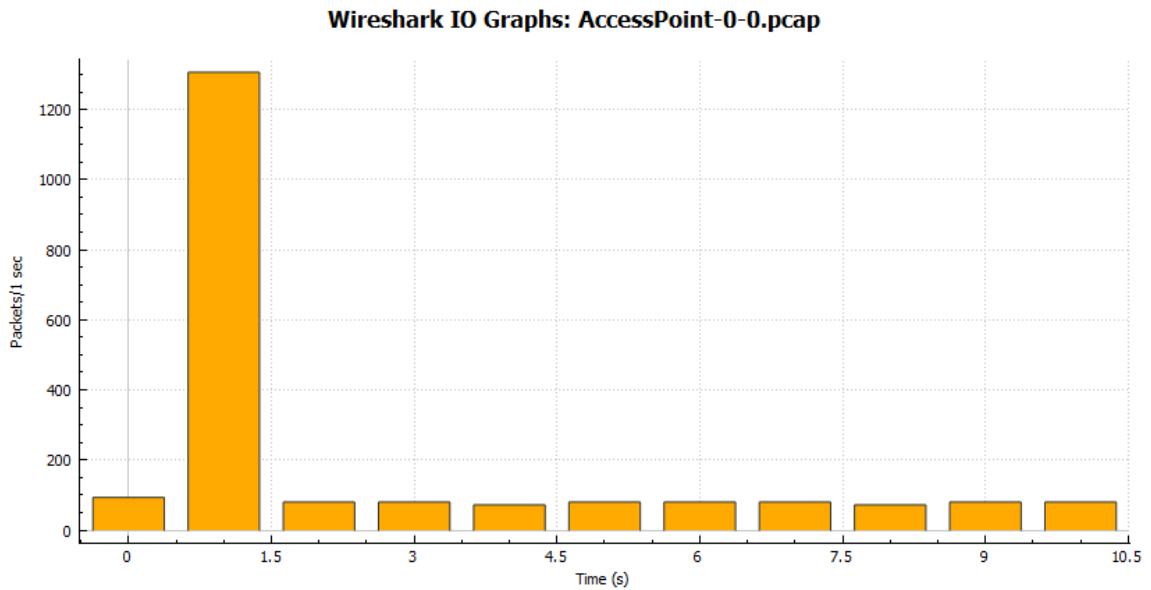

Figure 6.7: Time vs Packets/sec PCP/AP simulation for SPCA

For PCP/AP, there is significant packet generation at CBAP, therefore, the packets produced under UDP provide good throughput at figure 6.6. On the contrary, the SPCA figure 6.7 clearly showing that there is significantly less packet generated in simulation of SPCA. At the beginning of simulation the packet transmits slowly, with time it increases packet rate but at the end seconds it slows down to generate the packet.

Therefore from the above discussion of CBAP and SPCA analysis, it is to say, though there is debate on CSMA/CA in mmWave, the method still generating much packet than SPCA. But since contention is mandatory in CBAP to access the channel, there would be some period of waiting due to contention to access the channel. On the other hand, due lower packet generation, packet can easily get access to channel since SPCA is dedicated in terms of channel. But when packet generation becomes higher (throughput high), the communication medium become congested. As result, packet flow captured in Wireshark become zero after a certain period of simulation.

The flow graph of CBAP and SPCA are-

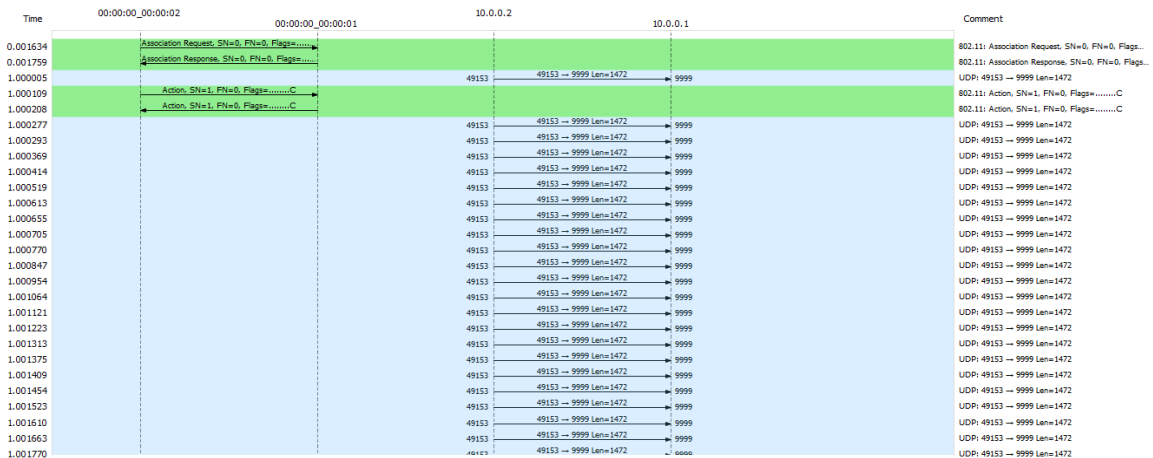

Figure 6.8: Flow Graph of CBAP under UDP

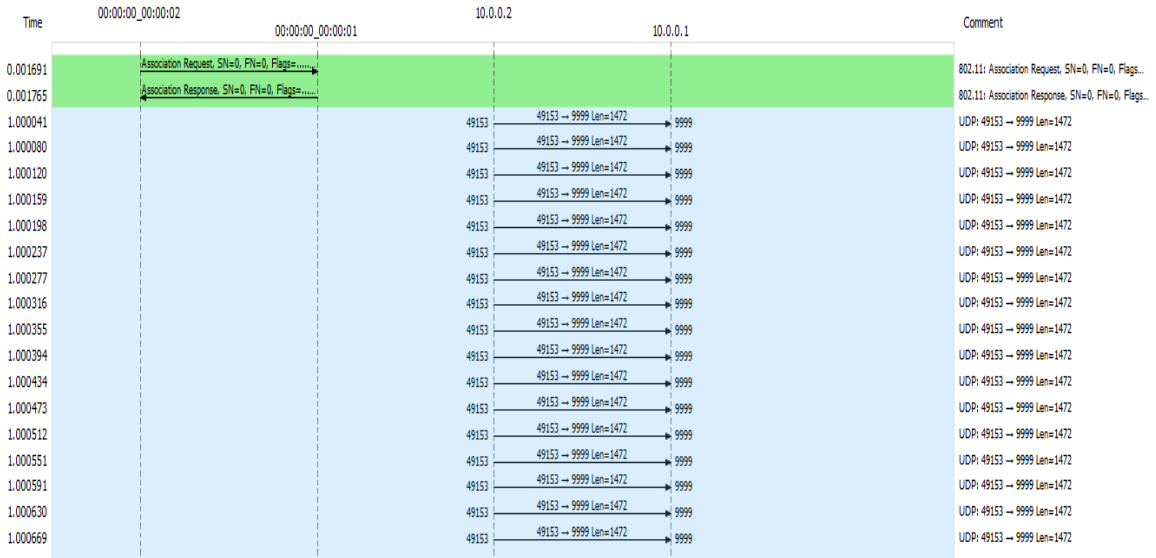

Figure 6.9: Flow Graph for SPCA under UDP

The above figure 6.8, in CBAP flow graph there is association request, association response and action frames. The STA moves for Associating with PCP/AP. The station is transmitting an Association Request frame which contains information about the STA. Upon receiving the Association Request Frame, PCP/AP reply back with the acknowledgment frame with Association Response frame. After successful frame acknowledgment, the Association ID is assigned to the STAs. After Association frame acknowledgment, action frame exchanged and DMG STA and PCP/AP establish connection. Moreover, PCP/AP flow graph does not have action frame acknowledgment. Therefore, in IEEE 802.11ad one DMG STA and single PCP/AP can communicate within a channel not only under the MCS12 SC PHY but also with MCS24 OFDM PHY. There will be still debate about CBAP and SPAC until new proposition is arriving, the proposition is our future task depending on this channel access scheme analysis.

Chapter Seven

Conclusion

From the second chapter to the last, WLAN has been discussed, along with the research objective. The channel access scheme is different by method but both of the method has merits and de merits. To handle the attenuation and losses in WiGig, channel access scheme requires more attention. In the analysis, Wireshark I/O graph, Association Frames has been narrated. From this books perspective some future work can be assumed. Since this book focuses on MAC layer, there is obviously a chance to organize analysis on Quality of Service (QoS) of WiGig. Additionally, there has always been a good option for Internet of Things devices presence around every place, so QoS can be proposed for our future work. Another key portion is, cross layer protocol in wireless sensor network also defines QoS [28]. Therefore, cross layer concept analysis can be drawn in WigGig hopefully.

A significant amount of hard work required to implement the channel access scheme analysis for directional 60GHz band. As described in chapter six, the main focus of this book is achieved successfully by installing the IEEE 802.11ad to ns-3, and simulation of the models to obtain the desired result.

References

- [1] L. A. N. Man, S. Committee, and I. Computer, *Part 11 : Wireless LAN Medium Access Control (MAC) and Physical Layer (PHY) Specifications Amendment 3 : Enhancements for Very High Throughput in the 60 GHz Band IEEE Computer Society*, vol. 2012, no. December. 2012.
- [2] L. A. N. Man, S. Committee, and I. Computer, *IEEE 802.11*, vol. 2012, no. March. 2011.
- [3] Q. A. Tri-band, "IEEE 802 . 11ad approval steps up marketplace WiGig," no. January, pp. 1–2, 2013.
- [4] B. Langen, G. Lober, and W. Herzig, "Reflection and transmission behaviour of building materials at 60 GHz," *IEEE Int. Symp. Pers. Indoor Mob. Radio Commun. PIMRC*, vol. 2, pp. 505–509, 1994.
- [5] G. R. Hiertz, S. Max, Z. Rui, D. Denteneer, and L. Berlemann, "Principles of IEEE 802.11s," *Proc. - Int. Conf. Comput. Commun. Networks, ICCCN*, pp. 1002–1007, 2007.
- [6] T. Paul and T. Ogunfunmi, "Evolution, insights and challenges of the PHY layer for the emerging IEEE 802.11n amendment," *IEEE Commun. Surv. Tutorials*, vol. 11, no. 4, pp. 131–150, 2009.
- [7] K. Yu, M. Arifuzzaman, Z. Wen, D. Zhang, and T. Sato, "A Key Management Scheme for Secure Communications of Information Centric Advanced Metering Infrastructure in Smart Grid," *IEEE Trans. Instrum. Meas.*, vol. 64, no. 8, pp. 2072–2085, 2015.
- [8] N. Nguyen, M. Arifuzzaman, and T. Sato, "A novel WLAN roaming decision and selection scheme for mobile data offloading," *J. Electr. Comput. Eng.*, vol. 2015, 2015.
- [9] Q. N. Nguyen, M. Arifuzzaman, T. Miyamoto, and S. Takuro, "An Optimal Information Centric Networking Model for the Future Green Network," *Proc. - 2015 IEEE 12th Int. Symp. Auton. Decentralized Syst. ISADS 2015*, pp. 272–277, 2015.
- [10] B. P. Crow, I. Widjaja, J. G. Kim, and P. T. Sakai, "IEEE 802.11 wireless local area networks," *IEEE Commun. Mag.*, vol. 35, no. 9, pp. 116–126, 1997.
- [11] M. May, "Modelling and Evaluation of 60 GHz IEEE 802 . 11 Wireless Local Area Networks in ns-3," vol. 1994, 2014.
- [12] Tektronix Inc., "Wi-Fi : Overview of the 802.11 Physical Layer and Transmitter Measurements," p. 44, 2013.
- [13] V. Rapper, "Te La R Te La R," vol. 32, no. 1965, pp. 33–44, 1890.
- [14] M. Arifuzzaman, M. Matsumoto, and T. Sato, "An intelligent hybrid MAC with traffic-differentiation-based QoS for wireless sensor networks," *IEEE Sens. J.*, vol. 13, no. 6, pp. 2391–2399, 2013.
- [15] Liz Ruetsch, "What's The Difference Between IEEE 802.11ac And 802.11ad?," *April*

- 23, 2013. [Online]. Available: <https://www.mwrf.com/technologies/test-measurement/article/21844955/whats-the-difference-between-ieee-80211ac-and-80211ad>.
- [16] M. Laatta, "Multi-Gigabit Wireless Communication at 60 GHz: Beamforming and Measurements," no. November, p. 80, 2016.
- [17] M. Jacob, S. Priebe, R. Dickhoff, T. Kleine-Ostmann, T. Schrader, and T. Kürner, "Diffraction in mm and sub-mm wave indoor propagation channels," *IEEE Trans. Microw. Theory Tech.*, vol. 60, no. 3 PART 2, pp. 833–844, 2012.
- [18] S. R. Theodore, "Wireless communications: principles and practice," in *Upper Saddle River*, Prentice Hall, 2002, p. 69.
- [19] C. Hansen, "INDUSTRIAL PERSPECTIVES WIG : Multi-Gigabit Wireless Communications in the 60 GHz Band," no. December, pp. 60–61, 2011.
- [20] Agilent Technologies, *wireless_LAN_at_60GHz_IEEE_802.11ad_explained*. 2013, pp. 1–28.
- [21] T. Nitsche, C. Cordeiro, A. B. Flores, E. W. Knightly, E. Perahia, and J. C. Widmer, "IEEE 802.11ad: Directional 60 GHz communication for multi-gigabit-per-second Wi-Fi," *IEEE Commun. Mag.*, vol. 52, no. 12, pp. 132–141, 2014.
- [22] H. Assasa and J. Widmer, "Implementation and evaluation of a WLAN IEEE 802.11ad model in ns-3," *ACM Int. Conf. Proceeding Ser.*, vol. Part F1321, pp. 57–64, 2016.
- [23] N. Shankar, D. Dash, H. Madi, and G. Gopalakrishnan, "WiGig and IEEE 802.11ad - For multi-gigabyte-per-second WPAN and WLAN," Nov. 2012.
- [24] C. Pielli, T. Ropitault, N. Golmie, and M. Zorzi, "An Analytical Model for CBAP Allocations in IEEE 802.11ad," pp. 1–14, 2019.
- [25] nsnam.org, "ns-3." [Online]. Available: <https://www.nsnam.org/>.
- [26] ns-3, "ns-3 model design." [Online]. Available: <https://www.nsnam.org/docs/models/html/wifi-design.html>.
- [27] H. Assasa and J. Widmer, "Extending the IEEE 802.11ad Model," no. June, pp. 39–46, 2017.
- [28] J. A. Haqbeen, T. Ito, M. Arifuzzaman, and T. Otsuka, "Intelligent Cross-Layer Protocol with traffic-differentiation-based QoS for wireless sensor networks," *IEEE Reg. 10 Annu. Int. Conf. Proceedings/TENCON*, pp. 1088–1092, 2017.