



# **Comparative Study for Confinement loss using Different Geometrical Configuration of Photonic Crystal Fiber**

Submitted by

S.M. Shihab-Ul-Hassan

ID: 2012-2-55-037

Khorshed Alam

ID: 2012-2-55-019

Supervised by

Mohammad Arif Iftekhar

Lecturer

**Department of Electronics and Communications**

**Engineering**

**East West University**

# Declaration

This report on the basis of our thesis paper and its enhancement of studies throughout our thesis work is submitted to follow the terms and conditions of the department of Electronics and Communications Engineering .This report is the requirement for the successive competition of B.Sc. in Electronic and Telecommunication Engineering.

We state that the report along with its literature that has been demonstrated in this report papers, is our own work with the masterly guidance and fruitful assistance of our supervisor for the finalization of our report successfully.

---

S.M. Shihab-Ul-Hassan  
ID: 2012-2-55-037

---

Khorshed Alam  
ID: 2012-2-55-019

Department of Electronics and Communications Engineering  
East West University

# Approval

The thesis title “Comparative Study for Confinement loss using Different Geometrical Configuration of Photonic Crystal Fiber” submitted by S.M. Shihab-UI-Hassan [ID: 2012-2-55-037], Khorshed Alam [ID: 2012-2-55-019] in the semester of Spring-2016 is approved satisfactory in partial fulfillment of the requirements for the degree of Bachelor of Science in Electronic and Telecommunication Engineering.

.....  
Mohammad Arif Iftekhar

Lecturer

Department of Electronics and Communications Engineering  
East West University

.....  
Dr. M. Mofazzal Hossain

Professor & Chairperson

Department of Electronics and Communications Engineering  
East West University

# Acknowledgment

It is with immense gratitude that we acknowledge the help of our supervisor, Mohammad Arif Iftikhar, faculty of Department of Electronics and Communications Engineering, East West University. Without his guidance, encouragement and support this thesis would have remained a dream. We consider it an honor to work with him. We are also indebted to our Parents, other Faculties of the department and friends for their support and encouragements. Finally thanks to almighty who gave us the patience to finish the task successfully.

# Abstract

In this thesis we deal with the Photonic crystal fiber. Here photonic crystal fiber was designed with different geometrical structures and shape. From these structures confinement losses were calculated using finite element method. Photonic Crystal Fibers were designed with various air hole rings with perfectly matched absorbing layer. COMSOL Multiphysics simulation software was used to design these structure and obtaining results. The value of pitch which means the distance between two air holes and the value of diameter of a particular hole were varied. From the simulated results, least confinement loss for a particular structure was suggested.

# Contents

---

## Chapter 1

### 1. Introduction

- 1.1 Optical fiber..... 2
- 1.2 Basic Structure of an Optical Fiber..... 3
- 1.3 Advantages of Fiber Optic Communication..... 4
- 1.4 Disadvantages of Fiber Optic Communication ..... 4
- 1.5 Applications ..... 5
- 1.6 Organization of this Thesis..... 5

## Chapter 2

### 2. Photonic Crystal Fiber (PCF)

- 2.1: Optics & Photonics ..... 6
- 2.2: Photonic Crystals ..... 9
- 2.3: History of Photonic Crystals..... 9
- 2.4: Application for Photonic Crystal ..... 10
- 2.5: Photonic Crystal Fiber..... 11
- 2.6: Index guiding photonic crystal fiber..... 12
- 2.7: Photonic crystal band fiber gap ..... 13
- 2.8: Fiber optic communication..... 13
- 2.9: Types of optical fiber..... 14
  - 2.9.1: Single-mode fiber..... 15
  - 2.9.2: Multi-mode fiber..... 15
    - 2.9.2.1: Step-index fiber..... 16

2.9.2.2: Graded-index fiber.....	17
2.10: Ray theory transmission.....	18
2.10.1: Total internal reflection.....	18
2.10.2: Acceptance Angle.....	19
2.10.3: Numerical Aperture.....	19
2.11: Maxwell equation .....	20
2.12: Sellmeier equation .....	21
2.13: Confinement Loss.....	22

## Chapter 3

### 3. Structural Design

3.1: Introduction .....	23
3.2: Design.....	23
3.2.1: Hexagonal Shape core with 2 core ring with $d/\Lambda = 0.575$ .....	23
3.2.2: Hexagonal Shape core with 2 core ring with $d/\Lambda = 0.572$ .....	24
3.2.3: Hexagonal Shape with 1 core with $d/\Lambda = 0.79$ .....	24
3.2.4: Triangular Shape .....	25
3.2.5: Elliptical Shape .....	25

## Chapter 4

### 4. Simulated Results

4.1: Introduction .....	26
4.2: Result.....	26
4.2.1: Hexagonal Shape core with 2 core ring with $d/\Lambda = 0.575$ .....	26
4.2.2: Hexagonal Shape core with 2 core ring with $d/\Lambda = 0.572$ .....	27
4.2.3: Hexagonal Shape with 1 core with $d/\Lambda = 0.79$ .....	27

4.2.4: Triangular Shape .....	28
4.2.5: Elliptical Shape .....	28

## **Chapter 5**

### **5. Conclusion & Discussion**

5.1: Discussion .....	29
5.2: Conclusion.....	29

## **Reference**



# Chapter 1

---

## INTRODUCTION

Technology plays an important role in our daily life. From the early dawn of civilization, from the deeper understanding of material many of the breakthroughs resulted. Without proper communications none of this could happen. The advancement from the Stone Age through the Iron Age is largely a story of humanity's increasing recognition of the utility of natural materials. In this progress of advancement, people learned to extract a material from the available natural resources of Earth whose fixed properties proved useful. Controlling over these materials gives more and more fascinating results.

Advances in semiconductor physics have allowed us to tailor the conducting properties of certain materials, thereby initiating the transistor revolution in electronics. It is hard to overstate the impact that the advances in these fields have had on our society. With new alloys and ceramics, scientists have invented high-temperature superconductors and other exotic materials that may form the basis of future technologies. [1]

In this century, a lot of invention has been made including the electrical properties of material. In the last few decades, a new aspect has opened up to control and understand the materials with their optical properties. This introduces a new era of technology. An enormous range of technological development would become possible if we could engineer materials that can control and manipulate light, because using photons instead of electrons for the communication on a single chip could be a solution to the propagation time delay problem, referred to as interconnect bottleneck. [2]

Photonics is the field of science that relates electronics and optics, and deals with the generation, propagation and detection of light. Thus, photonics is the control of photons. [3] It is the underlying technology supporting today's worldwide optical

communication network. New applications are emerging in the field of optical computing, biotechnology and sensors.

Fiber Optics is frequently utilized as a part of information transmission or light guide applications. Photonic crystal fibers (PCFs) are single material optical fibers with regular array of air holes running along the fiber which act as cladding, and guide the light. [4] The optical analogue is the photonic crystal, in which the atoms or molecules are replaced by macroscopic media with differing dielectric constants, and the periodic potential is replaced by a periodic dielectric function (or, equivalently, a periodic index of refraction). More than twenty years have passed since that time when the analogy between solid-state physics and optics led to the concept of photonic crystals (PCs) (Yablonovitch, 1987). Fast progress in theory and applications of PCs has been stimulated to a large extent by their unique properties that allow increasing the potential of light controlling. [5]

## **1.1 Optical Fiber**

Optical Fibers or Fiber Optics are frequently utilized as a part of information transmission or light guide applications. An optical straightforward fiber typically made of slender glass or plastic, through which light can be transmitted by progressive inward reflections. Optical Fibers utilized as a part of light guide applications transmit safe, no-warmth light, which is perfect for restorative, review, car, or showcase applications. A solitary Optical Fiber uses all out inner reflection to transmit light, permitting twists along its way. Negligible light misfortune amid transmission permits Optical Fibers to transmit light or information rapidly over long separations. Whenever packaged, Fiber Optics can transmit huge amounts of information for telecom applications. Light waves can be balanced to convey some other kind of sign, including sounds, electrical signs, and PC information, and a solitary fiber can convey many such flags at the same time, truly at the rate of light.

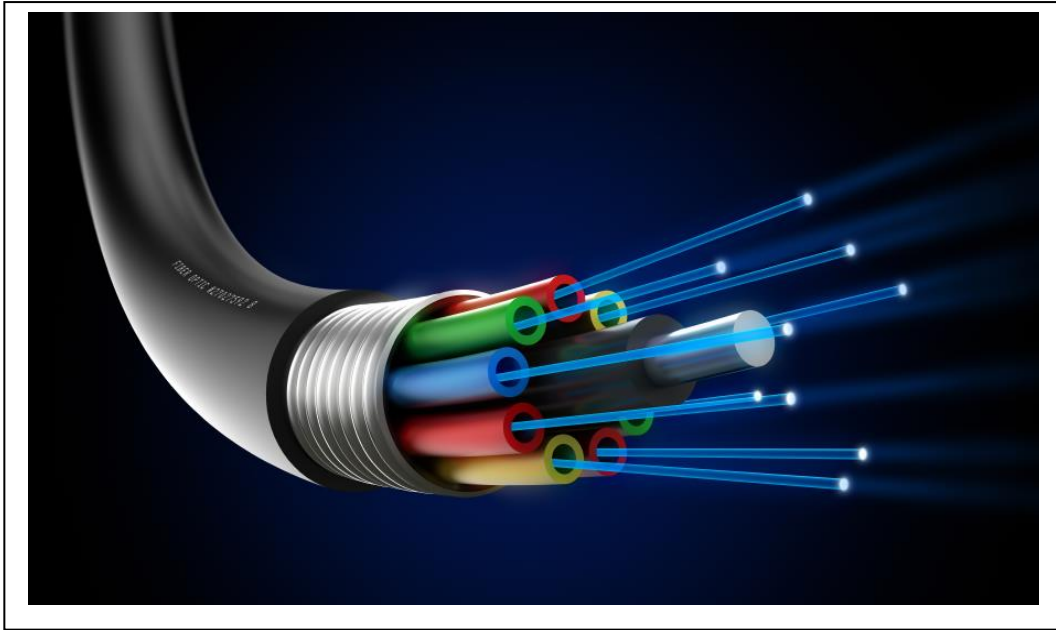

Figure 1.1: Fiber Optic Cable [6]

## 1.2 Basic Structure of An Optical Fiber

Optical fibers are consisted with three parts which are core, cladding, and coating or buffer. Core is a barrel shaped pole of dielectric material. In optical fiber, Light propagates along the core. The core is made of glass. The core is encompassed by a layer of material called the cladding. The index of refraction of the cladding material is not as much as that of the core material. The cladding is for the most part made of glass or plastic. For additional insurance, the cladding is surrounded in an extra layer called the coating or buffer. It is utilized to shield the optical fiber from physical harm. The material utilized for buffer that is a sort of plastic.

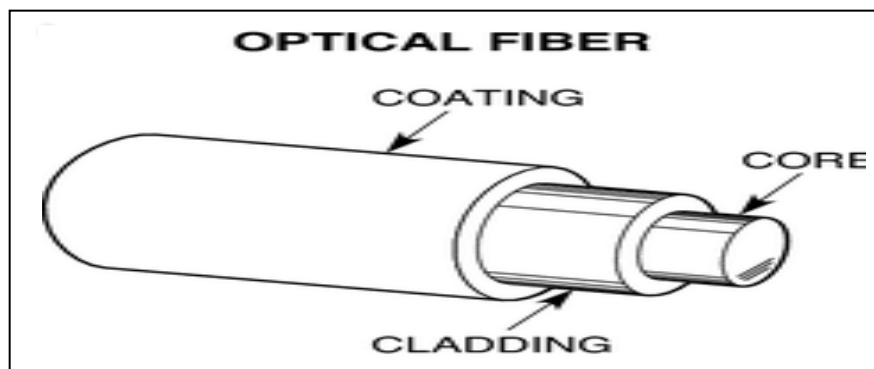

Figure 1.2: Basic Structure of An Optical Fiber [6]

### 1.3 Advantages of Fiber Optic Communication[4]

There are several advantages of fiber optic communication.

- a) **Enormous Potential Bandwidth:** The optical carrier frequency range is  $10^{13}$  to  $10^{16}$  Hz which has greater potential transmission than metallic cable systems.
- b) **Small Size and Weight:** Optical fibers have very small diameters which are often no greater than the diameter of a human hair.
- c) **Electrical Isolation:** Optical fibers which are fabricated from glass, or sometimes a plastic polymer, are electrical insulators and therefore, unlike their metallic counterparts, they do not exhibit earth loop and interface problems.
- d) **Immunity to Interference and Crosstalk:** Optical fibers form a dielectric waveguide and are therefore free from electromagnetic interference (EMI), radio-frequency interference (RFI), or switching transients giving electromagnetic pulses (EMPs).
- e) **Signal Security:** The light from optical fibers does not radiate significantly and therefore they provide a high degree of signal security. No significant radiation, optical signal cannot be obtained in a noninvasive manner.
- f) **Robustness & Flexibility:** Fiber cables have high tensile strength, compact, small bend radii, flexible.
- g) **Lower Loss:** Optical fiber has lower attenuation (loss of signal intensity) than copper conductors, allowing longer cable runs and fewer repeaters.

### 1.4 Disadvantages of Fiber Optic Communication[5]

- a) **Cost of fiber optics cable:** Fiber optics is still quite expensive as compared to the copper wire, though the prices are coming down rapidly. It is possible to multiplex many video signals on a single fiber optics cable and thereby reduce cabling and installation cost.
- b) **Termination:** Termination of fiber optics cable is complex and requires special tools, better precision of workmanship and is more time consuming

and therefore more expensive. Fiber optics cable has a very small diameter and requires specialized tools to align the cables correctly and then join them.

- c) **Cable Laying:** The centre core of a fiber optics cable is made of glass. Extra precaution is required during cabling. Stretching of cable should be avoided as the glass core may crack.

## **1.5 Applications [7]**

Fiber optic has several types of applications. Some of them are mentioned as follows

- I. Telecommunication
- II. Computer Networking
- III. Fiber optics sensors
- IV. Biomedicine
- V. Imaging
- VI. Spectroscopy
- VII. Metrology
- VIII. Industrial machining
- IX. Military technology.
- X. Medical endoscope & Baroscopic

## **1.6 Organization of this Thesis**

The salient features of Photonic Crystals, namely 2D photonic crystals, Photonic Crystal Fiber and Confinement Loss are introduced in Chapter 2.

Chapter 3 provides the design procedures for the different Photonics Crystal Fiber structures which have a complete confinement loss.

Chapter 4 displays the various findings derived from the simulated results in confinement loss. The results obtained are followed by a qualitative analysis.

In Chapter 5, the findings are summarized. The limitations of the present study and the options for future endeavors have also been mentioned.

# Chapter 2

---

## Photonic Crystal Fiber

### 2.1 Optics & Photonics

Everyone knows of the widespread prevalence of electronics in modern life but relatively few people are aware of the increasing use of photonics. In fact probably without realizing, many of us already use photonics in our everyday lives. It is found in compact disc and DVD players, office printers, supermarket checkouts, as well as in hospitals and numerous other places. Most important of all, photonics is the underlying technology supporting today's worldwide telecommunications networks and the internet. Increasingly photonics is also being used in the most powerful computers [8].

Photonics is the use of light to obtain, convey or process information. The application of electromagnetic energy whose basic unit is the photon, incorporating optics, laser technology, electrical engineering, materials science, and information storage and processing. The scientific application of electromagnetic energy whose basic unit is the photon, incorporating optics, laser technology, electrical engineering, materials science, and information storage and processing.

Photonic technology is found in laser. Lasers are made by quantum mechanical effect called stimulated emission. You need to have two components to make a laser a gain medium and an optical cavity. Lasers are used for many things like laser eye surgery, CD drives, guiding system, office printer, powerful computer etc. It can be sold as a house hold product, industrial machinery, medical equipment, or scientific technology [9].

In photonic systems, information signals are conveyed as pulses of light, rather than electricity, and these optical signals are transmitted by sending them along optical fibers strands of special glass around 100 $\mu$ m in diameter. One of the great advantages of photonics is that these fibers can carry thousands of times more information than electrical wires. Photonic devices are used to convert electrical signals to optical

signals and back again where necessary, when they enter and leave the fibers. Photonic devices are also beginning to be used to manipulate and process optical signals directly, without the need for conversion. Photonic devices can be fabricated from a wide variety of materials, including semiconductors, and even optical fibers themselves [8].

Light consists of particles called photons. A photon has zero rest mass and carries electromagnetic energy and momentum. It also carries an intrinsic angular momentum (or spin) that governs its polarization properties. The photon travels at the speed of light in vacuum ( $c_0$ ); its speed is retarded in matter. Photons also have a wavelike character that determines their localization properties in space and the rules by which they interfere and diffract. The notion of the photon initially grew out of an attempt by Planck to resolve a long-standing riddle concerning the spectrum of blackbody radiation. He finally achieved this goal by quantizing the allowed energy values of each of the electromagnetic modes in a cavity from which radiation was emanating. The concept of the photon and the rules of photon optics are introduced in this section by considering light inside an optical resonator (a cavity). This is a convenient choice because it restricts the space under consideration to a simple geometry. The presence of the resonator turns out not to be an important restriction in the argument; the results can be shown to be independent of its presence [3].

These advantages as well as the growing numbers of practical applications make photonics an important field both for research and commercial development.

Photonic systems research is truly cross-disciplinary activity, involving physics, electrical engineering, computer science and other fields of science.

Photonics is closely related to optics. Classical optics long preceded the discovery that light is quantized, when Albert Einstein famously explained the photoelectric effect in 1905. Optics tools include the refracting lens, the reflecting the mirror, and various optical components and instruments developed throughout the 15<sup>th</sup> to 19<sup>th</sup> centuries. Key tenets of classical optics, such as Huygens principle, developed in the 17<sup>th</sup> century, Maxwell's Equations and the wave equations, developed in the 19<sup>th</sup>, do not depend on quantum properties of light [10].

**Table 2.1: Similarities in characteristics of Photons and Electrons [11]**

Characteristics	Photon	Electron
Wavelength	$\lambda = \frac{h}{p} = \frac{c}{\nu}$	$\lambda = \frac{h}{p} = \frac{h}{mv}$
Eigen value (wave) equation	$\{\nabla \times \frac{1}{\epsilon_r} \nabla \times\} B(r) = (\omega/c)^2 B(r)$	$\hat{H}\psi(r) = -\frac{\hbar^2}{2m} (\nabla \cdot \nabla + v(r))$ $\psi(r) = E \psi$
Free-space Propagation	Plane Wave $E = (1/2)E^0(e^{ik \cdot r - \omega t} + e^{-ik \cdot r + \omega t})$ K= wave vector, a real quantity.	Plane Wave $\Psi = c (e^{ik \cdot r - \omega t} + e^{-ik \cdot r + \omega t})$ K= wave vector, a real quantity.
Interaction Potential in a Medium	Dielectric constant (refractive index)	Coulomb interactions
Propagation Through a Classically Forbidden Zone	Photon tunneling (evanescent wave) with wave vector, k, imaginary and hence amplitude decaying exponentially in the forbidden zone.	Electron- tunneling with the amplitude (probability) decaying exponentially in the forbidden zone.
Localization	Strong scattering derived from large variations in dielectric constant (e.g., in photonic crystals).	Strong scattering derived from large variations in coulomb interactions (e.g., in electronic semiconductor crystals)
Cooperative	Nonlinear optical interactions	Many-body correlation Superconducting Cooper pairs Biexciton formation.



## **2.2 PHOTONIC CRYSTALS**

Photonic crystals are composed of periodic dielectric or metallic-dielectric structures that are designed to affect the propagation of electromagnetic waves in the same way as the semiconductor affects the propagation of electrons. Consequently, photons in PC can have band structures, localized defect modes, surface modes, etc. This new ability to mold and guide light leads naturally to many novel phenomena associated with light. The absence of allowed propagating EM modes inside the structures, in a range of wavelengths called a photonic band gap (PBG), gives rise to distinct optical phenomena such as inhibition of spontaneous emission and low-loss waveguides. Of particular interest is a PC whose band structure possesses a complete photonic band gap. A complete photonic band gap defines a range of frequencies for which light is forbidden to propagate in all directions. [12]

The optical analogue is the photonic crystal, in which the atoms or molecules are replaced by macroscopic media with differing dielectric constants, and the periodic potential is replaced by a periodic dielectric function (or, equivalently, a periodic index of refraction). If the dielectric constants of the materials in the crystal are sufficiently different, and if the absorption of light by the materials is minimal, then the refractions and reflections of light from all of the various interfaces can produce many of the same phenomena for photons (light modes) that the atomic potential produces for electrons. One solution to the problem of optical control and manipulation is thus a photonic crystal, a low-loss periodic dielectric medium. In particular, we can design and construct photonic crystals with photonic band gaps, preventing light from propagating in certain directions with specified frequencies (i.e., a certain range of wavelengths, or “colors,” of light). We will also see that a photonic crystal can allow propagation in anomalous and useful ways.[13]

## **2.3 History of Photonic Crystals [14]**

The simplest form of a photonic crystal is a one-dimensional periodic structure, such as a multilayer film (a Bragg mirror); electromagnetic wave propagation in such systems was first studied by Lord Rayleigh in 1887, which showed that any such one-dimensional system has a band gap. One dimensional periodic system continued to be studied extensively, and appeared in applications from reflective coatings where the reflection band corresponds to the photonic band gap and to distributed feedback

(DFB) diode lasers where a crystallographic defect is inserted in the photonic band gap to define the laser wavelength. Two dimensional periodic optical structures, without band gaps, received limited study in the 1970s and 1980s. The possibility of two- and three-dimensionally periodic crystals with corresponding two- and three-dimensional band gaps was not suggested until 100 years after Rayleigh, by Eli Yablonovitch and Sajeev John in 1987, and such structures have since seen growing interest by a number of research groups around the world, with potential applications including LEDs, optical fiber, nanoscopic lasers, ultra white pigment, radio frequency antennas and reflectors, and photonic integrated circuits. Many research groups who explore controlling the pace of light emission using 3D photonic crystals have verified the 17-year old prediction of American physicist \*Eli Yablonovitch that ignited a world-wide rush to build tiny "chips" that control light beams. Researchers say it has many potential uses, not only as a tool for controlling quantum optical systems, but also in efficient miniature lasers for displays and telecommunications, in solar cells, and even in future quantum computers.

## 2.4 Applications for Photonic Crystals [14]

Here are some applications of photonic crystals, which of them are already commercialized and some are under development.

**Table 2.2: Application of Photonic Crystal**

DEVICE	DESCRIPTION	STATUS
OPTICAL FIBERS	2-D band-gap material stretched along the third dimension	Early versions already commercialized
NANOSCOPIC LASERS	World's tiniest optical cavities and tiniest lasers; formed in a thin film 2-D band-gap material	Demonstrated in the lab
ULTRAWHITE PIGMENT	Incomplete 3-D bad-gap material, usually patterned as opal structure	Demonstrated; low-cost manufacturing methods under development
RADIO-FREQUENCY	Uses inductors and capacitors in place of ordinary dielectric	Demonstrated for magnetic resonance imaging and

ANTENNAS, REFLECTORS	materials	antennas
LIGHT-EMITTING DIODES	Photonic band-gap structure can extract light very efficiently [better than %50]	Demonstrated; but must compete with other methods of achieving the same goal
PHOTONIC INTEGRATED CIRCUITS	2-D thin films can be patterned like conventional integrated circuits to make channel filters, modulators, couplers and so	Under development

## 2.5 Photonic Crystal Fiber [15]

Photonic crystal fibers (PCFs), which are also called microstructured optical fibers or holey fibers, have been extensively investigated and have considerably altered the traditional fiber optics since they appeared in the mid 1990s [Knight et al., 1996; Knight, 2003; Russell, 2003]. PCFs have a periodic array of micro holes that run along the entire fiber length. They typically have two kinds of cross sections: an air-silica cladding surrounding a solid silica core or an air-silica cladding surrounding a hollow core. The light-guiding mechanism of the former is provided by means of a modified total internal reflection (index guiding), while the light-guiding mechanism of the latter is based on the photonic band gap effect (PBG guiding). The number, size, shape, and the separation between the air-holes as well as the air-hole arrangement are what confer PCFs unique guiding mechanism and modal properties [Russell, 2006]. This gives PCF many unique properties such as single mode operation over a wide wavelength range [Birks et al., 1997], very large mode area [Knight et al., 1998], and unusual dispersion [Renversez et al., 2003].

While optical interferometers offer high resolution in metrology applications, the fiber optic technology additionally offers many degrees of freedom and some advantages such as stability, compactness, and absence of moving parts for the construction of interferometers. The two commonly followed approaches to build fiber optic interferometer are: two arm interferometer and modal interferometer. Two- arm interferometer involves splitting and recombining two monochromatic optical beams that propagate in different fibers which requires several meters of optical fiber and

one or two couplers. Modal interferometer exploits the relative phase displacement between two modes of the fiber. In modal interferometers compared to their two-arm counterparts the susceptibility to environmental fluctuations is reduced because the modes propagate in the same path or fiber.

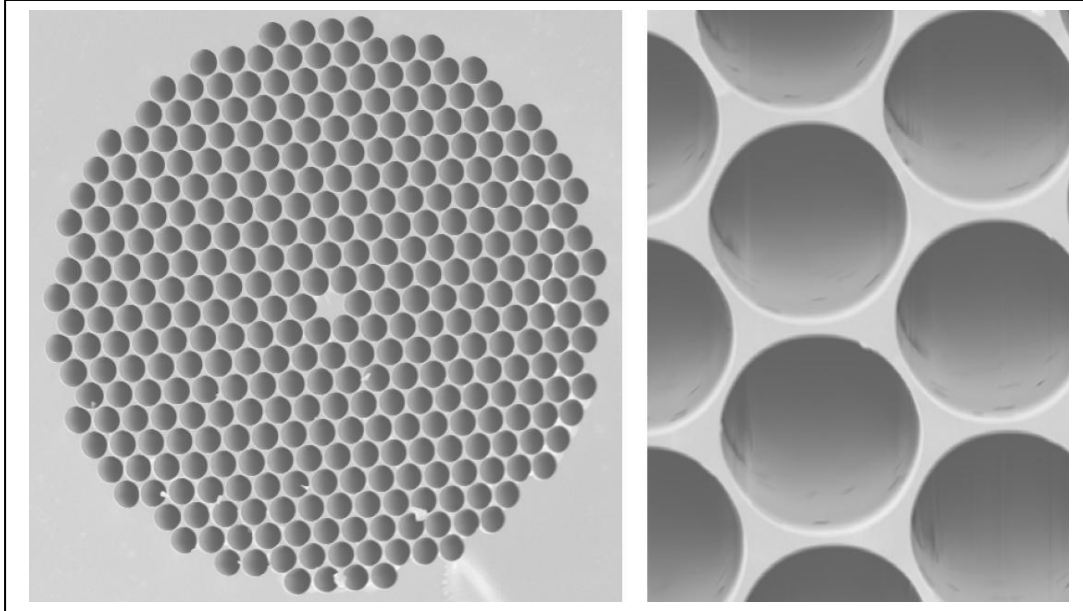

Figure 2.1: Photonic Crystal Fiber [15]

## 2.6 Index Guiding Photonic Crystal Fiber [16]

There is greater index contrast since the cladding contains air holes with a refractive index of 1 in comparison with the normal silica cladding index of 1.457 which is close to the germanium-doped core index of 1.462. A fundamental physical difference, however, between index-guided PCFs and conventional fibers arises from the manner in which the guided mode interacts with the cladding region. Whereas in a conventional fiber this interaction is largely first order and independent of wavelength, the large index contrast combined with the small structure dimensions cause the effective cladding index to be a strong function of wavelength. For short wavelengths the effective cladding index is only slightly lower than the core index and hence they remain tightly confined to the core. At longer wavelengths, however, the mode samples more of the cladding and the effective index contrast is larger. This wavelength dependence results in Photonic crystal fibers 75 a large number of unusual optical properties which can be tailored. For example, the high index contrast enables the PCF core to be reduced from around 8  $\mu\text{m}$  in conventional fiber to less than 1  $\mu\text{m}$ , which increases the intensity of the light in the core and enhances the nonlinear effects.

## 2.7 Photonic Crystal Band Gap Fiber [7]

Have periodic microstructure elements and a core of low-index material. The core region has a lower refractive index than the surrounding photonic crystal cladding [18]. The light is guided by a mechanism that differs from total internal reflection in that it exploits the presence of the photonic band gap.

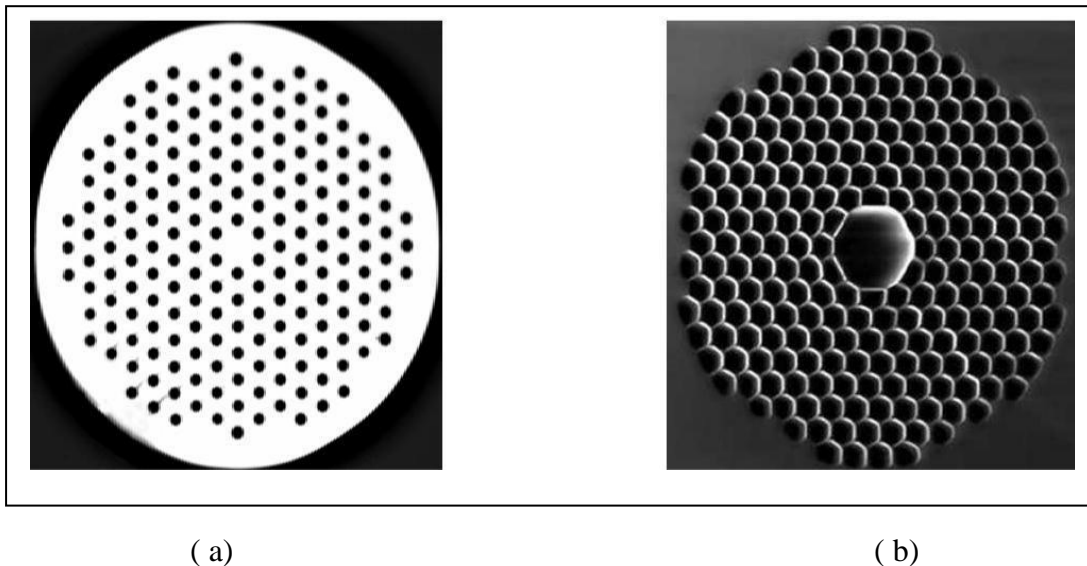

Figure 2.2: Structure of (a) index guiding photonic crystal fiber, (b) photonic crystal bandgap fiber. [14]

## 2.8 Fiber optic Communication [16]

An optical fiber communication system is similar in basic concept to any type of communication system. A block schematic of a general communication system is shown in Figure 2.3 (a), the function of which is to convey the signal from the information source over the transmission medium to the destination. The communication system therefore consists of a transmitter or modulator linked to the information source, the transmission medium, and a receiver or demodulator at the destination point. In electrical communications the information source provides an electrical signal, usually derived from a message signal which is not electrical (e.g. sound), to a transmitter comprising electrical and electronic components which converts the signal into a suitable form for propagation over the transmission medium. This is often achieved by modulating a carrier, which, as mentioned previously, may be an electromagnetic wave. The transmission medium can consist of a pair of wires, a coaxial cable or a radio link through free space down which the signal is transmitted to the receiver, where it is transformed into the original electrical information signal (demodulated) before being passed to the destination.

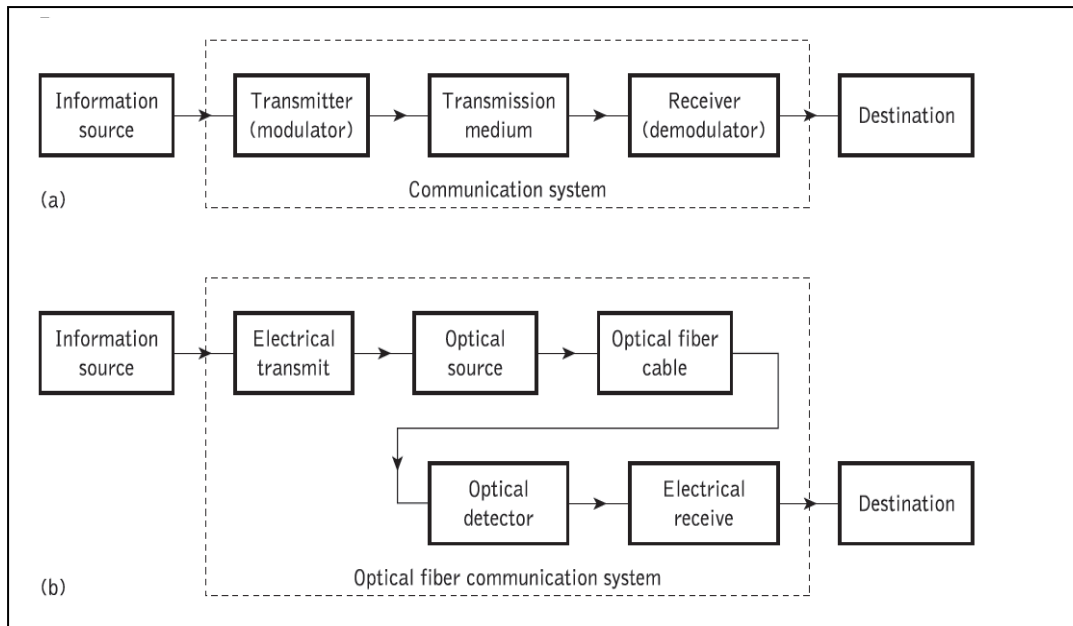

Figure 2.3: (a) The general communication system (b) The optical fiber communication system [16]

For optical fiber communications the system shown in Figure 2.3 (a) may be considered in slightly greater detail, as given in Figure 2.3 (b). In this case the information source provides an electrical signal to a transmitter comprising an electrical stage which drives an optical source to give modulation of the light wave carrier. The optical source which provides the electrical–optical conversion may be either a semiconductor laser or light-emitting diode (LED). The transmission medium consists of an optical fiber cable and the receiver consists of an optical detector which drives a further electrical stage and hence provides demodulation of the optical carrier.

## 2.9 Types of Optical Fiber [15]

Optical fibers can be defined as two basic types:

- 1) Conventional Optical Fiber:
  - i) Single-mode Fiber
  - ii) Multi-mode Fiber:
    - a) Step-index Fiber
    - b) Graded-index Fiber
- 2) Photonic crystal fiber:
  - i) Index Guiding Photonic Crystal Fiber
  - ii) Photonic Crystal Band Gap Fiber

### 2.9.1 Single-mode Fiber

In optical fiber system, single mode fiber is optical fiber that is intended for the transmission of a single beam or method of light as a carrier and is utilized for long-remove signal transmission. In a single mode fiber, the core diameter is reduced to few wavelengths of the incoming light. For example for a beam with  $\lambda = 0.55 \mu\text{m}$ , the core diameter should be of the order of  $4.5 \mu\text{m}$ . Under these circumstances, the core is so small that only the primary mode can travel inside the fiber. Given the wave propagation of the light inside the cavity, there is no way for the light to take longer optical paths that the wave travelling on the axis. This is the reason why single mode fibers are used in telecommunications to deliver high baud rates: the width of a short single square light pulse entering into the fiber will enlarge less in a single mode fiber than in a multimode one. In a multimode fiber the different modes travelling “slower” will spread the pulses [17]. This implies the core to cladding measurement proportion is 9 microns to 125 microns.

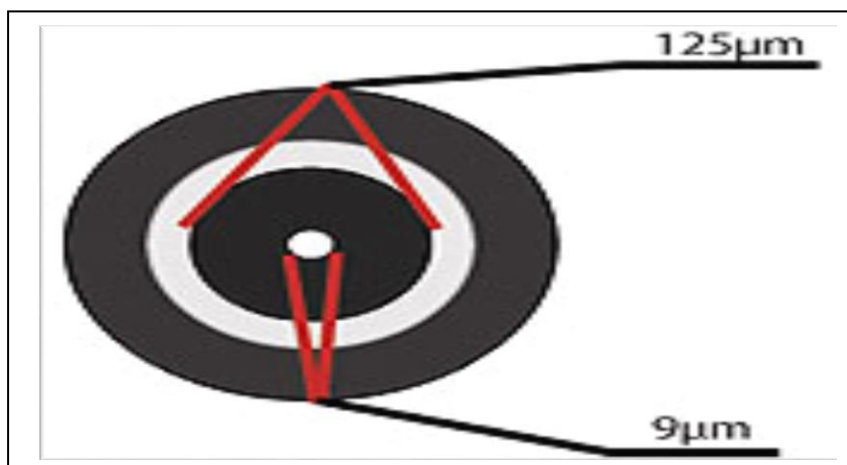

Figure 2.4: Single-mode Fiber [6]

### 2.9.2 Multi-mode Fiber [16]

In Multi-mode optical fiber, the core is a large diametrical that propagates numerous mode of light. As a result of this, the quantity of light reflections made as the light goes through the core increments, making the capacity for more information to go through at a given time. Due to the high scattering and weakening rate with this kind of fiber, the nature of the light is reduced over long separations. This application is normally utilized for short separation, information and sound/video applications in

LANs. The core to cladding diameter ratio is 50 microns to 125 microns and 62.5 microns to 125 microns. A fundamental detail of a multi-mode fiber contains the core distance across and the external breadth of a multi-mode fiber.

### **2.9.2.1 Step-index Fiber [18]**

Step index fibers are the most used fibers in fields other than telecommunications. They are relatively cheap and they have the widest range of core diameters: basically from 50  $\mu\text{m}$  up to 2 mm. The material may be plastic, liquid or glass. Plastic fibers are not wide used nowadays; their optical transmission is poor and the core relatively big (0.5 to 2 mm). The most efficient fibers are made in acrylic and they are mainly used for short length telecommunication networks. In spite of their limited performances, new developments in plastic fibers might open applications in the field of high speed home networks (Gigabit/s). New polymers are being proposed with attenuations approaching the silica fibers

Most common step index fibers are made in silica glass (core and cladding) because of its high optical transmission in a very broad spectral range. However during the manufacturing of fibers some contaminants remain in the glass which alters its transmission. The most difficult to remove are OH radicals. A large amount of these radicals generate absorption bands in the near IR range (726nm, 880nm, 950nm, 1136nm mainly) but fortunately leave a high transmission in the near UV region that is close to the theoretical limit (Rayleigh dispersion). High purity silica fibers with low amounts of OH contaminants greatly reduce these absorption peaks in the near IR. However, crystalline structures appear while manufacturing preventing a good transmission in the UV range.



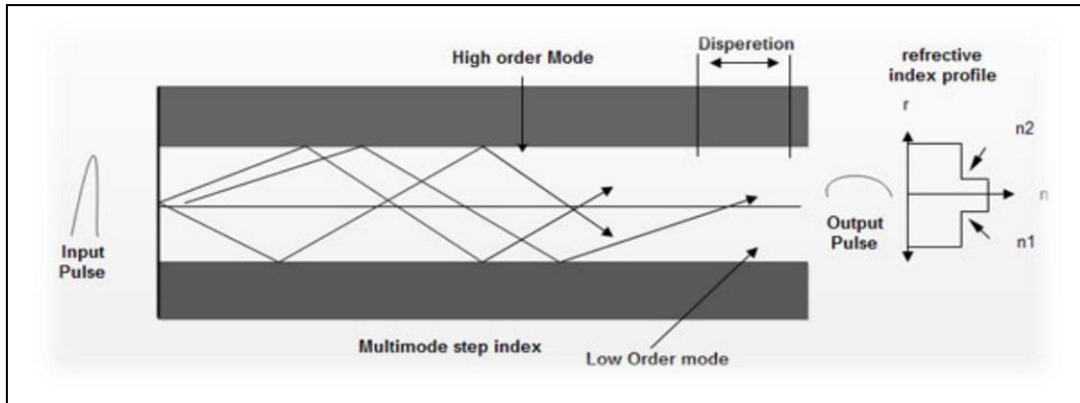

Figure 2.5: Step index fiber [18]

### 2.9.2.2 Graded-index Fiber

Graded index fiber also known as gradient index fiber which consists of a core with a decreasing refractive index as the radial index increases. Light rays do not propagate in a straight line but rather are constantly refracted towards the fiber axis in a parabolic index profile because of having a higher refractive index core than the parts near the fiber cladding. For the light to be guided by the fiber, the refractive index of the core must be slightly higher than that of the cladding. The bandwidths can be increased two or three orders larger than that of Step Index fiber. Gradient fiber are widely used in telecommunications, they are inexpensive and easy to procure. However, as far as we know, never for astronomical instrumentation. There is a common belief among instrumentalists that gradient fiber show low transmission in the blue region [19].

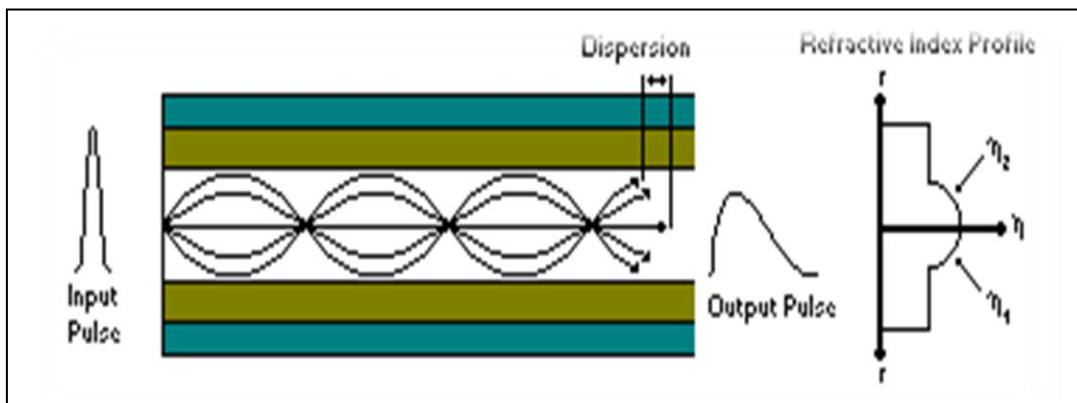

Figure 2.6: Graded index fiber [6]

## 2.10 Ray Theory Transmissions

### 2.10.1 Total internal reflection

If the light travels from one medium to another medium, then the light changes speed and is refracted. If the light rays are travelling from a less dense material to a dense medium they are refracted towards the normal and if they are travelling from a more dense medium to less dense medium they are refracted away from the normal. For total internal reflection to occur the light must travel from a more dense medium to a less dense medium. Example: glass to air or water to air. With the increases of the angle of incidence, the angle of refraction increases. When the angle of incidence reaches at a point known as the critical angle the refracted rays travel along the surface of the medium that means the light refracted to an angle of  $90^\circ$ . In order for total internal reflection to take place:

>The rays of light must travel from a dense medium to a less dense medium.

>The angle of incidence must be greater than the critical angle.

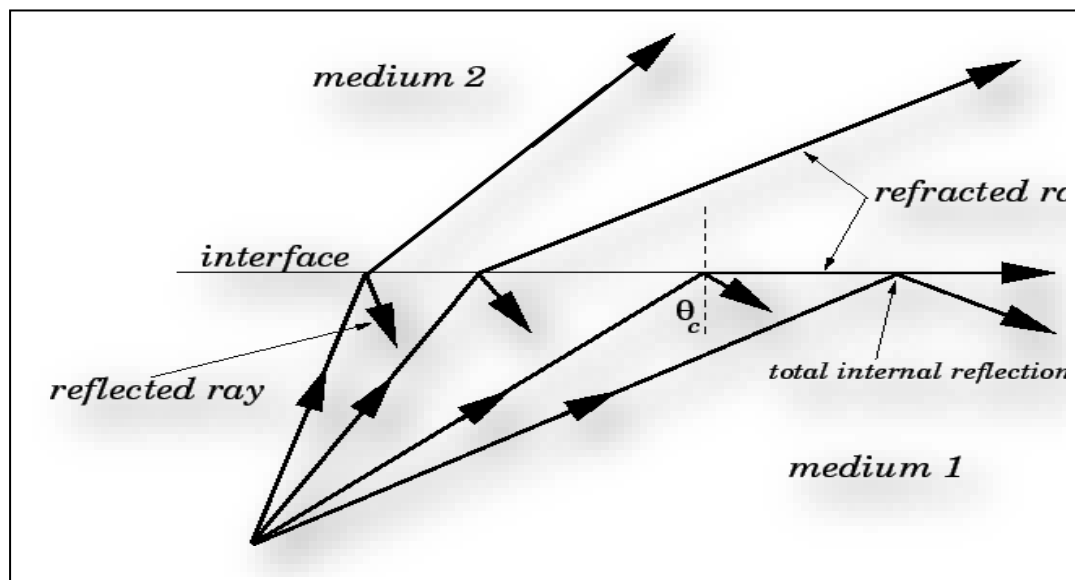

Figure 2.7: Total Internal Reflection [15]

## 2.10.2 Acceptance Angle [16]

Having considered the propagation of light in an optical fiber through total internal reflection at the core-cladding interface, it is useful to enlarge upon the geometric optics approach with reference to light rays entering the fiber. Since only rays with a sufficiently shallow grazing angle at the core-cladding interface are transmitted by total internal reflection, it is clear that not all rays entering the fiber core will continue to be propagated down its length. The geometry concerned with launching a light ray into an optical fiber is shown in Figure 2.8, which illustrates a meridional ray A at the critical angle  $\phi_c$  within the fiber at the core-cladding interface. It may be observed that this ray enters the fiber core at an angle  $\theta_a$  to the fiber axis and is refracted at the air-core interface before transmission to the core-cladding interface at the critical angle. Hence, any rays which are incident into the fiber core at an angle greater than  $\theta_a$  will be transmitted to the core-cladding interface at an angle less than  $\phi_c$ , and will not be totally internally reflected. Where the incident ray B at an angle greater than  $\theta_a$  is refracted into the cladding and eventually lost by radiation. Thus for rays to be transmitted by total internal reflection within the fiber core they must be incident on the fiber core within an acceptance cone defined by the conical half angle  $\theta_a$ . Hence  $\theta_a$  is the maximum angle to the axis at which light may enter the fiber in order to be propagated, and is often referred to as the acceptance angle for the fiber.

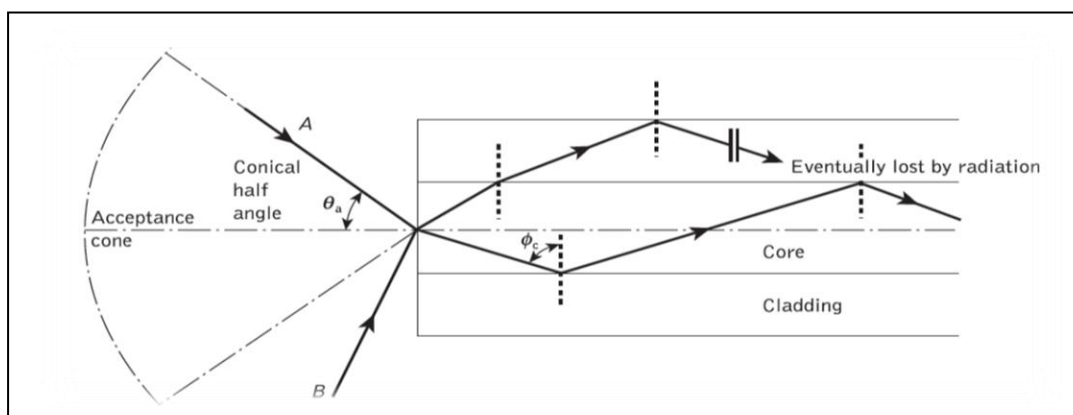

Figure 2.8: The acceptance angle  $\theta_a$  when launching light into an optical fiber [18]

## 2.10.3 Numerical Aperture [16]

The Numerical Aperture is an important parameter of optical fiber. The numerical aperture (NA) of the fiber can be described as it is the sine of the maximum angle of

an incident beam as for the fiber axis, so that the transmitted beam is guided in the core. It can also be defined in terms of the index of refraction of the fiber core and cladding. Here due to Snell's law, a critical angle exist above which all of the light at a fiber-cladding interface will experience total internal reflection this means there is a maximum acceptance angle at which light can enter the fiber. Following Snell's law, the maximum acceptance angle can be determined:

$$\sin\theta_c = n_c/n_f = \cos\theta_t \quad (2.1)$$

$$n_c/n_f = \sqrt{(1-\sin^2\theta_t)} \quad (2.2)$$

$$NA = n_i \sin\theta_a = \sqrt{(n_f^2 - n_c^2)} \quad (2.3)$$

Where:

$n_f$  is the index of refraction of the fiber core,  $n_c$  is the index of refraction of the cladding,

$\theta_c$  is the critical angle for total internal reflection, and

$\theta_a$  is the maximum 1/2 acceptance angle.

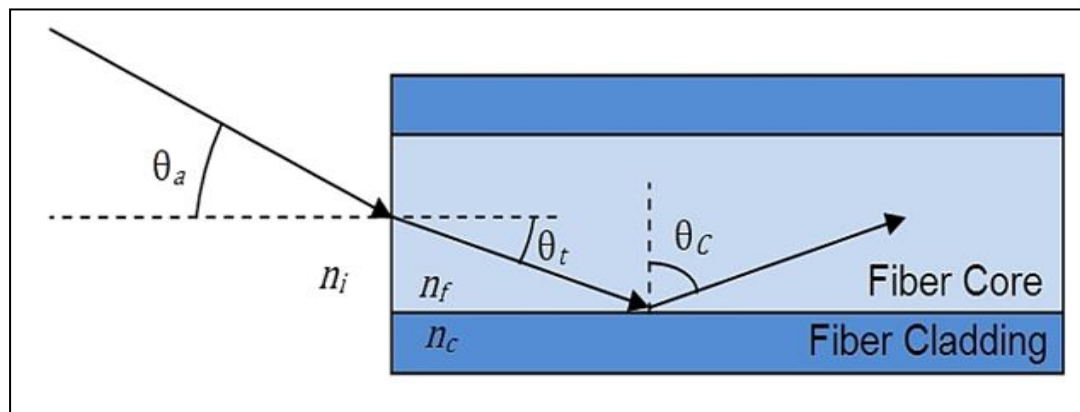

Figure 2.9: A ray with acceptance angle into fiber [16]

## 2.11 Maxwell equation [7]:

To study the propagation of light in a photonic crystal we use the Maxwell equation.

So including the propagation of light in a photonic crystal, the Maxwell equation in SI unit is given below:

$$\text{Faraday's Law: } \nabla \times \mathbf{E} = -\partial \mathbf{B} / \partial t \quad (2.4)$$

$$\text{Ampere's Law: } \nabla \times \mathbf{H} = \mathbf{J} + \partial \mathbf{D} / \partial t \quad (2.5)$$

$$\text{Gauss's Law: } \nabla \cdot \mathbf{D} = \rho \quad (2.6)$$

$$\text{Gauss's Law: } \nabla \cdot \mathbf{B} = 0 \quad (2.7)$$

Where  $\mathbf{E}$  is the electric field,  $\mathbf{H}$  is the magnetic field,  $\mathbf{B}$  is the magnetic flux density,  $\mathbf{D}$  is the electric displacement,  $\mathbf{J}$  is the electric current density and  $\rho$  is the electric charge density.

So the Maxwell curl equation,

$$\nabla \times \mathbf{E} + \partial \mathbf{B} / \partial t = 0 \quad (2.8)$$

$$\nabla \times \mathbf{H} - \partial \mathbf{D} / \partial t = \mathbf{J} \quad (2.9)$$

## 2.12 Sellmeier equation [7]:

Sellmeier equation is an empirical relationship between refractive index and wavelength for particular transparent and non-transparent medium. This equation is used to determine the dispersion of light. So the equation is defined as

$$n_{eff}^2 = 1 + \frac{B_1 \lambda^2}{\lambda^2 - L_1} + \frac{B_2 \lambda^2}{\lambda^2 - L_2} + \frac{B_3 \lambda^2}{\lambda^2 - L_3} \quad (2.10)$$

Where  $n_{eff}$  is the refractive index,  $\lambda$  is the wavelength, and  $B_1, B_2, B_3$  and  $L_1, L_2, L_3$  are the coefficients of Sellmeier equation.

Table 2.3 : Coefficients and values of Sellmeier equation. [9]

Coefficient	Value
B1	0.6961663
B2	0.4079426
B3	0.8974794
L1	0.0684043e-6
L2	0.1162414e-6
L3	9.896161e-6

## 2.13 Confinement Losses [20]

In the solid core MOFs that we will study, light guidance is due to modified total internal reflection between the core and a micro structured cladding consisting of inclusions in a matrix. The core and matrix material are generally the same, and hence have the same refractive index. In practice, the cladding has a finite width, as it consists of several rings of inclusions. Beyond the micro structured part of the fiber, the matrix extends without any inclusions until the jacket is reached. If we consider the jacket to be far from the cladding and core, and hence neglect its influence, guidance in the core is solely due to a finite number of layers of holes in bulk silica extending to infinity. A priori, the cladding does not "insulate" the core from the surrounding matrix material since the holes do not merge with their neighbors and consequently the matrix is connected between the core and the exterior. Physically, we can imagine the light leaking from the core to the exterior matrix material through the bridges between holes, and thus expect losses. In the modified total internal reflection model of guidance, in which the microstructured part of the fiber is replaced by homogeneous material with an effective refractive index lower than the core, the core is completely surrounded by the cladding. The exterior matrix material and the core are then no longer directly connected. Nevertheless the width of the "effective cladding" is finite, and hence tunneling losses are unavoidable. Regardless of the approach one uses to explain guidance in MOFs, as long as guidance is due to a finite number of layers of holes, leakage from the core to the outer matrix material is unavoidable. We will call the losses due to the finite extent of the cladding confinement losses, or geometric losses.

$$\text{Confinement Loss, } L_c = \frac{40}{\text{Im}(n_{eff})} = 8.686K_0 \text{Im}(n_{eff}) \text{ [dB/m]} \quad (2.11)$$

# Chapter 3

---

## Structural Design

### 3.1 Introduction

For our research purpose we designed varieties model of PCF where cladding consists of five rings of air holes in different shape except triangular shape and a solid core which is shown in various Figure. Air hole diameter is represented as ( $d$ ) and the distance between two air holes known as pitch is represented as ( $\Lambda$ ) respectively. As we know, all light does not always go through the core of the fiber and some light might reflect and create a distortion, in order to minimize distortion we use perfectly matched layer (PML) outside the cladding so that it can absorb the loss light and not reflect to create distortion. In our research we changed the value of pitch and the diameter of air hole to see the change in confinement loss (dB).

### 3.2 Design

#### 3.2.1 Hexagonal Shape core with 2 core ring with $d/\Lambda = 0.575$

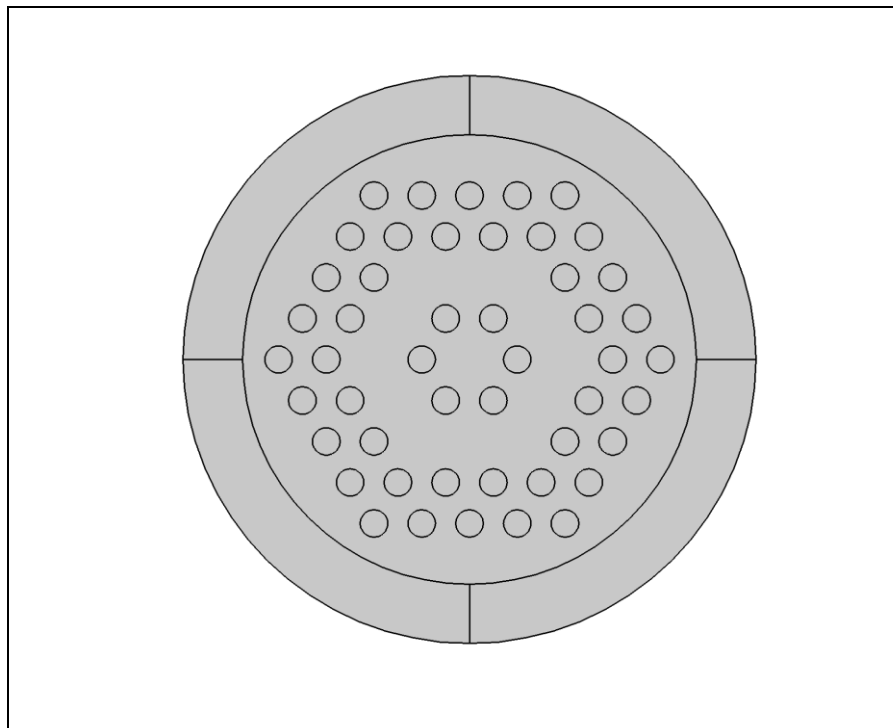

Figure 3.1: Hexagonal Shape core with 2 core ring with  $d/\Lambda = 0.575$

### 3.2.2 Hexagonal Shape core with 2 core ring with $d/\Lambda = 0.572$

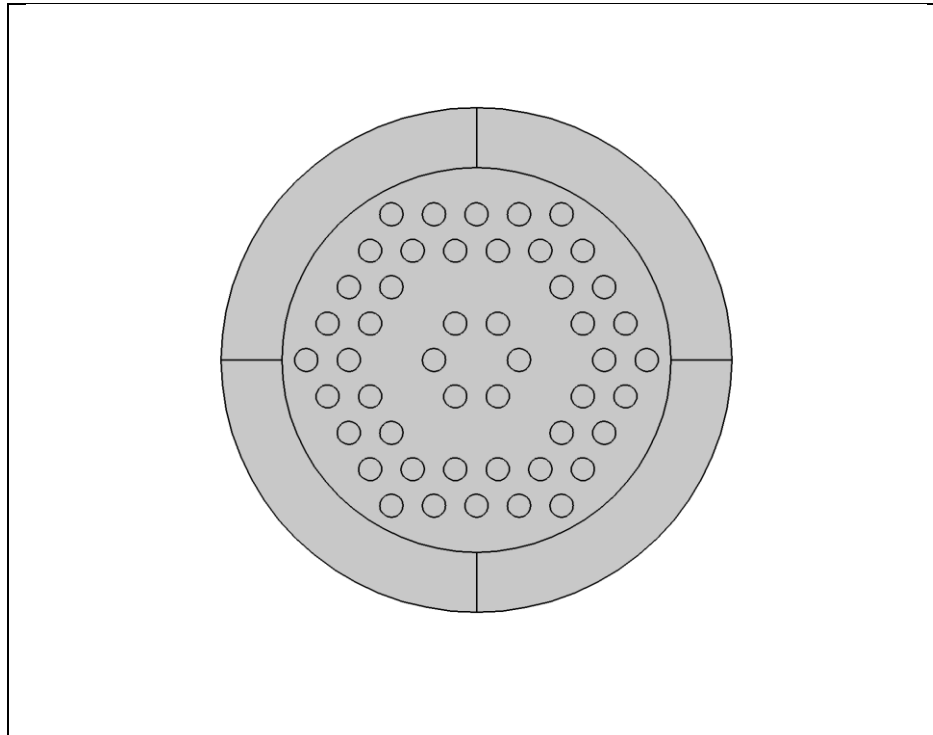

Figure 3.2: Hexagonal Shape core with 2 core ring with  $d/\Lambda = 0.572$

### 3.2.3 Hexagonal Shape with 1 core with $d/\Lambda = 0.79$

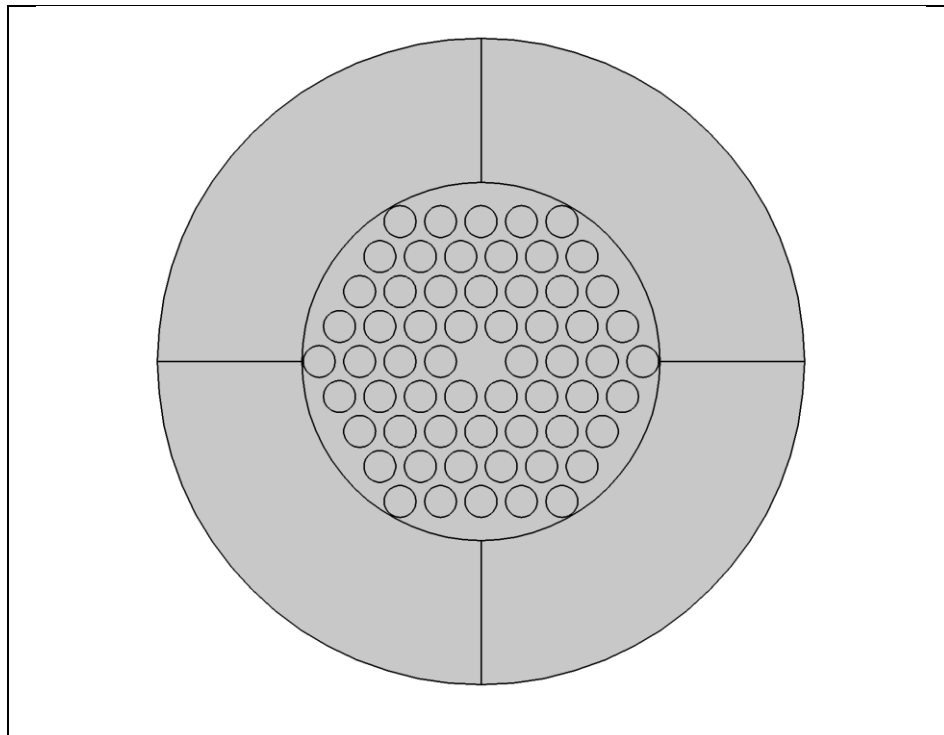

Figure 3.3: Hexagonal Shape with 1 core with  $d/\Lambda = 0.79$



### 3.2.4 Triangular Shape

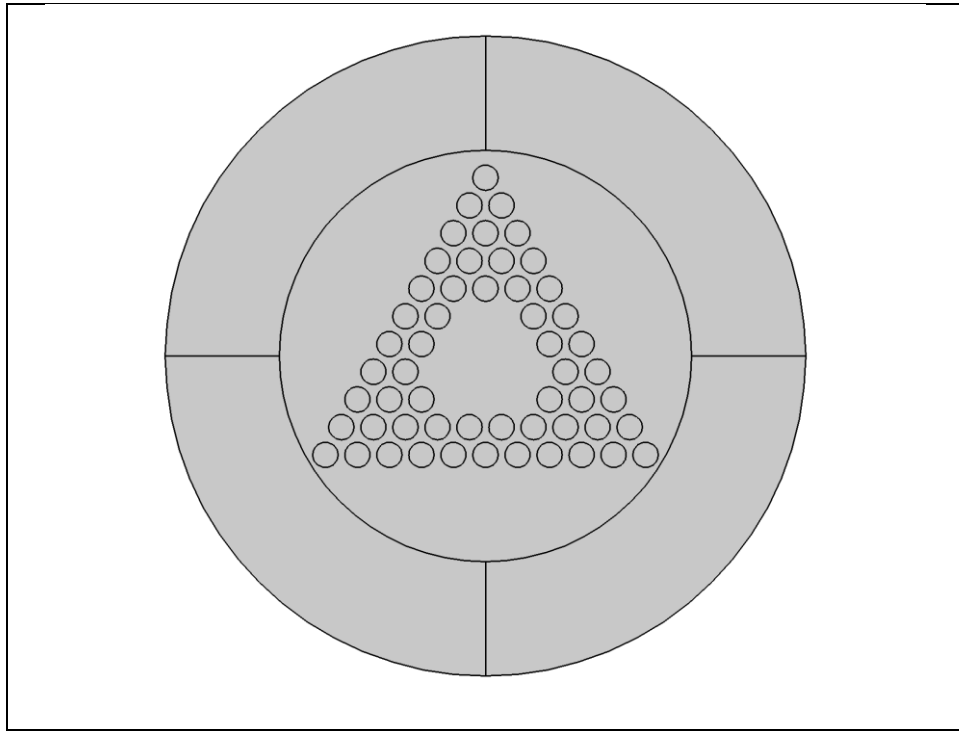

Figure 3.4: Triangular Shape

### 3.2.5 Elliptical Shape

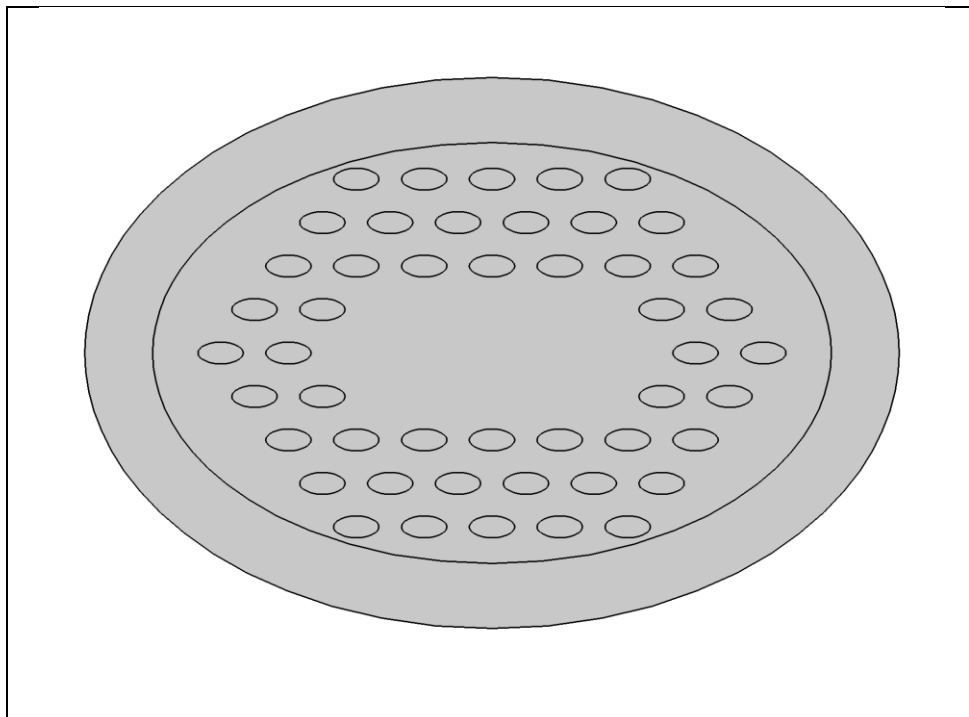

Figure 3.5: Elliptical Shape

# Chapter 4

## Simulated Result

### 4.1 Introduction

Comsol multiphysics 4.3b is used as a simulation tool with anisotropic perfectly matched layer (PML) boundary condition for designing and simulating photonic crystal fiber (PCF). It is considered the most efficient boundary condition for the PCF simulation. We have designed varieties model of photonic crystal fiber using Comsol which is described in before. In this case, we have changed different parameters-diameter of air hole  $d$  and pitch  $\Lambda$  to observe the effects of confinement loss. We have achieved the imaginary part of effective mode index after simulation which is then used to calculate confinement loss. Using the imaginary part of the effective mode index is used to calculate the confinement loss of PCF.

### 4.2 Result

#### 4.2.1 Hexagonal Shape core with 2 core ring with $d/\Lambda = 0.575$

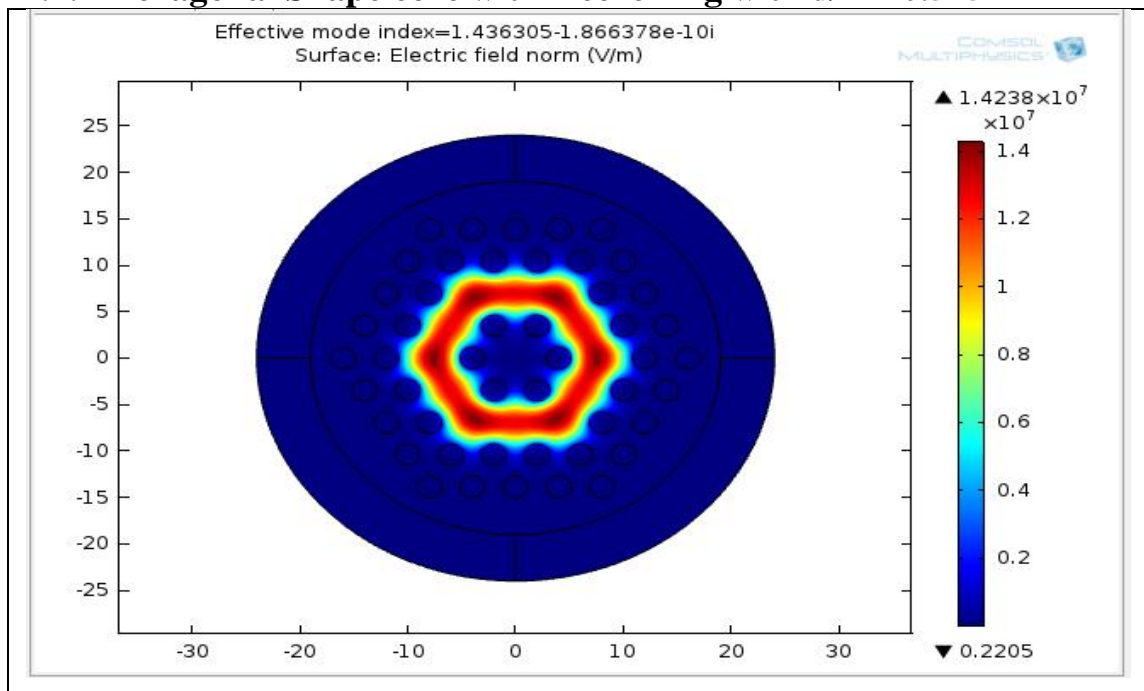

Figure 4.1: Effective mode index of Hexagonal Shape core with 2 core ring with  $d/\Lambda = 0.575$

#### 4.2.2 Hexagonal Shape core with 2 core ring with $d/\Lambda = 0.572$

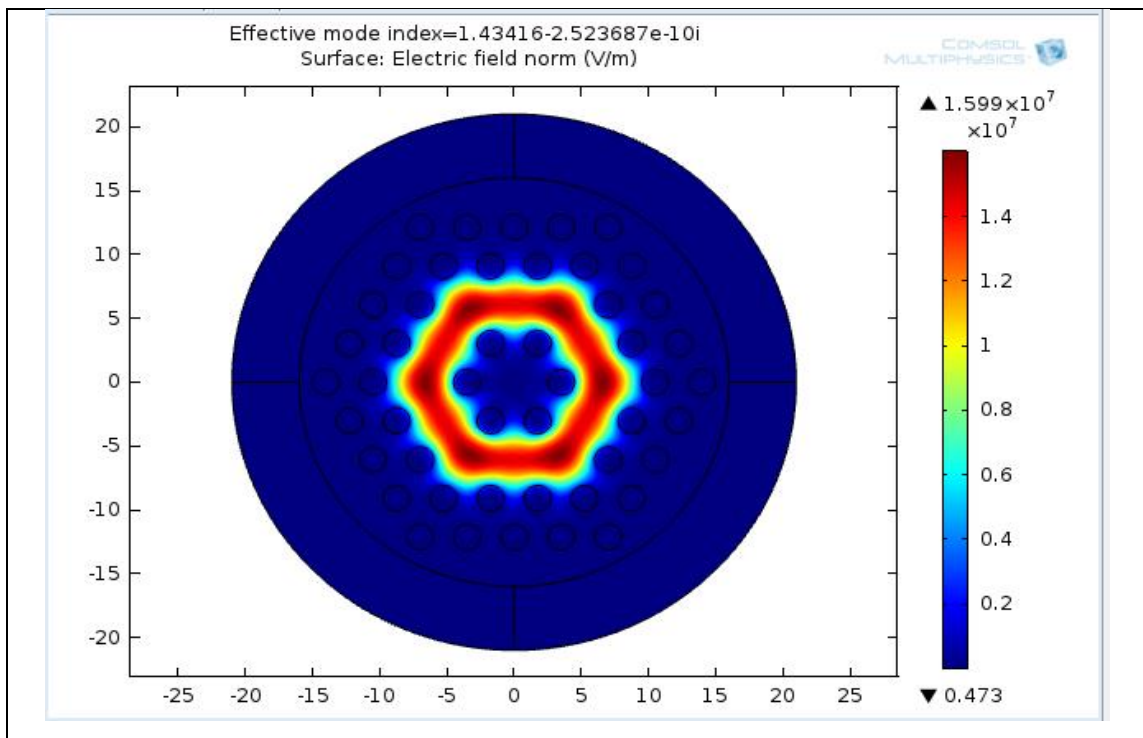

Figure 4.2: Effective mode index of Hexagonal Shape core with 2 core ring with  $d/\Lambda = 0.572$

#### 4.2.3 Hexagonal Shape with 1 core with $d/\Lambda = 0.79$

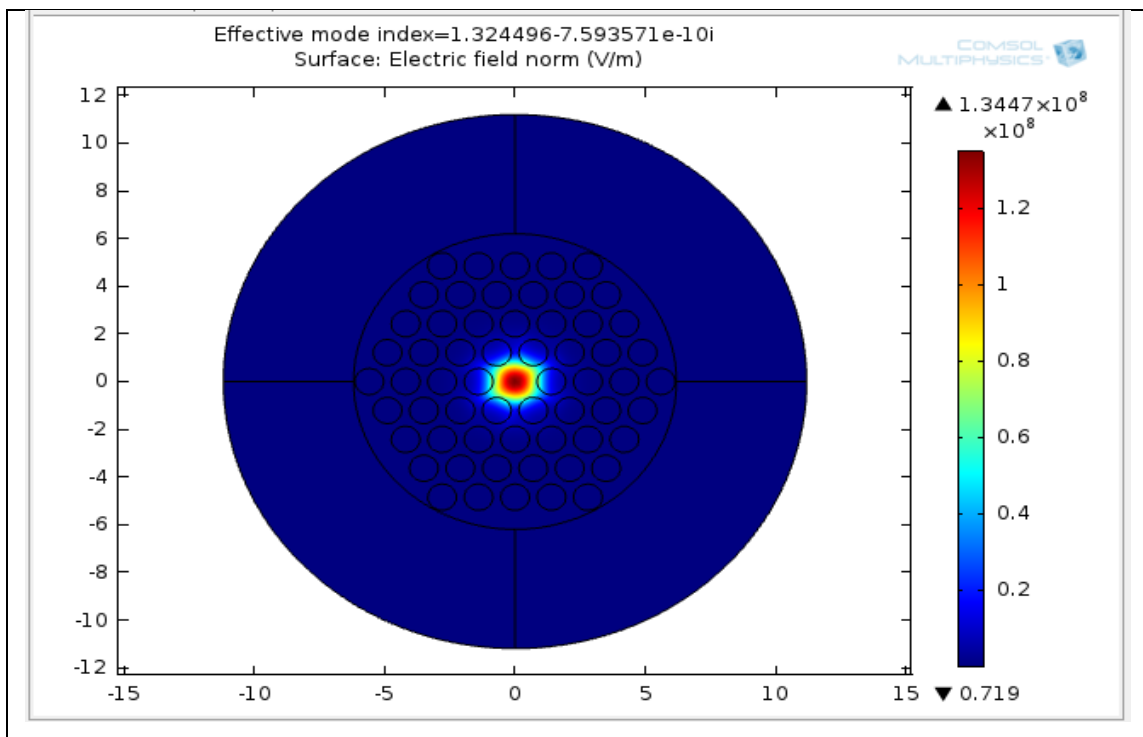

Figure 4.3: Effective mode index of Hexagonal Shape with 1 core with  $d/\Lambda = 0.79$

#### 4.2.14 Triangular Shape

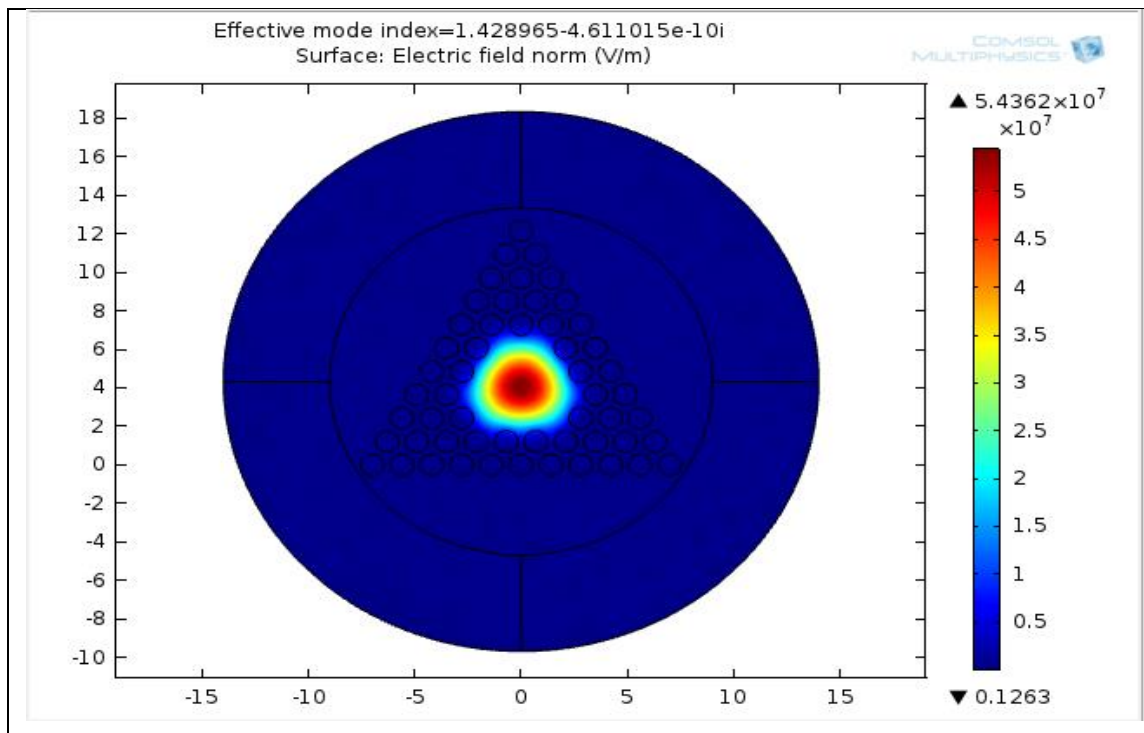

Figure 4.4: Effective mode index of Triangular Shape

#### 4.2.5 Elliptical Shape

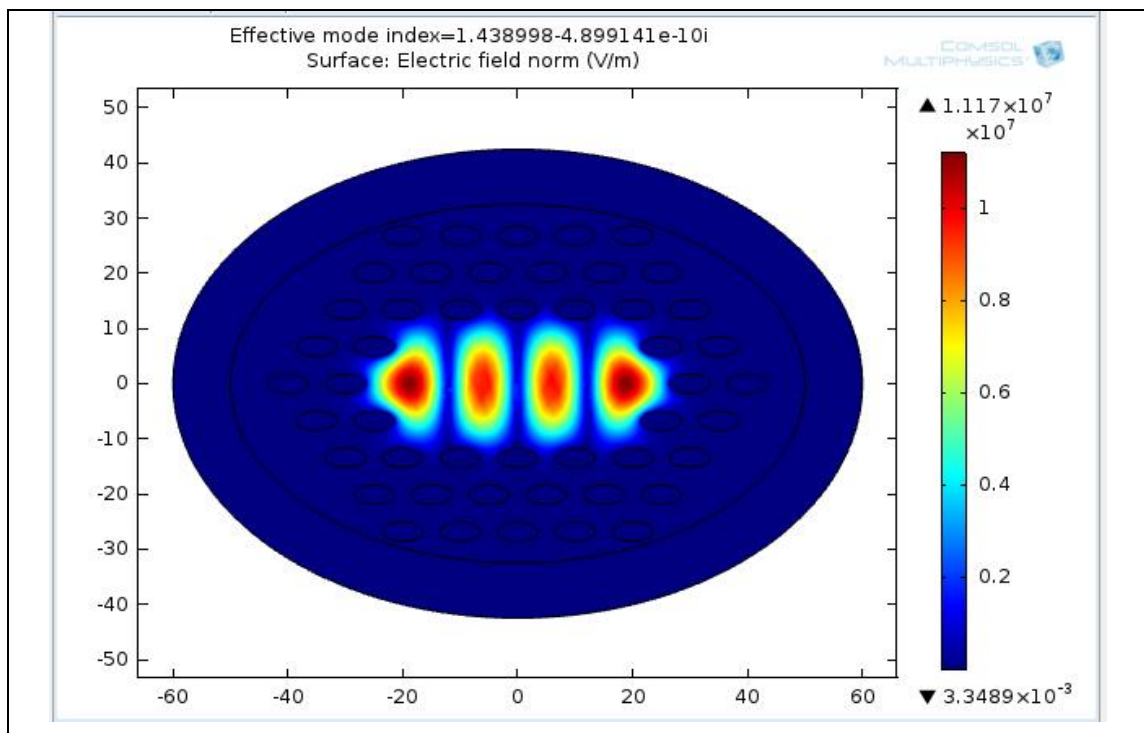

Figure 4.5: Effective mode index of Elliptical Shape

# Chapter 5

---

## Conclusion & Discussion

### 5.1 Discussion

In this thesis, we have proposed varieties design of photonic crystal fiber (PCF). Our approach was to achieve confinement loss. In order to do so we have changed different parameters such as air hole diameter and pitch to observe it. From our research we have concluded that confinement loss varies with the imaginary part of the effective index along with the wavelength. So, we get different confinement loss using the equation of confinement loss. After calculating the result we keep the best five structures. Those are 0.007 dB/m, 0.009 dB/m, 0.015 dB/m, 0.016 dB/m, 0.023 dB/m. We choose the best value that is 0.007dB/m, and it comes from the Hexagonal Shape core with 2 core ring with  $d/\Lambda = 0.575$ . Where we use the ratio of  $d/\Lambda = 0.575$ , wavelength,  $\lambda = 1550$  nm. If we use this in the LASER communication then we get the maximum efficiency.

### 5.2 Conclusion

In this thesis, we have proposed varieties design of photonic crystal fiber (PCF) with five rings of air hole except Triangular shape. Our approach was to achieve minimum confinement loss, which is used for optical communication system. In order to do so we have changed different parameters such as air hole diameter and pitch and observed the variation of different properties such as effective mode index, confinement loss. From our research we have concluded that confinement loss varies with the wavelength. We have noticed that the confinement loss depends on the diameter of the air hole  $d$  as well as on the pitch  $\Lambda$ . We have seen as we increase the diameter of the air hole keeping the pitch constant the confinement loss decreases. Moreover, pitch is varied keeping the diameter of the air hole constant to see the confinement loss. It is seen that as we increase the value of pitch, the confinement loss also increases. In future we will work on the basis of Hexagonal Shape core with 2 core ring with  $d/\Lambda = 0.575$ . Where we use the ratio of  $d/\Lambda = 0.575$  because of we get the low confinement loss here and we implemented it in various types of communications system.

# References

---

- [1] J. D. Joannopoulos, S G. Johnson, J. Winn, R. Meade, Photonic Crystals, “Molding the Flow of Light”, Princeton University Press” New Jersey, 2008.
- [2] AMÉLIE TÊTU, “Silicon-based components: 2D photonic crystal components and semiconductor nanocrystals”, Interdisciplinary Nanoscience Center (iNANO) and Department of physics and Astronomy, University of Aarhus, Denmark, PhD thesis, 2007.
- [3] Bahaa E.A. Saleh ,Malvin Carl Teich, “Fundamentals of Photonics”, John Wiley & Sons Inc.
- [4] Mark Curran and Brian Shirk , “Basics of Fiber Optics”.
- [5] Jayant Kapatker, “UNDERSTANDING FIBRE OPTICS”.
- [6] <https://www.google.es/search?q=photonic+crystal+fiber>
- [7] Dilshad-Uz-Zaman, Mir Md. Tanvir Nur, “Large Mode Area Hexagonal Photonic Crystal Fiber”
- [8] <https://www.tyndall.ie/content/what-are-photonic-systems>
- [9] <https://photonics3498.wordpress.com/what-is-photonics/>
- [10] <http://en.wikipedia.org/wiki/Photonics>
- [11] N Prasad, “Nanophotonics”, 2004 Wiley 415P
- [12] Lili Peng, “Absorption and emission properties of photonic crystals and metamaterials”, UMI Number: 1446140.
- [13] John D. Joannopoulos, Steven G. Johnson, Joshua N. Winn,Robert D. Meade, “Photonic Crystals- Molding the flow of light”, Second Edition, Princeton University Press, 2008.
- [14] FATİH GİRİŞKEN, “PHOTONIC CRYSTALS”, İZMİR INSTITUTE OF TECHNOLOGY 2008.
- [15] Alessandro Massaro, “Photonic Crystals – Introduction, Applications and Theory”, Croatia, 2012.
- [16] John M. Senior, “Optical Fiber Communications” 3<sup>RD</sup> ED. , Dorling Kindersley, India, 2010.
- [17] X.-C. Zhang, Jingzhou Xu, “Introduction to THz Wave Photonics”, Springer Science + Business Media, LLC ,2010.
- [18] OVEJABIENNEGRA, “ Characterization of Optical Fibers”, APRIL 19, 2009.

- [19] R. B. Wehrspohn, H.-S. Kitzerow, and K. Busch, "Nanophotonic Materials: Photonic Crystals, Plasmonics, and Metamaterials", WILEY-VCH Verlag GmbH & Co. KGaA, Weinheim, 2008.
- [20] Frederic Zolla, Gilles Renversez, Andre Nicolet, Boris Kuhlmeiy, Sebastien Guenneau, Didier Felbacq, "FOUNDATIONS of PHOTONIC CRYSTAL FIBRES", Imperial College Press, 2005.