



INTERNSHIP REPORT

ON

ASHUGANJ POWER STATION COMPANY LIMITED

By

Khandker Taufiq Imran ID: 2008-2-80-057

Md. Mizanur Rahman ID: 2007-02-80-010

Syed Rumman Hossain ID: 2007-2-80-021

Submitted to the

Department of Electrical and Electronic Engineering

Faculty of Sciences and Engineering

East West University

In partial fulfillment of the requirements for the degree of
Bachelor of Science in Electrical and Electronic Engineering

(B.Sc. in EEE)

Spring, 2012

INTERNSHIP REPORT
ON
ASHUGANJ POWER STATION COMPANY LIMITED

By

Khandker Taufiq Imran ID: 2008-2-80-057
Md. Mizanur Rahman ID: 2007-02-80-010
Syed Rumman Hossain ID: 2007-2-80-021

Submitted to the
Department of Electrical and Electronic Engineering
Faculty of Sciences and Engineering

East West University

In partial fulfillment of the requirements for the degree of
Bachelor of Science in Electrical and Electronic Engineering
(B.Sc. in EEE)

Spring, 2012

Approved By:

Academic Advisor

Dr Mohammad Mojammel Al Hakim

Academic Advisor

Fakir Mashuque Alamgir

Academic Advisor

S. M. Shahriar Rashid

Department Chairperson

Dr. Khairul Alam

Approval Letter

ASHUGANJ POWER STATION COMPANY LTD. (APSCL)
(An Enterprise of Bangladesh Power Development Board)



**CIRIFICATION FOR INDUSTRIAL ATTACHMENT
TRAINING PROGRAMME**

Certified that Khandker Taufiq Imran, Student. ID No- 2008-2-80-057 of Electrical & Electronic Engineering Département of East- West University, Dhaka, has participated the Industrial Attachment Training Program from 26-12-2011 to 11-01-2012 and successfully completed the course.

*Jehun -
11-01-2012*

**Course Coordinator
&
Manager (HRD)
Ashuganj Power Station Company Ltd.
Ashuganj, B-Baria.**

ASHUGANJ POWER STATION COMPANY LTD. (APSCL)
(An Enterprise of Bangladesh Power Development Board)



**CIRIFICATION FOR INDUSTRIAL ATTACHMENT
TRAINING PROGRAMME**

Certified that Syed Rumman Hossain, Student. ID No- 2007-2-80-021 of Electrical & Electronic Engineering Département of East- West University, Dhaka, has participated the Industrial Attachment Training Program from 26-12-2011 to 11-01-2012 and successfully completed the course.

*Rumman -
11-01-2012*

**Course Coordinator
&
Manager (HRD)
Ashuganj Power Station Company Ltd.
Ashuganj, B-Baria.**

ASHUGANJ POWER STATION COMPANY LTD. (APSCCL)
(An Enterprise of Bangladesh Power Development Board)



**CIRIFICATION FOR INDUSTRIAL ATTACHMENT
TRAINING PROGRAMME**

Certified that Md. Mizanur Rahman, Student. ID No- 2007-2-80-010 of Electrical & Electronic Engineering Département of East- West University, Dhaka, has participated the Industrial Attachment Training Program from 26-12-2011 to 11-01-2012 and successfully completed the course.

[Signature]
11-01-2012

**Course Coordinator
&
Manager (HRD)
Ashuganj Power Station Company Ltd.
Ashuganj, B-Baria.**

Acknowledgment

In the preparation of this internship report, we acknowledge the encouragement and assistance given by a number of people from Ashugonj power station com. Ltd. We are grateful to Engr. Md. Nurul Alam, Managing Director APSCCL, Engr. Achinta Kumar Sarker, DGM (Mechanical), Engr. Md. Azizur Rahman, Assistant engineer(CCPP), Engr. Md. Anwar Hossain, Manager(operation), Engr. Md. Kamruzzaman, Senior Engr.(Generation), Engr. Noor Mohammad, Manager(Substation) and also the Manager of I&C Engr. Bikash Rangan Roy for their valuable suggestions and assurance.

Besides, we would also like to mention the name of Dr. Khairul Alam, Chairperson and Professor of the Department of Electrical & Electronic Engineering and all of our teachers for their support. We also like to mention the name of our former Chairperson professor Dr. Anisul Haque for his support.

We would like to express our gratitude to our advisor Mohammad Mojammel Al Hakim, Associate Professor; S. M. Shahriar Rashid, Lecturer; Fakir Mashuque Alamgir, Lecturer; Department of Electrical & Electronic Engineering, East West University, Bangladesh, for sharing their ideas and interests with us about our study. Their contribution boosted our confidence and helped us finish our study on time.

Lastly, we want to show our gratefulness to all the respondents who spared their precious time in answering our questionnaires.

Executive Summary

Availability of power is one of the important ingredients for industrial growth. Increasing automation of Bangladeshi industries has created huge demand of power in Bangladesh. The Government of Bangladesh (GOB) is committed to provide affordable and reliable electricity to all citizens by 2020. However, among the country's 138 million people, only 40 percent has access to electricity of 136KWh. The power sector includes the generation, transmission, and distribution of electricity among different holdings including residential, commercial, business and service sectors. Bangladesh's installed electric generation capacity was 4.7 GW in 2009. In this field Ashuganj power station Company limited played an important role in generation of power from 1964. Now it is the second largest power company in Bangladesh. The company is taken numerous development program for increase its generation which is the demand of time.

Through our internship at APSCL we have gathered a tremendous knowledge on power sector including power generation, Transmission and power system protection. Through this internship we get a great opportunity to relate our theoretical knowledge with the practical knowledge whatever we have gained with our university academic courses. We have given a brief description of our experiences on electricity production, distribution and transmission system in Bangladesh in our intern report. We also added history and future plans of APSCL. Discussion of different generating unit and there fuel system is briefly discussed. We added rating and specifications of generators and substation equipments. Different type of transformers is used. In substation Isolator, feeder, breakers are the main equipment. Different type of switchgear and control rooms is used for Protection purposes and also for controlling.

In APSCL we visited the whole power plant and achieved a clear idea about its generation, controlling and maintenance process. We visit both steam turbine and CCPP of APSCL. We monitor the gas supply from Titas gas field and air collection process. In steam turbine section we visited the water treatment plant and understand the presses of water purification. We also go to different control rooms. Visiting the substation of APSCL was a great achievement for us. In there, we saw how power is connected to the greed. Protection system of whole power station gives us a clear idea about its importance. So we can say our industrial attachment to Ashuganj power station company Ltd will be a lifetime asset for us.

Training Schedule

Training Schedule of Khandker Taufiq Imran, Md. Mizanur Rahman & Syed Rumman Hossain:

| Date | Division | Time | Working Hour | Mentor |
|-------------------|-------------------------------------------------|-------------|---------------------|------------------------------|
| 26-12-2011 | Total Plant Overview (Control meters) | 8am to 4pm | 7 Hour | Engr.Achinta Kumer Sarker |
| 27-12-2011 | Instrument and Control (Control room) | 8am to 4pm | 7 Hour | Engr.Bikash Ranjan Roy |
| 28-12-2011 | Instrument and Control (Control Valves) | 8am to 4pm | 7 Hour | Engr.Bikash Ranjan Roy |
| 29-12-2011 | Combine Cycle Power Plant (Gas turbine-1) | 8am to 4pm | 7 Hour | Engr.Azizur Rahman |
| 31-12-2011 | Combine Cycle Power Plant (Gas turbine-2) | 8am to 4pm | 7 Hour | Engr.Azizur Rahman |
| 01-01-2012 | Combine Cycle Power Plant (Steam Turbine) | 8am to 4pm | 7 Hour | Engr.Azizur Rahman |
| 02-01-2012 | Sub-Station (Distribution profile) | 8am to 4pm | 7 Hour | Engr.Noor Mohammad |
| 03-01-2012 | Sub-Station (Feeder equipment's) | 8am to 4pm | 7 Hour | Engr.Noor Mohammad |
| 04-01-2012 | Sub-Station (Protection equipments) | 8am to 4pm | 7 Hour | Engr.Noor Mohammad |
| 05-01-2012 | Generator (Structure) | 8am to 4pm | 7 Hour | Engr. Md.Kamruzzaman |
| 07-01-2012 | Generator (synchronization) | 8am to 4pm | 7 Hour | Engr. Md.Kamruzzaman |
| 08-01-2012 | Generator (Protection) | 8am to 4pm | 7 Hour | Engr. Md.Kamruzzaman |
| 09-01-2012 | Operation (Water and steam cycle) | 8am to 4pm | 7 Hour | Engr.Md.Anwar Hossain |
| 10-01-2012 | Operation (Combustion system) | 8am to 4pm | 7 Hour | Engr.Md.Anwar Hossain |
| 11-01-2012 | Operation (Bypass system) | 8am to 4pm | 7 Hour | Engr.Md.Anwar Hossain |
| | | | Total= | |
| | | | 105 hrs | |

TABLE OF CONTENTS

Chapter 1..... 17

1 Introduction: 17

 1.1 Company Profile: 17

 1.2 Objective of the Internship:..... 19

 1.3 Scope and Methodology: 20

Chapter 2..... 21

2 Generation and Future Plan..... 21

 2.1 Introduction:..... 21

 2.2 Power Generation Process in APSCL: 21

 2.3 Generator of Gas Turbine and Steam Turbine Unit:..... 22

 2.3.1 Description of AC Generator in APSCL: 22

 2.3.2 Synchronization with the Power Grid: 25

 2.4 Steam Turbine Power Plant: 27

 2.4.1 Steam Turbine:..... 28

 2.4.2 Burner: 30

 2.4.3 Boiler Used in APSCL: 31

 2.4.4 Flue Gas:..... 32

 2.4.5 Forced Draft Fan or FD Fan: 33

 2.4.6 Super Heater or SH: 33

 2.4.7 Re-heater or RH: 34

 2.4.8 Feed Water Heater:..... 35

 2.4.9 Chimney: 37

 2.4.10 Economizer: 37

 2.4.11 Water Treatment Plant: 37

 2.4.12 Deaerator:..... 38

 2.5 Combined Cycle Power Plant Section in APSCL:..... 39

 2.5.1 GT or Gas Turbine Section in CCGT of APSCL: 40

 2.5.2 ST or Steam Turbine Section of CCGT in APSCL:..... 42

 2.6 Gas Engine Power Plant in APSCL: 43

 2.7 Control Room of Generator: 45

 2.8 Future Projects of APSCL to Increase Generation: 47

| | | |
|----------------|-----------------------------------------|----|
| 2.9 | Conclusion: | 48 |
| Chapter 3..... | | 49 |
| 3 | Controlling Valve: | 49 |
| 3.1 | Introduction: | 49 |
| 3.2 | Gas Pressure Reducing Valve: | 49 |
| 3.3 | FD Fan Air Flow Control Valve: | 50 |
| 3.4 | Water flow Controller: | 51 |
| 3.5 | Super Heater Safety Valve: | 51 |
| 3.6 | Conclusion: | 52 |
| Chapter 4..... | | 53 |
| 4 | Protection Systems of Plant: | 53 |
| 4.1 | Introduction: | 53 |
| 4.2 | Generator Protection: | 53 |
| 4.2.1 | Over Current Protection: | 54 |
| 4.2.2 | Over Voltage Protection: | 55 |
| 4.2.3 | Reverse Power Protection: | 55 |
| 4.2.4 | Under Frequency Protection: | 56 |
| 4.2.5 | Negative Phase Sequence Protection: | 56 |
| 4.2.6 | Stator Earth Fault: | 57 |
| 4.2.7 | Rotor Earth Fault Protection: | 58 |
| 4.2.8 | Winding Differential Protection: | 58 |
| 4.3 | Cooling System of Generator: | 59 |
| 4.3.1 | Air Cooling: | 59 |
| 4.3.2 | Hydrogen Cooling: | 60 |
| 4.4 | Turbine Protection: | 60 |
| 4.4.1 | Shaft and Bearing Vibration Protection: | 61 |
| 4.4.2 | Lube Oil Pressure Protection: | 61 |
| 4.4.3 | Shaft Temperature Protection: | 62 |
| 4.4.4 | Over Speed Protection: | 62 |
| 4.5 | Boiler Protection: | 62 |
| 4.5.1 | Drum Level High & Low Protection: | 63 |
| 4.5.2 | Furnace Temperature Protection: | 63 |

| | | |
|-----------|--------------------------------------------------------------------|----|
| 4.5.3 | Steam Pressure Protection: | 63 |
| 4.5.4 | Flue gas Damper Protection:..... | 64 |
| 4.6 | Transformer Protection: | 65 |
| 4.6.1 | Short-circuit and Over Current Protection:..... | 65 |
| 4.6.2 | Oil Temperature Indicator (OTI): | 66 |
| 4.6.3 | Pressure Relay Device (PRD): | 67 |
| 4.7 | Cooling System of Transformer:..... | 67 |
| 4.7.1 | Oil Filled Self Cooling:..... | 67 |
| 4.7.2 | Forced Air Cooling:..... | 68 |
| 4.8 | Bas-bar Protection:..... | 69 |
| 4.9 | Transmission Line Protection: | 69 |
| 4.9.1 | Distance Protection:..... | 69 |
| 4.9.2 | Directional Earth Fault Protection: | 70 |
| 4.10 | Danger switch: | 71 |
| 4.11 | Protection Control Room: | 71 |
| 4.12 | Conclusion: | 72 |
| Chapter 5 | | 73 |
| 5 | SUBSTATION..... | 73 |
| 5.1 | Introduction:..... | 73 |
| 5.2 | Overview of Power Generation, Transmission and Distribution: | 73 |
| 5.3 | Voltage Classes of APSCL: | 74 |
| 5.4 | Grid Voltage and Distribution Voltage of APSCL: | 74 |
| 5.5 | Distribution Voltage: | 75 |
| 5.6 | Generating Profile of APSCL: | 75 |
| 5.7 | System Components: | 76 |
| 5.7.1 | Transformer: | 76 |
| 5.7.2 | Isolator: | 83 |
| 5.7.3 | Power Circuit Breaker: | 84 |
| 5.7.4 | Earthling Switch: | 87 |
| 5.7.5 | Lightning Arrester: | 88 |
| 5.7.6 | Relay:..... | 89 |
| 5.7.7 | Automatic Circuit Recloser:..... | 91 |

| | | |
|-------------|-----------------------------------------------------------|-----|
| 5.7.8 | Power Capacitors: | 91 |
| 5.7.9 | Bus Bar: | 91 |
| 5.7.10 | Insulator: | 92 |
| 5.7.11 | Transmission Line:..... | 93 |
| 5.7.12 | Wave Trap: | 95 |
| 5.8 | Single Line Diagram: | 96 |
| 5.9 | DC Battery and Battery Charger Room: | 97 |
| 5.10 | Control Room: | 97 |
| 5.11 | Cables:..... | 98 |
| 5.12 | Brief Discussion of a Single Feeder:..... | 98 |
| 5.13 | Flow Diagram of a Single Feeder of APSCL Substation:..... | 101 |
| 5.14 | Conclusion: | 102 |
| Chapter 6 | | 103 |
| 6 | Problems and Recommendations:..... | 103 |
| Chapter 7 | | 104 |
| 7 | Conclusion..... | 104 |
| Chapter-8 | | 105 |
| 8 | References: | 105 |
| Glossaries: | | 106 |

LIST OF FIGURES

| | |
|---------------------------------------------------------------------------------------|----|
| Figure 2.1: 150 MW AC generator of unit 3 | 22 |
| Figure 2.2: DC Exciter used in 150 MW generator of unit 3. | 24 |
| Figure 2.3: Jacking oil pump in 36.7 MW generator of CCPP..... | 25 |
| Figure 2.4: Synchroscope in the control room of 150 MW unit 3..... | 26 |
| Figure 2.5: Water and steam cycle of 150 MW & 15.75 KV unit 5..... | 27 |
| Figure 2.6: LP turbine used in 150 MW & 15.75 KV of APSCL..... | 29 |
| Figure 2.7: Burner used in 150 MW & 15.75 KV of APSCL. | 30 |
| Figure 2.8: Water tube boiler used in all 150 MW & 15.75 KV generating unit. | 31 |
| Figure 2.9: Boiler and flue gas system of 150 MW & 15.75 KV unit 5..... | 32 |
| Figure 2.10: FD fan for 150 MW & 15.75 KV unit 4..... | 33 |
| Figure 2.11: Super heater cycle in 150 MW & 15.75 KV unit 5..... | 33 |
| Figure 2.12: Re-heater system in 150 MW & 15.75 KV unit 5..... | 35 |
| Figure 2.13: Low pressure heater in 150 MW & 15.75 KV unit 4 at APSCL..... | 36 |
| Figure 2.14: Chimney in 64 MW & 11 KV units 1. | 37 |
| Figure 2.15: Water treatment plant in APSCL..... | 38 |
| Figure 2.16: Deaerator in 150 MW & 15.75 KV unit 3 at APSCL. | 39 |
| Figure 2.17: Diesel engine in 56 MW & 13.8 KV GT of CCPP. | 41 |
| Figure 2.18: Condenser in steam turbine of 34 MW & 13.8 KV in CCPP..... | 43 |
| Figure 2.19: 3332 KW, GE J 620 GS-F101 Gas engine power generators used in APSCL..... | 44 |
| Figure 2.20: Analog monitoring parts of 64 MW & 11 KV unit 1. | 45 |
| Figure 2.21: Analog control system in a control room of 64 MW & 11 KV unit 1. | 45 |
| Figure 2.22: PLC controlled control room in 150 MW & 15.75 KV unit 4. | 46 |
| Figure 2.23: Software based control system in 64 MW & 11 KV unit 5..... | 46 |
| Figure 3.1: Gas pressure reducing valve..... | 50 |
| Figure 3.2: Gas filter inlet shut off valve..... | 50 |
| Figure 3.3: FD fan air flow control valve. | 51 |
| Figure 3.4: Water flow control valve..... | 51 |
| Figure 3.5: Super heater safety valve..... | 52 |
| Figure 4.1: Over current protection and alarming relay. | 54 |
| Figure 4.2: Reverse power protection. | 55 |
| Figure 4.3: Under frequency relay. | 56 |
| Figure 4.4: Negative phase sequence relay..... | 57 |
| Figure 4.5: Stator earth fault protection..... | 57 |
| Figure 4.6: Generator Differential Relay..... | 58 |
| Figure 4.7: Hydrogen supply station..... | 60 |
| Figure 4.8: Shaft vibration sensor for unit 5 steam turbine connects with shaft..... | 61 |

| | |
|--------------------------------------------------------------------------------|----|
| Figure 4.9: Lube oil pressure control switch. | 61 |
| Figure 4.10: Thermocouple for measure shaft temperature. | 62 |
| Figure 4.11: Boiler drum level indicator. | 63 |
| Figure 4.12: Steam pressure safety valve of boiler. | 64 |
| Figure 4.13: Flue gas damper of boiler. | 64 |
| Figure 4.14: Differential relay. | 66 |
| Figure 4.15: Buchholz relay. | 66 |
| Figure 4.16: Transformer radiator for oil filled safe cooling. | 68 |
| Figure 4.17: Forced air cooling system of transformer. | 68 |
| Figure 4.18: Transmission line distance protection. | 70 |
| Figure 4.19: Directional earth fault protection. | 70 |
| Figure 4.20: Danger switch. | 71 |
| Figure 4.21: Control room at APSCL. | 72 |
| Figure 5.1: Distribution asset in national network. | 74 |
| Figure 5.2: Tap changing power transformer. | 77 |
| Figure 5.3: Radiator of a power transformer. | 78 |
| Figure 5.4: Breather of a power transformer. | 78 |
| Figure 5.5: Bushing of power transformer. | 79 |
| Figure 5.6: Potential transformer with nameplate of the APSCL substation. | 79 |
| Figure 5.7: Current transformer with nameplate of the APSCL substation. | 81 |
| Figure 5.8: Single phase unit transformer. | 81 |
| Figure 5.9: Intermediate potential transformer. | 82 |
| Figure 5.10: Horizontal center break isolator from APSCL. | 84 |
| Figure 5.11: Minimum oil CB. | 85 |
| Figure 5.12: SF6 circuit breaker. | 87 |
| Figure 5.13: Earthling switch used in 132KV line. | 87 |
| Figure 5.14: Rod gap type lightning arrester of APSCL. | 88 |
| Figure 5.15: Horn type of lightning arrester. | 89 |
| Figure 5.16: 132KV double circuit bus bar. | 91 |
| Figure 5.17: Pin type insulator for 33KV line. | 92 |
| Figure 5.18: Suspension type insulator observed from APSCL substation. | 93 |
| Figure 5.19: High voltage double circuit transition line. | 94 |
| Figure 5.20: Pole structure of transmission line. | 94 |
| Figure 5.21: Wave trap used on APSCL substation. | 95 |
| Figure 5.22: Dc battery room of APSCL substation. | 97 |
| Figure 5.23: Rectifier used for battery charging purpose. | 98 |
| Figure 5.24: Conductors which contains 4000A current. | 99 |
| Figure 5.25: Primary bushing of a single phase unit transformer. | 99 |

| | |
|------------------------------------------------------------------------|-----|
| Figure 5.26: Output bushing of the single phase unit transformer. | 100 |
| Figure 5.27: Typical 230KV feeder for unit three. | 100 |
| Figure 5.28: 230KV Double circuit bus bar..... | 101 |

LIST OF TABLES

| | <u>Page</u> |
|-----------------------------------------------------------------------------------------------------|-------------|
| Table 1.1: Overview of 777 MW APSCL power station..... | 19 |
| Table 2.1 : Configuration of supper heater used in APSCL. | 34 |
| Table 2.2: Feed water temperature in APSCL | 35 |
| Table 2.3 : Description of CCPP (146MW) in APSCL | 39 |
| Table 2.4 : Description of gas engine power plant in APSCL..... | 44 |
| Table 2.5: Description of 225 MW plant. | 47 |
| Table 2.6: Description of proposed 450 MW CCPP..... | 47 |
| Table 2.7: Description of 450MW CCPP (north). | 48 |
| Table 4.1: Type & model number of relays which are used at APSCL for generators protection. | 59 |
| Table 5.1: Steam turbine generator. | 75 |
| Table 5.2: Combined cycle power plant. | 75 |
| Table 5.3: 132 kV Single phase outdoor type potential transformer. | 80 |
| Table 5.4: Insulters voltage level with its number of disk. | 93 |
| Table 5.5: : Different Cables Used at APSCL Substation. | 98 |

Chapter 1

1 Introduction:

Ashugonj power station is the second largest power station in Bangladesh. The present total power generation capacity of its 9 units is 674 MW. As a part of the power sector development and reform program of the government of Bangladesh, Ashugonj power station company Ltd. has been incorporated under the companies' act 1994 on 28 June 2000. Electricity generated in this power station is supplied to the grid & distributed throughout the whole country. This power station generated more than 10% of the total demand of the country. In this power station natural gas from Titas gas transmission & distribution company Ltd. is used as fuel. Meghna River is used as the source of water for the steam in this plant. Huge water from the discharge channels are used for irrigation in dry section.

In this chapter, there will be a brief discussion on the history and specification of Ashugonj power station. Company profile will be discussed in the 1st part. We will discuss the objectives of this internship. And in the end there will be a discussion on Scope and Methodology.

1.1 Company Profile:

To know about Ashugonj power station we need to know about its past and its present status. In the beginning Ashugonj power station was not a company, it was 100% government. To improve its productivity government decided to make it a company. After it became a company its productivity increases. Company profile is given below for a clear idea.

Company Profile

Name of the Company: Ashugonj Power Station Company Ltd.

Date of Incorporation: 28 June 2000.

Registration No: C-40630 (2328)/2000 dt. 28.06.2000;

Location: 90 km North-East of Dhaka on the left bank of the river Meghna.

Land: 311.22 Acres

Installed Capacity: 724 MW

Total number of plants: 4

Total Number of Units: 9

- a) Plant 1: Thermal Power Plant (TPP)
 - i. Two Steam Units of 64MW- Unit # 1 & 2 each-commissioned in 1970.
- b) Plant 2: Combined Cycle Power Plant (CCPP)
 - i. Gas Turbine Units-GT1 and GT2 of capacity 56MW each-commissioned in 1982 and 1986 respectively.
 - ii. One Steam Turbine (ST) of capacity 34MW with waste heat recovery Boiler commissioned in 1984.
- c) Plant 3: Thermal Power Plant (TPP)
 - i. Unit # 3 of 150MW capacity was commissioned in 1986.
 - ii. Unit # 4 of 150MW capacity was commissioned in 1987.
 - iii. Unit # 5 of 150MW capacity was commissioned in 1988.
- d) Plant 4: Gas engine power plant
 - i. Number of unit: 16
 - ii. Unit # 1~16, each of them are 3332 KW was commissioned in 2011.
- e) Fuel used: Natural Gas Supplied by Titas Gas Transmission & Distribution Co. Ltd., Bangladesh.
- f) APSCL at a glance :

Table 1.1: Overview of 777 MW APSCL power station.

| | |
|----------------------------|-------------------------------------------------------------------------------------------------------------------|
| Corporate office | Ashugonj Power station company Ltd. Ashugonj, Brahmanbaria-3402 |
| Registration no | C-40630 (2328)/2000 |
| Date of incorporation | 28 June 2000 |
| Status | Public limited company |
| Business | Power generation |
| Number of generating units | 9(6 steamturbine+2 gas turbine+ 1gas turbine) |
| Installed capacity | 777 MW |
| Present de-rated capacity | 731 MW |
| Dependable Capacity | 624 MW |
| Authorized capital in taka | 150000000000 /- |
| Paid up capital in taka | 1000000 /- |
| Area of land | 263.55 Acres |
| Manpower as on 30.06.2011 | 525 (Regular employee) |
| Company website | www.apscl.com |
| E-mail | apscl@apscl.com , apsclbd@yahoo.com ; |

1.2 Objective of the Internship:

The primary objective of the internship was as follows:

“Monitoring, Evaluating and understanding of generation process, management process and also overall transiting and maintenance process of a power plant, which is a part of completing our requirement for Electrical and electronic engineering program.”

The secondary objectives were as follows:

- Understanding of corporate job pattern.

- Understanding of generation & substation system in a power plant.
- To have a practical idea about what we learn in Electrical and electronic engineering program at the university.
- To have an idea on how a company management should be operated.
- To have an idea, how power station can be controlled in different ways.
- The financial and social impact analysis of the projects on the areas near to the plant.

1.3 Scope and Methodology:

The goal of this Internship was to understand the practical operation of a power plant.

This report covered the following aspects:

- Power generation process
- Substation mechanism
- Protection skims in power station
- And also the future plan of this power station.

The information's that are used in this report is collected in different methods.

- The primary information was collected through direct interaction with APSCL engineers and employees. They also provide us some documents and diagrams from their offices.
- The secondary information's are collected from website of APSCL and using their annual report of 2011. Different website also provides us information's which are mentioned in reference part.

Chapter 2

2 Generation and Future Plan

2.1 Introduction:

Generation of maximum power in minimum cost is the main concern of a power generation plant. In nature, energy cannot be created or destroyed, but its form can change. In generating electricity, no new energy is created. Actually one form of energy is converted to another form. Depending on environment and fuel there is different type of power generating plant.

Whole generation part of Ashugonj power station com. Ltd will be discussed in this chapter. Discussion on different types of plant in APSCL will be emphasized. Steam turbine, gas turbine and CCPP will be discussed separately. Most of the discussion will be on the generating equipment, fuel, procedure etc. Different control system used in APSCL in the generation part will also be discussed. To improve generation capability APSCL is having some future plans, which will be discussed in this section also.

These sections are described by Engr.Achinta kumar sarkar, Engr.Azizur Rahman, Engr.Md. Kamruzzaman and Engr.Anwar Hossain in 26th ,29th ,31st December 2011 and 5th ,9th ,10th January 2012 from 8am to 4pm, 7 hours each day. In total we have completed 42 hours in those 6 days.

2.2 Power Generation Process in APSCL:

Ashugonj power station com. Ltd is the 2nd largest power producing company. Power generation started in Ashugonj power station in 1970. In the beginning the generation capability was total 128MW using two Unit s 1 & 2. Then gradually the plant improved its generating capability by installing more unites. Now the total generating capability or installed capacity of Ashugonj power station is 724 MW. In APSCL for generation of electricity engineers are using three types of generating units.

■ Steam turbine unit

- ❑ Gas turbine unit
- ❑ Diesel generator unit.

The generator of gas turbine unit and steam turbine unit are same. So we will know about the generator first.

2.3 Generator of Gas Turbine and Steam Turbine Unit:

In our house and in different industry AC current is used. So the power generating plants mostly use AC generator to produce AC current. That's why Ashugonj power plant have only AC generator to produce AC current. In Gas turbine and steam turbine units of APSCL same type of AC generator is used. These generators are different in production capability. Most of the steam turbine generators in APSCL are very high in production capability. There are 150 MW, 56.7 MW and 32MW generator used in different units in APSCL.



Figure 2.1: 150 MW AC generator of unit 3 .

2.3.1 Description of AC Generator in APSCL:

The turning of a coil in a magnetic field produces motion emf in both sides of the coil which add. If the velocity perpendicular to the magnetic field changes sinusoidally with the rotation, the generated voltage is sinusoidal or AC. And this generator used in AC current generation is known as AC generator which is used in APSCL. The main generating method of APSCL is based on this procedure.

AC generator based on this method has different parts. By visiting and instructions of APSCL instructors, structure of generators and parts used in it is clear to us.

Different parts of AC generator used in APSCL are given below:

- Stator
- Rotor
- Insulation
- Exciter
- Armature Windings
- Insulation
- Jacking Oil Pump

2.3.1.1 Stator:

Generator used in Ashugonj power station com. Ltd consists of a stationary stator and a rotor mounted within the stator. It is the most important part of a generator. In many cases, depending on the configuration of generator stator may act as the field magnet, interacting with the armature to create motion, or it may act as the armature, receiving its influence from moving field coils on the rotor. In a AC generator stator contains a specific number of coils, each with a specific number of windings. In APSCL stator contains of 12 coils. These coils are placed in the stator core. It's near to the air gap.

2.3.1.2 Rotor:

In an AC generator of APSCL rotor is the only rotating part. These rotors are coupled with the turbine, which helps it to rotate. All of the rotors of AC generator in APSCL include first and second iron cores which function as magnetic poles for the rotor and which are fixed to a shaft. In APSCL they use AG generators and GEC generators which have same type of rotor. There are two type of rotor which is used in AG generator.

- Turbine driven rotor
- Salient-pole rotors.

Turbine driven rotors are used in high speed rotation. And Salient-pole rotors are use in low speed usually equal or less than 1200 rpm. In APSCL for high speed rotation turbine-driven rotor is used because the rpm of steam turbine there is 3600rpm.

2.3.1.3 Insulation:

Insulation is very important for a generator. Because it's get too much hot, if insulation is not properly used machines around generator can be damaged. In APSCL the use high temperature resistant textile and insulation board for insulation.

2.3.1.4 Armature Windings:

In an AC generator armature is the place where voltage is induced. For cutting the rotating flux there are many turns of coils in armature. These coils are known as armature winding. APSCL uses different type of high temperature resistant coils.

2.3.1.5 Exciter:

AC generator needs direct current to energize its magnetic field. There is two type of exciter used in AC generator of Ashugonj power station com. Ltd.

- Brush exciter
- Brushless exciter



Figure 2.2: DC Exciter used in 150 MW generator of unit 3.

Exciter supply's the DC excitation current to the generators fields. This is one of the most important parts of an AC generator. Because, DC excitation is must to produce field. In CCPP of APSCL they use brush less exciter and in ST they use brush exciter.

2.3.1.6 Jacking Oil Pump:

Jacking oil pump is one kind of high pressure pump which is used to left rotor shaft. In CCPP of APSCL generator shaft is very heavy. In operating time there is no need of jacking oil pump in AC generator, but when generator is not working, for cooling and steeling down its need to rotate using turning gear.



Figure 2.3: Jacking oil pump in 36.7 MW generator of CCPP.

But turning gear rotates in a slow RPM. So oil which reduces friction in active generation mode can't circulate using the high RPM. So it can damage the bearing and shaft. It also reduces the lifetime of shaft. So to reduce this friction jacking oil pump is used. Its delivers oil at a high pressure in the lower portion of shaft and bearing. Which lift up the shaft to reduce the friction. It works until the turning gear is off.

2.3.2 Synchronization with the Power Grid:

Synchronizing the generator with the power grid is one of the major tasks for the engineers. Synchronizing is the method to maintain the same frequency, phase angle, voltage and phase sequence of the generator with the grid. Because, without synchronizing if we connect the

generator with power grid, both power grid and generator will be heavily damaged as well as the consumers. In the past, synchronization was performed manually using three-lamp method using Synchroscope. Nowadays, the process is automatically operated and controlled with the aid of synchronization relays.



Figure 2.4: Synchroscope in the control room of 150 MW unit 3.

In APSCL in most of the old units are synchronized using Synchroscope. Its manual method of synchronization relies on observing an instrument. It displays the relative frequencies of system and generator. The pointer of the synchroscope will indicate "fast" or "slow" speed of the generator with respect to the system.

As we know, the speed and frequency of a synchronous AC generator is related by the formula:

$$F = (P * N) / 120$$

F = Frequency, in Hertz

P = Number of poles of the generator rotor

N = Speed of the generator rotor

So from here we can see, the generator must rotate at a speed such that the generated power frequency is equal to the grid's frequency.

And also to synchronize perfectly, generated voltage and phase angle & sequence must be matched with the power grid.

2.4 Steam Turbine Power Plant:

Steam turbine power plant use steam to rotate the turbine which is coupled with the generator. For this, steam needs to hit the turbine in high speed and also with a high temperature. So, water is the most important thing for a steam turbine power plant. Before constructing a steam turbine power plant we need to insure the supply of water.

In APSCL there are 6 units of steam turbine power plant including the one in combined cycle power plant. Installed capacity of steam power plant in APSCL is 578 MW excluding the CCPP. But now it produces 520 MW power.

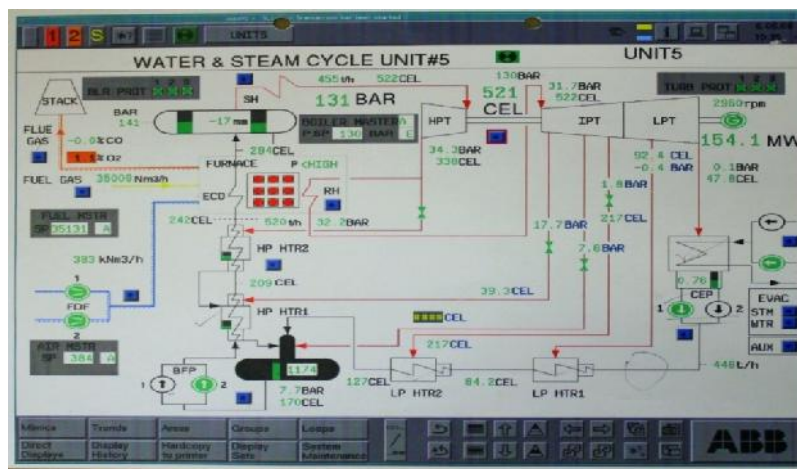

Figure 2.5: Water and steam cycle of 150 MW & 15.75 KV unit 5.

In APSCL water and steam cycle is shown in the previous figure. To produce steam for the steam turbine Ashugonj power station collect water from river Meghna. They use some huge pumps to drag the water in to their water treatment plant. We all know in river water there are different type of mineral and its PH can differ time to time. If we use this type of normal water to make steam then both the boiler and the turbine will be damaged in the long run. So first of all, water is de-mineralized and also its PH is controlled using different type of chemicals.

After this the water is forced to the boiler using some pumps. These boilers are water tube boiler. It means water flow through the tube and around these tubes there will be high temperature. As a result steam is produced and its temperature is 170-175°C and pressure 30 bars. Then steam goes

to Supper heater (SH) and its temperature increases to 520-525°C and pressure 135-138 bars. After that it goes to High pressure turbine (HPT) and then to Re-heater (RH). After this steam temperature decrease to 330-332°C and pressure 32 bars. Using RH these steams temperature becomes 520-525°C and pressure 135-138 bars. After that these steam is taken in intermediate pressure turbine (IPT) and then low pressure turbine (LPT). Then the turbine stars to rotate and electricity produces. The exhaust of LPT enters in condenser. Now both temperature and pressure becomes to 44-45°C and 0.1 bars. Next it is taken to LPH1 and LPH2 at temperature 125-130°C and pressure is very low. This steam is taken now from BFP to boiler drum through HPH1 & HPH2 and again in turbine.

Discretion of different parts of Steam turbine power plant in APSCL will be given below.

2.4.1 Steam Turbine:

A turbine is a rotary engine that extracts energy from a fluid flow and converts it into useful work. The simplest turbines have one moving part, a rotor assembly, which is a shaft or drum with blades attached. There are two type of turbine used in Ashugonj power station biased on their steam flowing process.

2.4.1.1 Impulse Turbine:

A turbine that is driven by high velocity jets of water or steam from a nozzle directed on to vanes or buckets attached to a wheel. The resulting impulse spins the turbine and removes kinetic energy from the fluid flow. Before reaching the turbine the fluid's pressure head is changed to velocity head by accelerating the fluid through a nozzle.

The energy to rotate an impulse turbine is derived from the kinetic energy of the steam flowing through the nozzles. The term impulse means that the force that turns the turbine comes from the impact of the steam on the blades. An example of impales turbine Pelton turbine. In APSCL impulse turbine is used in all steam turbine power plants also in the steam turbine part in CCPP. There are three different types of this impulse turbine in APSCL according to their use and steam pressure level.

2.4.1.2 HP or High Pressure Turbine:

It is built for highly rough situation. Because high speed steam at first enter and hit the turbine from the supper heater. Which can cause a have torque to the turbine shaft. That's why turbine blades are small compare to others. It's an impulse turbine.

2.4.1.3 Low Pressure Turbine:

Steam comes from IP turbine to LP turbine. In LP it expands and creates pressure on the turbine. But in LP chamber, pressure or steam is lower than others. So turbine blades are comparatively larger than others.



Figure 2.6: LP turbine used in 150 MW & 15.75 KV of APSCL.

2.4.1.4 Intermediate Pressure Turbine:

In this case the steam comes from RE-heater and goes to the low pressure turbine section. It's a medium pressure section. So turbine blades are medium and pressure is also medium.

2.4.1.5 Reaction Turbine:

A reaction turbine also rotates its blades due to the impending pressurized steam, but the steam does not strike the blades perpendicular, as in an impulse turbine. The steam is directed to flow along the blades, thus causing the blades to rotate because of the reaction force more than the impulse force. The reaction turbine has a nozzle design that is incorporated on its blades itself,

thus reducing space and making it more compact, as no fixed nozzles were required. So, when the steam escapes through these tubes, it expands and there is increase in steam velocity relative to the rotating disc. The only constraint here was that the design of the nozzles on the blades was a bit complicated; otherwise, the reaction turbine was a straight winner. Friction was reduced and it was easily more efficient than its impulse counterpart.

Unfortunately we can't see this, because there is no reaction turbine used in APSCL.

2.4.2 Burner:

Burner is one of the most important parts of a power plant. Bourne or furnace in a power plant mainly refers to the water tube boiler furnace for fossil fuel, used in steam generating stations of modern steam power generating units. Furnace or burner is the chamber in the boiler where natural gas or coal is burned with the presence of air for producing heated gas or flue gas. In Ashuganj Power Station Company Ltd (APSCL) natural gas is burned with the presence of air for generating heat for making steam. The main parts of burner is a boiler drum and associated tubing forming the walls of the furnace in which water is boiled into steam. In APSCL in every unit there are 9 burners. It generates 1200~1500°C inside each burner. At first the burner needs small amount of natural gas and air to start the burning process. This small amount of gas is known as ignition gas. In APSCL this gas comes from Titas gas field which is supplied into the burner. Then a steak known as igniter starts the process. After combustion in furnace the saturated steam goes to boiler drum.



Figure 2.7: Burner used in 150 MW & 15.75 KV of APSCL.

2.4.3 Boiler Used in APSCL:

The part in which steam produced is known as boiler. To produce steam heats liquid water is the input and output is high pressure steam. Temperature in the boiler is very high. There are two type of boiler used in power plants:

- ❑ Water tube boiler.
- ❑ Fire tube boiler.

In Ashugonj power station com. Ltd water tube boiler is used to produce steam.

2.4.3.1 Water Tube Boiler:

This type of boiler works on a simple principle. If there is a tube filed with water. And we heat that tube, and then water will be steam. In a water tube boiler same principal is followed. In a water tube boiler bank of water tubes are connected with steam-water drum through two sets of headers. The hot flue gases from the furnace are flow around the water tubes and transfer heat energy to the water inside the tube. This is how steam produced in water tube boiler.

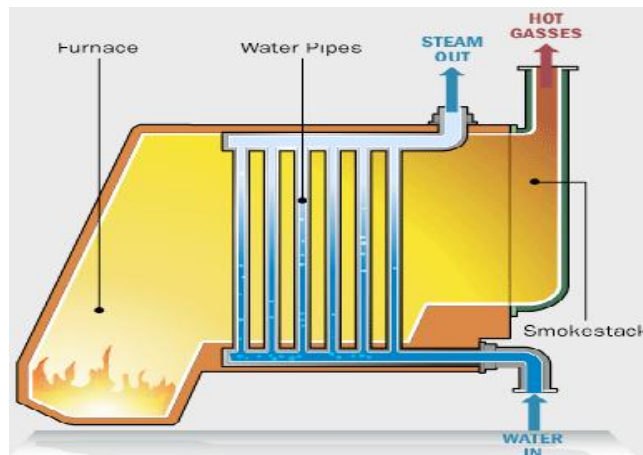

Figure 2.8: Water tube boiler used in all 150 MW & 15.75 KV generating unit.

In APSCL they prefer water tube boiler because of some reasons given below:

- ❑ Water tube boiler is Suitable for high steam pressure (above 500 psig) and temperature (to 1000 F) and large capacities exceeding millions of lb/h of steam.

- ❏ Extended surfaces can be used in waste heat applications to make the boilers compact if the gas stream is clean.
- ❏ Super heaters if used can be located at the optimum gas temperature region shielded by any number of screen tubes. In fire tube boiler the choice is at the gas inlet or exit.
- ❏ Due to low water volume, the startup time is lesser and response to load changes is faster compared to fire tube boilers.
- ❏ If the gas pressure is high, say above 5 psig, the shell/casing design gets complicated and expensive though it can be done.
- ❏ Due to higher heat transfer coefficients surface area required is lesser and hence gas pressure drop is also lower.
- ❏ For multiple pressure designs as in APSCL exhaust applications, water tube is the only choice.

2.4.4 Flue Gas:

Flue gas is generated in the burner. To generate flue gas different plant use different type of fuel. In APSCL natural gas mixed with air helps to burn and creates flue gas in the burner. From burner it circulates in the plant and transmits heat to water for steam generation. In steam power plant of Ashuganj Power Station Company Ltd the flue gas is produced by burning natural gas which comes from the Titas Gas Transmission and Distribution Company Ltd.

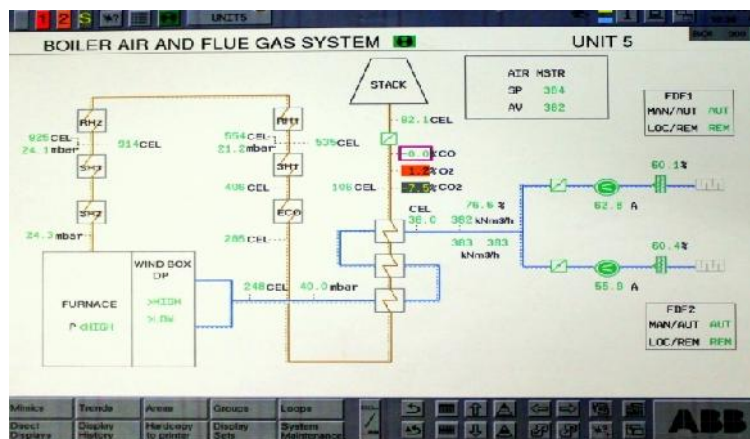

Figure 2.9: Boiler and flue gas system of 150 MW & 15.75 KV unit 5.

2.4.5 Forced Draft Fan or FD Fan:

It's a fan which drags air inside. This is connected to burner, it collects air from nature and pass to burner. Burner uses this air for burning gas. It's a huge fan, usually placed outside of the plant in an open place.



Figure 2.10: FD fan for 150 MW & 15.75 KV unit 4.

2.4.6 Super Heater or SH:

Super heater is a part of boiler. It's used to increase the temperature of the steam. There will be no water particles in the super-heated steam. So the super heater converts the wet saturated steam into dry high temperature steam. Steam circulate in this chamber and gets high temperature. The circulation of steam is shown below.

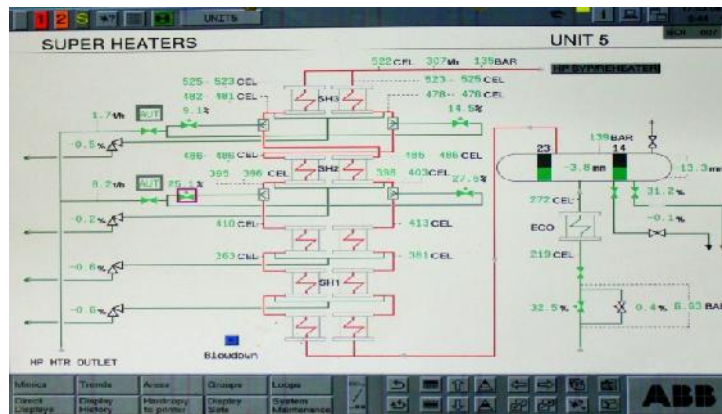

Figure 2.11: Super heater cycle in 150 MW & 15.75 KV unit 5.

So we can say that super heater is a device found in steam boilers that is used to convert wet, saturated steam into dry steam. Super heaters are a very beneficial part of the steam cycle, because dry steam contains more thermal energy and increases the overall efficiency of the cycle. Radiant super heaters are located directly within the combustion chamber of the boiler itself. This arrangement allows for the burner from the boiler to heat both the boiler tubing and the super heater tubes, making radiant super heaters highly effective devices. Some specification of APSCL super heater is given below.

Table 2.1 : Configuration of super heater used in APSCL.

| | |
|--------------------|--------------------|
| Max pressure | 110 bar or 171 bar |
| Normal pressure | 93 bar or 138 bar |
| Normal temperature | 525°C or 523°C |

2.4.7 Re-heater or RH:

Re-heater is the part of a power plant which is used to re-heat the exhaust gas from the high pressure turbine. After high pressure turbine steam gets colder but still can be used. So to use that steam, we need to heat it otherwise it will not work to rotate the turbine. That's why steam comes from high pressure turbine goes to re-heater. In each unit of APSCL have 2 re-heaters. This re heaters is placed inside the boiler.

From re-heater the re heated steam goes to intermediate pressure turbine and by expanding it rotates the IP turbine. Process of re heating in a re-heater is containing tubes of steam heated by hot flue gases outside the tubes. Exhaust steam from the high pressure turbine is passed through these heated tubes to collect more energy before driving the intermediate and then low pressure turbines. Steam goes in to re-heater and comes out about 522°C temperature and 29.4 bar pressure from it.

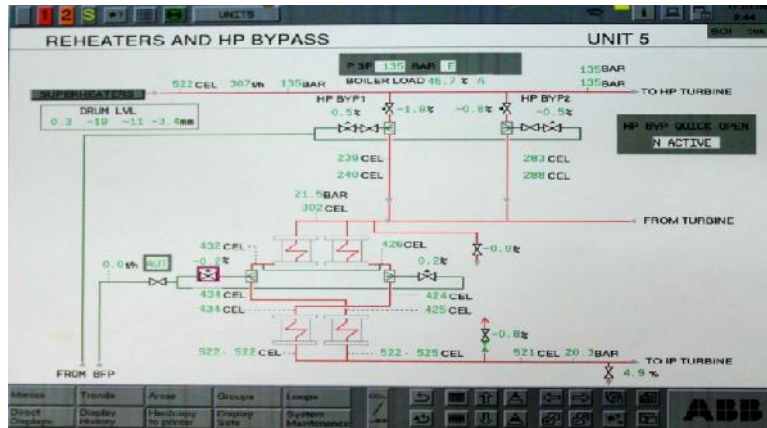

Figure 2.12: Re-heater system in 150 MW & 15.75 KV unit 5.

2.4.8 Feed Water Heater:

A feed water heater is a heater which increases the temperature of water and transfers it to boiler to produce steam. Preheating the feed water reduces the irreversibility's involved in steam generation and therefore improves the thermodynamic efficiency of the system. The heating process of feed water is done by using steam which comes from HP, LP and IP turbine through steam extraction line. Feed water heater temperature in APSCL is given bellow.

Table 2.2: Feed water temperature in APSCL

| | Unit 12 and 345 |
|-----------------------------------|-----------------|
| Feed water temperature (overall) | 229°C and 246°C |
| LP feed water heater temperature | 127°C |
| HP feed water heater temperature | 229°C and 246°C |

In Ashuganj Power Station Company Ltd (APSCL) there are two types of feed water heater used. These are:

- ❑ Low pressure feed heater or LP feed heater
- ❑ High pressure feed heater or HP feed heater

2.4.8.1 LP Feed Water Heater:

Low pressure feed water heater use the steam comes from intermediate and low pressure turbine to heat the water.

In Ashuganj Power Station Company Ltd water temperature rises up to 127°C when its passes through low pressure feed water heater. Steam from IP and LP turbine which are 222°C and 91.2°C in temperature are used to heat the water in to 127°C inside the LP feed water heater.



Figure 2.13: Low pressure heater in 150 MW & 15.75 KV unit 4 at APSCL.

2.4.8.2 HP Feed Water Heater:

High pressure feed water heater use the steam comes from high and intermediate pressure turbine to heat the water. Feed water is drag to HP feed water heater using feed pump.

Feed water is pumped from the feed water tank by boiler feed pump into the HP heater. Steam from HP and IP turbines is extracted by extraction line and flowed over the tubes which carry feed water. The steam releases heat and feed water receives heat. Steam from HP and IP turbines are forced to flow over the tubes which carry feed water. So steam transfers the heat to water which increase the temperature of the feed water. In every unit in APSCL there are two HP feed water heater.

2.4.9 Chimney:

A chimney is equipment which helps to venting hot flue gases and smokes from boiler to the outside in atmosphere. Flu gas in the power plant produced in burner. And it helps to produce steam and in water heating process. After all this it escapes through chimney to the atmosphere.



Figure 2.14: Chimney in 64 MW & 11 KV units 1.

2.4.10 Economizer:

Economizer is a heat exchanger device in boiler part that captures the lost or waste heat from the boiler's hot stack gas. Economizers are designed to save energy. It re use the heat to reduce heat loses. It helps to gain of about 10% in the plant efficiency by doing this. And also reduce the loss of heat through flue gas. So it also helps to reduce the cost of fuel. That's why each and every unit in APSCL uses economizer.

2.4.11 Water Treatment Plant:

The process of electricity generation from fossil fuels such as coal, oil and natural gas is Water intensive. So in APSCL process of electricity generation from natural gas requires water supplies for a number of essential power plant processes. The principal impurities present in these waters are total dissolved solids, suspended solids or particulate matter, colloidal species and dissolved organic matter. It is these impurities and their respective levels in the water supply that determine the suitability of the water for use in the various processes of a power plant, or the necessary

treatment requirements to make it acceptable for use. To make this water acceptable for generation it's first treated in water treatment plant. It's a vital element for a power station. In APSCL water treatment plant PH of water is also controlled using different type of chemicals like $Al_2(SO_4)_3$ and polyelectrolyte.



Figure 2.15: Water treatment plant in APSCL.

2.4.12 Deaerator:

Deaerator is a device that is widely used for the removal of air and other dissolved gas from the feed water to deliver it in steam-generating boilers. The removal of dissolved gases from boiler feed water is an essential process in a steam system. The residual oxygen and non-condensable gases contained in the condensate are eliminated in a deaerator incorporated in the feed water heating circuit. There are many different horizontal and vertical deaerators available from a number of manufacturers. Reasons why APSCL is using Deaerator in power generation:

- ❏ It increase its efficiency and optimum thermodynamic utilization
- ❏ In this case Very low heat losses.
- ❏ High operating reliability due to simple, robust concept
- ❏ Reliable heating-up and maintaining its temperature as required.



Figure 2.16: Deaerator in 150 MW & 15.75 KV unit 3 at APSCL.

2.5 Combined Cycle Power Plant Section in APSCL:

In a combined cycle power plant (CCPP), or combined cycle gas turbine (CCGT) plant, a gas turbine generator generates electricity and heat in the exhaust is used to make steam, which in turn drives a steam turbine to generate additional electricity. So we can say Combined Cycle power plants are those which have both gas and steam turbines supplying power to the network. In a combined cycle power plant, a gas turbine generator generates electricity and the waste heat is used to make steam to generate additional electricity through a steam turbine, which enhances the efficiency of electricity generation. In APSCL there are two gas turbines and a single steam turbine generator is used as CCPP or combined cycle power plant. The gas turbine units are known as GT1 and GT2, and the steam turbine unit is known as ST.

Table 2.3 : Description of CCPP (146MW) in APSCL

| | Gas Turbine 1 | Gas Turbine 2 | Steam Turbine |
|------------------|---------------|---------------|---------------|
| Install capacity | 56MW | 56MW | 30MW |
| Now generation | 40MW | 40MW | 18MW |
| Establish in | 1982 | 1986 | 1984 |
| Company name | GEC,UK | GEC,UK | GEC,UK |
| Rated speed | 3000 rpm | 3000 rpm | 3000 rpm |

So combined cycle power plant can be deviated into two parts:

- Gas turbine section.
- Steam turbine section.

2.5.1 GT or Gas Turbine Section in CCPP of APSCL:

A gas turbine uses a compressor to suck in and compress gas (usually air), a combustor to add fuel to heat the compressed air, and a turbine to extract power from the hot air flow. Gas Turbines are internal combustion engines that implement a continuous combustion process. An intermittent combustion process characterizes IC engines used in automotive or diesel applications. The hot gas formed in the combustion chamber expands through the turbine, producing mechanical power.

2.5.1.1 Compressor:

In gas turbine section compressor is one of the most important part. Compressor is a device which compresses air. And it supplies this compressed air in combustion chamber to help in combustion. The compressor used in the plant is generally rotator type. The air at atmospheric pressure is drawn by the compressor via the filter which removes the dust from air. It's also known as Axial-flow compressors also.

2.5.1.2 Diesel Engine:

Diesel engine is essential in gas turbine section in CCPP. The gas turbine has no self-exciting mechanism. The turbine only can be rotated if fuel and air is burned inside the combustion chamber. But air can go into the combustion chamber if the turbine blade moves. So to push air into combustion chamber initially, an external help is needed to rotate the turbine. And this job is done by a diesel engine coupled with a turbine. When the turbine starts to move by the diesel engine at a rated speed which makes the compressor to suck air by itself then the diesel engine is turned off automatically. This rated speed in no load is 3000rpm.



Figure 2.17: Diesel engine in 56 MW & 13.8 KV GT of CCPP.

2.5.1.3 Turbine in GT Section:

The turbine converts gaseous energy into mechanical energy by expanding the hot, high pressure gases to a lower temperature and pressure. Each stage of the turbine consists of a row of stationary vanes followed by a row of Rotating blades. This is the reverse of the order in the compressor. As the mass of the high velocity gas flows across the turbine blades, the gaseous energy is converted to mechanical energy. Velocity, temperature, and pressure of the gas are sacrificed in order to rotate the turbine to generate shaft power.

2.5.1.4 Combustor:

When the air flows through the compressor it enters the combustion section, also called the combustor. Task of combustion section is to controlling the burning of large amounts of fuel and air. It release the heat in a manner that the air is expanded and accelerated to give a smooth and stable stream of uniformly-heated gas at all starting and operating conditions. This task must be accomplished with minimum pressure loss and maximum heat release. In addition, the combustion liners must position and control the fire to prevent flame contact with any metal parts. This section of power plant is not visible from outside. It's inside of the main frame.

2.5.1.5 Exhaust:

When the gas passed through the turbine, it is discharged through the exhaust. Though most of the gaseous energy is converted to mechanical energy by the turbine, significant amount of power remains in the exhaust gas. This exhaust gas is transferred to nature using exhaust if the steam turbine is not in use. If steam turbine section is in use, then a valve inside the exhaust converts the direction of exhaust gas to steam turbine.

2.5.2 ST or Steam Turbine Section of CCPP in APSCL:

Exhaust gas from gas turbine section is used here to produce steam. So efficiency of the plant increases very much. Exhaust gas coming from GT section contain high temperature. Which is use to evaporate water and create steam. And this is the main difference between the steam turbine sections of combined cycle power plant and the steam turbine section of steam power plant. Because in case of normal steam power plant there is a furnace which produces the heat or flue gas but in the combined cycle there is no furnace. The role of flue gas in this case is done by exhaust gas from the gas turbine section.

2.5.2.1 Turbine in Steam Turbine Section:

There is a small difference between the normal and CCPP steam turbine. Steam turbines for combined-cycle power plants generally are of two styles. Steam turbines with different exhaust annulus areas are available to permit optimization to meet specific condenser cooling conditions. In most combined cycle power plant as also in APSCL steam turbine have two sections:

- HP or High pressure turbine
- LP or Low pressure turbine

2.5.2.2 Super Heater in ST:

To produce enough rotation in turbine, it needs high heated steam in high velocity. That's why supper heater is used to increase the temperature of the steam. It's in the bottom of the plant. Exhaust gas is flowed over the bundle of tubes which carry the steam. Temperature of the

exhaust gas from gas turbine is about 500°C; this gas is used in super heater as heating element. From the super heater the super-heated steam goes to the high pressure turbine. When the steam get heated using super heater its temperature rises to 400°C which goes to high pressure turbine directly.

2.5.2.3 Condenser:

Water in steam power plant is very important. But it cant be used without treatment. And after treatment it should be used several times because of time and environment effect. So steam need to converts to water again and again. For this reason condenser is used in steam turbine power plant in CCPP. So, Condenser is a device which condenses the steam at the exhaust of turbine. It serves two important functions. Firstly, it creates a very low pressure at the exhaust of turbine, thus permitting expansion of the steam in the prime mover to a very low pressure. The condenser includes a plurality of heat pipes configured to extract latent heat from steam passing from the steam turbine section to form condensed water.



Figure 2.18: Condenser in steam turbine of 34 MW & 13.8 KV in CCPP.

2.6 Gas Engine Power Plant in APSCL:

Newest addition to the Ashuganj power station co ltd is 53 MW gas engine power plants. In this unit gas engine rotates the generator shaft to produce power. Gas engine means an engine that running on a gas. Gas engine use natural gas for this process. In APSCL gas from TITAS gas field is directly supplied to this unit. Just like a Diesel engine, a gas engine use gas for internal

combustion. And the shaft is coupled with generator. In this case generators are same as steam turbine generator. Steam turbine generators are huge; on the other hand gas engine generators are not as big as steam turbine. Description of APSCL gas turbine power plant is given below:

Table 2.4 : Description of gas engine power plant in APSCL

| | |
|---------------------------------|------------------------|
| EPC contract price | USD 40925000+202914500 |
| Financer | APSCL |
| EPC contractor | TSK, Spain |
| Contract agreement signing date | July 25, 2010 |
| Implementation period | 233 days |
| Commercial operation date | April 30, 2011 |
| Generation capacity | 53 MW |
| Engine model | GE, J 620 GS-F101 |
| No of engine | 16 |
| Capacity of each engine | 3332 KW |
| Country of origin | Austria |
| fuel | Natural gas |
| Project area | 9080 Sq. meter |

Gas engines are usually small in size. That's why APSCL is using 16 different engines to produce power. Each of the gas engine power plants is producing 3332 KW. Gas engines generators that run on natural gas are typically between 35-45% electrically efficient, the best products can achieve an electrical efficiency at more than 48%. The engine used in APSCL is GE J620; this engine is a 24 cylinder gas engine with a high efficiency running on methane.



Figure 2.19: 3332 KW, GE J 620 GS-F101 Gas engine power generators used in APSCL.

2.7 Control Room of Generator:

Control system of generator in APSCL is mainly two types: Analog and digital. The units which are very old usually have analog control system, and the more recent units are using digital control system. In normal condition when the plant is running without any fault, engineers monitor and control the system from the control room. If any fault occurs then they can monitor that from the room. But solving the fault is not possible from the control room in most cases.



Figure 2.20: Analog monitoring parts of 64 MW & 11 KV unit 1.

Unit 1&2 are very old, they use analog control system to control the generation. Same type of analog control system is use to control CCPP.



Figure 2.21: Analog control system in a control room of 64 MW & 11 KV unit 1.

On the other hand new generation units are using digital control room. In unit 3, 4 and 5 they are using two different type of digital control system. In unit 3 and 4 APSCIL is using PLC (Programmable Logic Controllers). It's a digital controller which is control by different switches.



Figure 2.22: PLC controlled control room in 150 MW & 15.75 KV unit 4.

Another type of digital control system is used in APSCIL. It's the most advanced method of controlling generation. Its software biased control system. All the things are controlled using a computer monitor.



Figure 2.23: Software based control system in 64 MW & 11 KV unit 5.

2.8 Future Projects of APSCL to Increase Generation:

a) Ashugonj 225 MW combine cycle power plant:

APSCL is going to establish a 225 MW combine cycle power plant very soon. The agreement is already signed. The features of the plant are given below:

Table 2.5: Description of 225 MW plant.

| | |
|-------------------------------|----------------------------|
| Capacity | 225 MW |
| Contact price | USD 61970240+ EUR 60362742 |
| Contact agreement signed date | October 5, 2011 |
| Expecting date of completion | April, 20114 |
| Project duration | 25 month |
| Fuel | Natural gas |

b) Ashugonj 450MW combine cycle power plant(south):

Another 450 MW CCPP is going to be installed very soon. Description of the project is given below:

Table 2.6: Description of proposed 450 MW CCPP.

| | |
|--------------------------|-----------------|
| capacity | 450 MW |
| Cost | BDT 3333 Crore |
| Project completion time | 27 months |
| Contact agreement signee | June, 2012 |
| completion | September, 2014 |
| fuel | Natural gas |

c) Ashugonj 225 MW combine cycle power plant(North):

In the northern part of APSCL, there will be another combined cycle power plant. Install capacity of that plant is 450 MW. A brief particular of the project is furnished below:

Table 2.7: Description of 450MW CCPP (north).

| | |
|------------|----------------|
| capacity | 450 MW |
| cost | BDT 3400 crore |
| Completion | October, 2015 |
| fuel | Natural gas |

2.9 Conclusion:

Generation is the main goal of a power plant. In this chapter we described how Ashugongj power plant is producing power. APSCL is trying to generate there maximum possible output. APSCL has a large number of skilled engineers and workers who try their best to improve its capability. Modification of the turbine and generator in unit 3 was done by its own engineers when our intern group was in APSCL.

From the discussion of this chapter we now have a clear idea about the generation of power in Ashugonj power station. Description about the equipment's in different power plant in APSCL is given. Briefly discussed on APSCL's newest addition gas engine power plan is also given. This section also covered the description of ST, GT and CCPP generators in details. Different parts of generator and there functions are discussed clearly and different pictures which are very hard to find is also attached in this section. APSCL's most efficient generation unit combined cycle power plant (CCPP) is discussed clearly with its different turbine sections. Different type of control system for generation is discussed. Future plans of APSCL are discussed according to their annual reports. At the end of this chapter we can say, this chapter covers the whole generation section of Ashugonj power station co. ltd clearly and descriptively.

Chapter 3

3 Controlling Valve:

3.1 Introduction:

A valve is a device which can be used to control the flow of liquids, gases, and slurries. Control valves are valves used to control conditions such as flow, pressure, temperature, and liquid level by fully or partially opening or closing in response to signals received from controllers that compare a "set point" to a "process variable" whose value is provided by sensors that monitor changes in such conditions. The opening or closing of control valves is usually done automatically by electrical, hydraulic or pneumatic actuators.

In APSCL there are a number of different designs for valves depending on how they are being use. The basic valve types can be divided into two general groups: stop valves and check valves. Many special valves, which cannot really be classified as either stop valves or check valves, are found in the engineering spaces. Many of these valves serve to control the pressure of fluids and are known as pressure-control valves. Other valves are identified by names that indicate their general function.

These sections are described by Engr.Bikash Ranjan Roy .Our working schedule was 27th and 28th December from 8am to 4pm.

3.2 Gas Pressure Reducing Valve:

Gas is the major component of ashuganj power station. Gas turbines and burners of all units are totally dependent on the gas. The pressure of the gas should control. In the gas station there has a valve called solenoid valve. At first, the pressure of the gas may be higher than 30 bar. The solenoid valve controls the gas pressure of 4.5 bars. If the gas pressure increases then this valve has a meter, which shut off the valve.



Figure 3.1: Gas pressure reducing valve.

This valve is used for filtering the gas. The gas which is used for the combustion in the combustion chamber should be moisture free. This valve protects gas from moisture and passes the pure gas.



Figure 3.2: Gas filter inlet shut off valve.

3.3 FD Fan Air Flow Control Valve:

In the combustion chamber of the burner one of the most important elements is air. This air is taken using force draft fan. Flows of the air are controlled by the control valve. It is an analog control valve. This valve can be operate automatically by a motor also, where it has a manual operation system



Figure 3.3: FD fan air flow control valve.

3.4 Water flow Controller:

It behaves like a switch. That means if we turn on a switch then it allows to flow water here if the teeth is at 100 position then it allows to flow the water fully and when it is in 0 position then it does not allows any further flow of water.



Figure 3.4: Water flow control valve.

3.5 Super Heater Safety Valve:

Supper heater is used for make steam from the water. The temperature of the supper heater may be 300 CEL to 500 CEL. But this temperature can be increased abnormally, if the pressure of

steam becomes unbalance. The abnormal heat may cause a big damage of the supper heater. The maximum steam pressure of supper heater is 93 BAR. So, when the pressure of steam passes the limit then extra heats are exhaust using supper heater safety valve.



Figure 3.5: Super heater safety valve.

3.6 Conclusion:

A control valve regulates the flow or pressure of a fluid. Control valves are normally fitted with actuators and positioners. Control valves can also work with hydraulic actuators. These types of valves are also known as Automatic Control Valves. The hydraulic actuators will respond to changes of pressure or flow and will open/close the valve.

Chapter 4

4 Protection Systems of Plant:

4.1 Introduction:

Protection system of a power station is a very important branch of our power system engineering. The primary purpose of power system protection is to ensure safe operation of power systems, thus to care for the safety of people, personnel and equipment.

At Ashuganj Power Station Company Ltd there have large number of protection system which provides safe and reliable working place for its engineers and workers .In our intern period ,we got a basic idea about some important protection system such as generator protection, transformer protection, turbine protection, bus-bar protection, transmission line protection, boiler protection etc.

Generator Protections are described by Engr.Mohammad Kamruzzaman at 8th January. In I&C section Engr.Bikash Ranjan Roy helped us to learn about the turbine and boiler protections. Protections of transformer, bus-bar and transmission line are described by Engr.Noor Mohammad at sub-station section.

4.2 Generator Protection:

Generators must be protected from electrical faults, mechanical problem and adverse system conditions. Some faults require immediate attention (shutdown) while others just require alarming or transfer to redundant controllers. In our intern time we have learned different type of generators protection and cooling system of generators which are using at APSCL. Important protection systems are given below-

- Over Current Protection
- Over Voltage Protection

- ❑ Reverse Power Protection
- ❑ Under Frequency Protection
- ❑ Negative phase sequence Protection
- ❑ Stator Earth Fault
- ❑ Rotor Earth Fault Protection and
- ❑ Winding differential protection

4.2.1 Over Current Protection:

Normally generators at APSCL are designed to operate always at rated MVA, frequency and power factor over a range of 95 to 105% rated voltage. Operating the generator at rated MVA with 95% voltage, 105% stator current is allowable. Operating of the generator further than rated KVA may result in damaging stator. A result of over current in winding is stator core overheating and leads to failure of insulation. If alarm with relay annunciates at annunciation panel, then the controller reduce the stator current to the below the rated by reducing the MVAR power on the generator. If a generator becomes shut down for over current then relays are also act for the, unit Breaker, steam Supply (Shut off) off, field Breaker off and, unit Auxiliary Breaker off

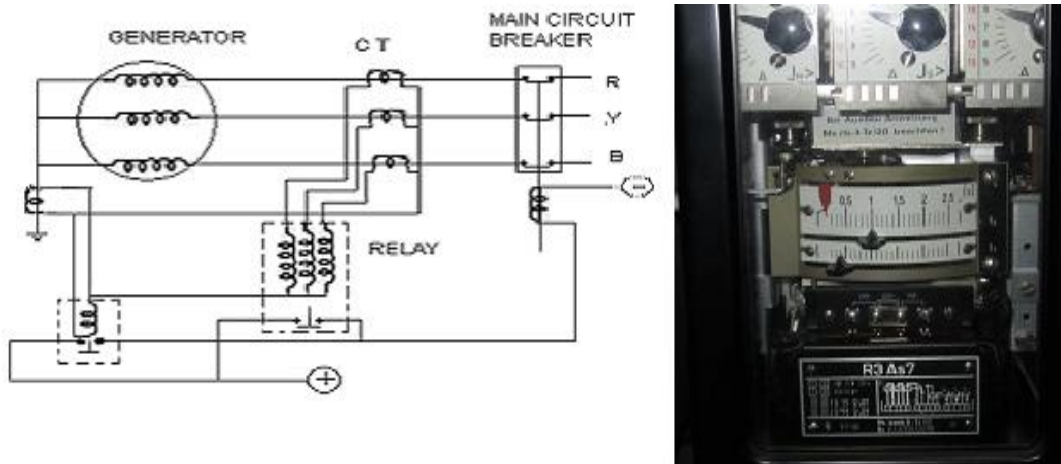

Figure 4.1: Over current protection and alarming relay.

4.2.2 Over Voltage Protection:

If an over voltage occurs in the generator and if it is persist, the circuit breaker of the generator and the exciter field breaker should be tripe because it is not safe for a generator to continue to work under this condition. In a generator the over voltage can happened for, line fault, thundering, suddenly load rejection. Etc.

The over voltage protection contain two types of relay – one is the instantaneous relays which is set to pick up at 130 to 150% of the rated voltage and another is Time delay relay which is set to pick up at 110% of rated voltage.

4.2.3 Reverse Power Protection:

It is backup protection to the low forward protection. Reverse power or Motoring of a generator occurs when the energy supply to the prime mover is cut off while the generator is still online. When this occurs, the generator will act as a synchronous motor and drive the prime mover. The generator will not be harmed by synchronous motoring, where a steam turbine can be harmed through overheating during synchronous motoring if continued long enough. The motoring of the turbine output can be detected by reverse power protection. Avoid false tripping due to power swings in a time delay, is included before tripping signal is generated. The primary concern is the protection of the turbine that may be damaged during a motoring condition.

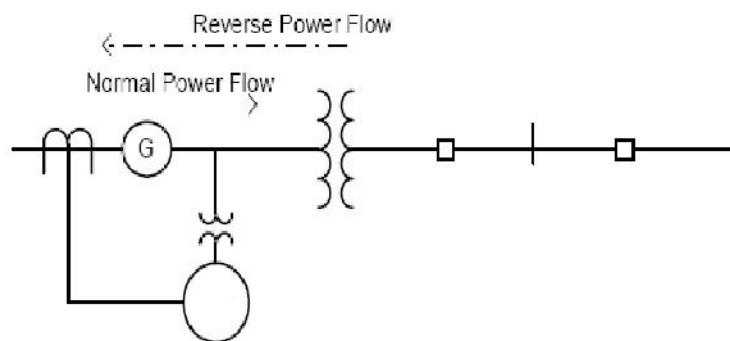

Figure 4.2: Reverse power protection.

4.2.4 Under Frequency Protection:

A generator which is connected to the system, if it operates with a under frequency then that will be the result of sever system disturbance. The generator can accept reasonable under frequency operation provided voltage, which is within acceptable limits. The abnormal under frequency on the generator may be due to unacceptable speed control adjustment. Under frequency will be occurring when the generator will operate with over load. The power system survives only if we drop the load, the generator output becomes equal or greater than the connected load.

Relays acted: Flag operation at Protection panel. Indication at Annunciation Panel .Increase governor speed until machine reaches full speed. Even after two to three attempts, the machine are running at lower speed, probably the governor of turbine is faulty. Inform to maintenance staff for rectification of the same.



Figure 4.3: Under frequency relay.

4.2.5 Negative Phase Sequence Protection:

The most common causes for the negative phase sequence are system asymmetries, unbalanced loads, unbalanced system faults, and open phases. .When a negative phase sequence occur then induce a double-frequency current in the surface of the rotor, the retaining rings, the slot wedges, and to a smaller degree, in the field winding.. For that reason the rotor will be overheated and generator can be damaged. For this imbalance current the shaft of the rotor can be vibrate .At APSCL current balance relaying equipment is used for protection against this kind of fault.



Figure 4.4: Negative phase sequence relay.

4.2.6 Stator Earth Fault:

Generally the stator of a generator is very close of the ground. When a fault is occur in a stator winding then it can easily connected with the ground. If a faulty phase winding connected to ground, the normal low neutral voltage will rise as high as line-to-neutral voltage which will be depending on the fault location. This fault may cause the serious damage .This fault can be detected by measuring secondary voltage of neutral grounding transformer. Here we have two zones for detect the fault. First zone cover 0% to 95% of the stator winding which is far from the neutral. And second zone cover 96% to 100% of the stator winding. A fundamental frequency neutral over voltage relay detect the fault of the first zone. Another third harmonic neutral under voltage relay detect the fault of the second zone.

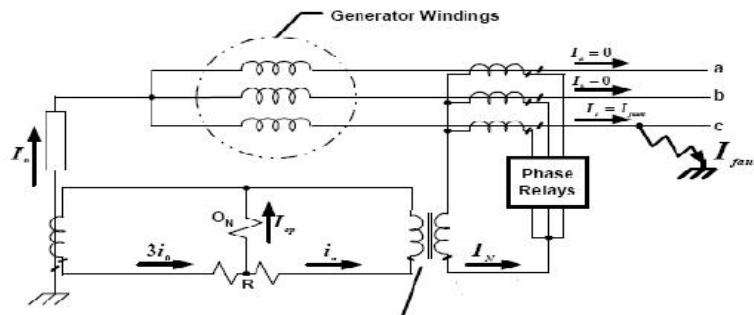

Figure 4.5: Stator earth fault protection.

4.2.7 Rotor Earth Fault Protection:

Rotor earth fault protection is one of the major protections of generator. Rotor field winding of the generator is electrically isolated from the ground. Two or more ground faults in the winding will cause magnetic and thermal imbalance plus restricted heating and damage to the rotor metallic parts. Rotor earth fault may be caused due to insulation failure of winding. The separate relay to the ground neutral provides the sensitive protection. But ground relay can also detect the fault beyond the generator, the time co-ordination is necessary to overcome this difficulty.

4.2.8 Winding Differential Protection:

This protection system is similar for the generator and transformer winding. In a plant the generating current and the transmitting current should be equal, if this current become difference then a large fault may occur and generator winding will be effected .Generally percentage differential is used for protection about 80% of the stator winding.



Figure 4.6: Generator Differential Relay.

Table 4.1: Type & model number of relays which are used at APSCL for generators protection.

| Description of Relays for Generator | Type Number | Model Number |
|-------------------------------------|-------------|--------------|
| Over Current Time Relay | R3AS7 | K01e01 |
| Over Voltage Relay | RV15 | K30e01 |
| Reverse Power Relay | TRM21 | K50e01 |
| Under Frequency Relay | RG66a | K66e01 |
| Stator Earth Fault Relay | RG5a | K25e01 |
| Rotor Earth Fault Relay | RG60a | K60e01 |
| Negative Phase Sequence Relay | RG83 | K82e01 |
| Differential Relay | RG23 | K26e02 |

4.3 Cooling System of Generator:

Generator cooling is very important for getting more life time and efficiency for a generator .At APSCL generators are cooled by two processes-

- Air Cooling
- Hydrogen Cooling.

4.3.1 Air Cooling:

A generator becomes heated for its winding temperature. This heat should remove by absorbing using any external element. Air is an element which can easily absorb this heat. In this process there have a chamber for circulating air through the generator to absorb heat. After this, hot air exhaust to outside of the generator by external exhaust chamber. For the circulation of air there have an Air circulation motor.

4.3.2 Hydrogen Cooling:

Hydrogen cooling is used for large generators rather than air. Hydrogen has inherently better heat transfer characteristic. Hydrogen can convey the heat 1.6 times more than the air. Here the cooling process is almost same as like air cooling, but it needs an external supply system which takes a large area. This system is very costly than the air cooling. APSCCL has an additional supply system for the hydrogen cooling.



Figure 4.7: Hydrogen supply station.

4.4 Turbine Protection:

Turbine is a very important part of a power plant. In APSCCL there have two types of turbine. One is gas turbine and other is steam turbine. In the steam turbine the high pressure, low pressure and medium pressure turbine are connected by a single shaft. For getting the more life time those turbine are protected by the turbine protection system (TPS). Unit 5 of APSCCL is steam turbine which is protected by some valve and switch. The important protections of the steam turbine are-

- ❑ Shaft and Bearing Vibration protection
- ❑ Lube oil pressure protection
- ❑ Shaft temperature protection and
- ❑ Over Speed Protection

4.4.1 Shaft and Bearing Vibration Protection:

Generally a turbine is rotated with more than 3000 rpm speed. With this large speed sometime shaft and bearing may be vibrating. For this vibration the blade of the turbine may lose their position and can make a big damage. If shaft or bearing start vibration then turbine become shut off by shaft vibration sensor.

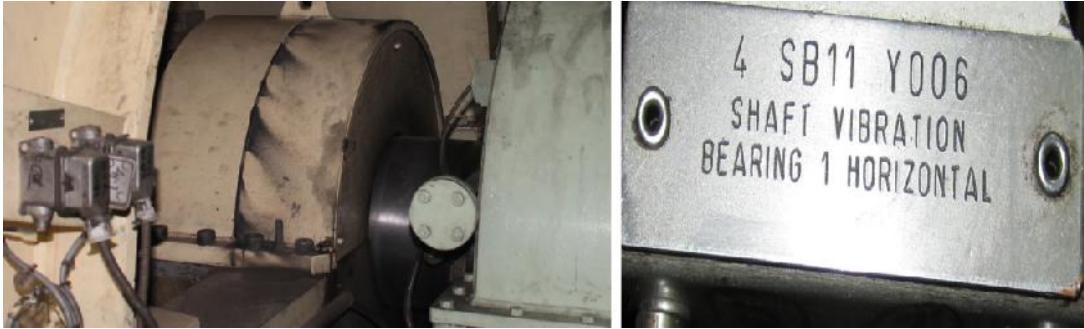

Figure 4.8: Shaft vibration sensor for unit 5 steam turbine connects with shaft.

4.4.2 Lube Oil Pressure Protection:

The vibration of the shaft can be controlled by giving lube oil on the shaft. But the pressure and temperature of this lube oil should be controlled. If pressure increases more than 60% of the set value then turbine becomes shut off by the pressure switch.



Figure 4.9: Lube oil pressure control switch.

4.4.3 Shaft Temperature Protection:

When temperatures of lube oil become increases then shaft temperature also increases. High temperature makes damage of shaft. So temperature of shaft should be limited .Shaft temperature are measure by thermocouple.



Figure 4.10: Thermocouple for measure shaft temperature.

4.4.4 Over Speed Protection:

At APSCL the synchronizing speed of the generator is 3000 rpm. So the turbine rotation speed should be 3000 rpm. If rotation speed of turbine crosses over this limit then the turbine become shut off by the breaker.

4.5 Boiler Protection:

Boiler is one of the most valuable parts for a power production system. A boiler is a closed vessel in which water or other fluid is heated. So it can be hampering by any kind of internal or external fault. Boilers of APSCL are protected by mechanical control and protective valve. Important protections of boiler are-

- ❑ Drum level high & low protection
- ❑ Furnace temperature Protection:
- ❑ Steam pressure protection
- ❑ Flue gas damper protection

4.5.1 Drum Level High & Low Protection:

The water level in the steam drum has to be maintained within the desired limits. The reduction of drum level below the low level mark will cause tube failures and level above the high level mark will cause water carry over to the turbine. A trip alarm will go to the control room if level of the water breaks the allowable limit. A level indicator is attached with the boiler drum for sense the water level

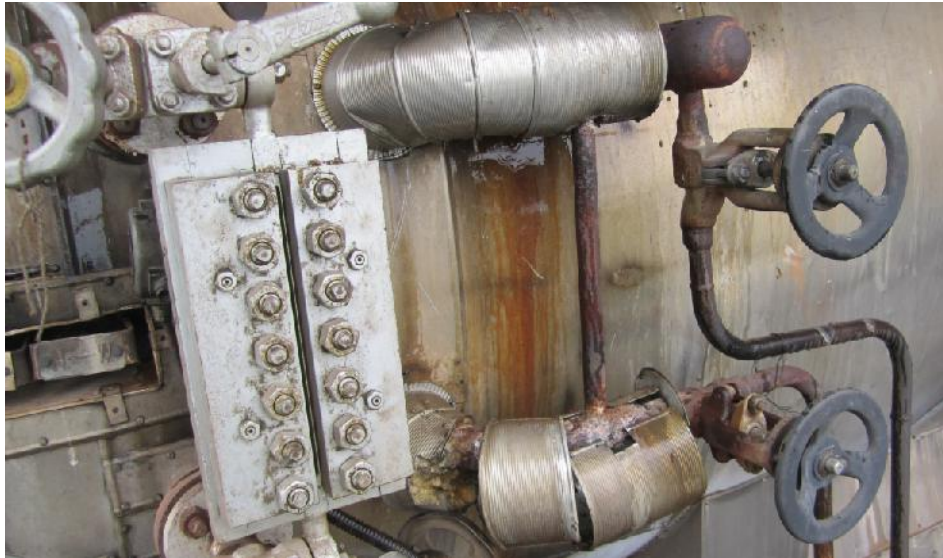

Figure 4.11: Boiler drum level indicator.

4.5.2 Furnace Temperature Protection:

High heat of the furnace chamber can make tube failure. It is require controlling the rate of heat input into the boiler and maintaining the flue gas temperature leaving the furnace at around 540 deg Cel.

4.5.3 Steam Pressure Protection:

The pressure of the steam into the boiler drum has a limit. Generally the normal pressure of the steam into the boiler dram is 100 bars and maximum value may be 130 bar. When steam pressure do exceed of the maximum limit then the dram safety valve reduces the extra pressure. If valve

do not operate then the steam pressure protection junction box will operate and trip the breaker of the drum.



Figure 4.12: Steam pressure safety valve of boiler.

4.5.4 Flue gas Damper Protection:

After the combustion into the combustion chamber there have make a burn gas that is known as flue gas. This flue gas is used for heat the boiler drum .But extra heat can be harmful for the drum .Damper can reserve and exhaust this extra heat. There have a motor with the flue gas damper protection system. This motor runs the damper which known as damper motor.



Figure 4.13: Flue gas damper of boiler.

4.6 Transformer Protection:

The fault occurring of a transformer is less with respect to a generator. Transformer needs protection against over heat. Over heat can happen for the different kind of short circuit and overload of a transformer. Sometime the body of the transformer may be affected for the external fault. Due to this reason transformer of APSCL are protected by some important protection system. The main protections of APSCL's transformer are-

- Short-circuit and Over Current Protection
- Oil Temperature Indicator(OTI)
- Pressures relay Device (PRD)

4.6.1 Short-circuit and Over Current Protection:

In a transformer a short circuit can be happen for the phase to earth fault. When fault occur then current passing through the winding increases and winding temperature becomes very high. It can make a large damage of transformer winding .At APSCL, short-circuit protection are given using-

- (I) Differential relay
- (II) Buchholz relay.

4.6.1.1 Differential Relay:

Different relay are recommended for the 1 MVA and above rated transformer. Differential relay must not operate on external fault. This type of relay is used to identify internal fault .The relay will be operate only for the selected zone. There are two current transformers (CT) connected to the two end of the protected zone. When difference between two CT's current more than zero then the operating coil sense the current and relay will be operate.

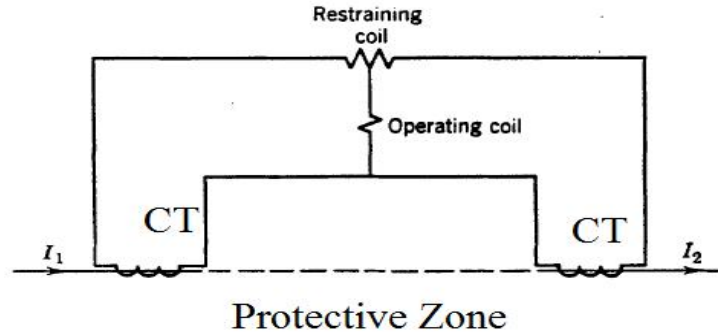

Figure 4.14: Differential relay.

4.6.1.2 Buchholz Relay:

Buchholz relay are used for 500 KVA to 700 KVA rated transformer. A Buchholz relay is a gas and oil operated device. This type of relay is connected between the top of the transformer main tank and the conservator. The function of the relay is to detect an abnormal condition of the tank. It operates with two stages. At first stage it sent an alarm and at second stage it trips the circuit breaker.



Figure 4.15: Buchholz relay.

4.6.2 Oil Temperature Indicator (OTI):

At the top of the transformer we have an oil tank. The oil of this tank is used for cooling and insulation purpose of the transformer. When transformer is in load then this oil temperature increases. This temperature has some limitations .If temperature crosses its limit, then the

indicator will operate. OTI works in three stages; at first it starts the cooling operation of transformer. If the temperature of oil increases then OTI gives an alarm and at last it trip the circuit breaker.

4.6.3 Pressure Relay Device (PRD):

PRD controls the operating gas pressure of the transformer. It gives a signal for sudden increase of gas pressure with respect to the operating pressure on the transformer. A PRD relay operates in three to four cycle on a 60 Hz circuit when gas pressure of transformer rises 5.5 psi per second. At high rates of rise: 30 to 40 psi per second, it will operate in a half cycle. It will not operate for normal gas pressure changes of transformer. When an abnormal gas pressure changes operation occurs, relay will keep the alarm and trip circuit breaker.

4.7 Cooling System of Transformer:

Capacity of a transformer can increase by increasing the cooling system of transformer. Excessive temperature rise in any portion of the transformer. For this reason, working parts of large transformers are usually submerged in high-grade insulating oil. In a transformer there has a arrangement for free circulation of oil through the core and coil. This oil can be heated by sun light and other moisture. Several methods have been developed for removing heat which is transmitted to the transformer oil from the core and windings

- Oil Filled Self Cooling
- Forced Air and Forced Oil Cooling

4.7.1 Oil Filled Self Cooling:

In this system the cooling take place by the direct radiation from the tank of surrounding air. Here transformer provides a greater radiating surface. Oil in contact with the core and windings rises as it absorbs heat and flows outward and downward along tank walls, where it is cooled by radiating heat to the surrounding air. Transformers may have external radiators attached to the tank to provide greater surface area for cooling.



Figure 4.16: Transformer radiator for oil filled safe cooling.

4.7.2 Forced Air Cooling:

Forced-Air-cooled Transformers have fan-cooled radiators through which the transformer oil circulates. Fans force air through radiators cools the oil. This type of cooling is also provided for dry type transformers. The air is forced on to the tank surface to increase the rate of heat dissipation. The fans are switched on when the temperature of the winding increases above permissible level.



Figure 4.17: Forced air cooling system of transformer.

4.8 Bas-bar Protection:

The protection system for a power system should cover all probable types of fault. Busbars has an important role in power transmission and distribution. Bus-bar is the main connecting point between feeder and distribution line. So bus-bar should protect and isolate from large fault before fault spread over the whole system and causes great damage and long shut down. Many type of protection system may be used for bus-bar. APSCL uses some important protection for protect its bus-bar those are

- Differential Protection
- Over Current protection
- Frame-earth protection
- Phase comparison protection

Those types of protection are controlled by the control unit of substation using relay.

4.9 Transmission Line Protection:

Transmission line is the main component of the distribution system. APSCL uses 230 KV and 132 KV transmission line for its distribution. Both type of transmission line are three phase. For protection individual's line, APSCL uses:

- Distance protection
- Directional Earth fault protection

4.9.1 Distance Protection:

Transmissions lines are made by conductor. Conductors have a resistance and impedance. Distance relays, are used for impedance measurements in order to determine the presence and location of faults.

Impedance $Z = V \div I$

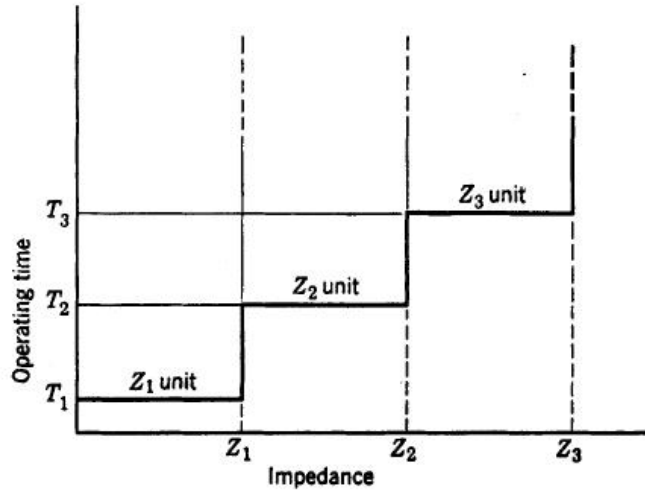

Figure 4.18: Transmission line distance protection.

When fault will occur then the voltage will decrease and current will increase. Using this equation distance relay can identify the faulty zone and also calculate the fault time.

4.9.2 Directional Earth Fault Protection:

Mainly the 132KV and 230 KV transmission lines of APSCL are protected by distance protection relay but directional earth fault protections are given for back up. In directional relay -

Impedance $Z \sin \tau = (V \div I) \sin$

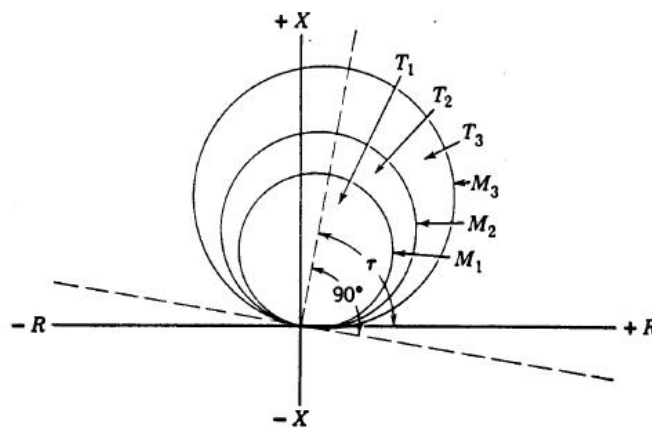

Figure 4.19: Directional earth fault protection.

Depending on the angle between voltage and current the relay can identify magnitude and direction of fault.

4.10 Danger switch:

A power plant must have to be a protective area. Probable protection should be taken there. If any kind of danger occurs then danger switch may be used for instant shut down of any instrument of a plant. Danger switches of APSCL are external keys of lock system.



Figure 4.20: Danger switch.

4.11 Protection Control Room:

At APSCL there have control rooms for every unit, in which actions can be taken to operate the plant safely under normal conditions and to maintain the generator in a safe condition during accident situations. It encompasses the instrumentation and controls necessary for a safe shutdown of the plant and typically includes the critical document reference file, the computer room ,shift supervisor's office, the operator wash room and kitchen, and other critical areas to which frequent personnel access or continuous occupancy may be necessary in the event of an accident.



Figure 4.21: Control room at APSCL.

4.12 Conclusion:

For getting the constant electricity from a power plant protection is necessary. This chapter highlights about the protection system which is a very important for generator, transformer, busbar, transmission line boiler etc. Maximum protection systems are automated, some are operated manually.

Chapter 5

5 SUBSTATION

5.1 Introduction:

APSCL transmits power to the national grid because of this reason APSCL requires a substation to transmit its power in the national grid. APSCL substation is an outdoor type substation which steps up its generating voltage from 15.6KV to 132KV and to the 230KV to be supplied into the bus bar. The installation capacity of the APSCL is 724MW and the efficiency of this power plant is 29.01.

Power is generated at the power plant. After generation power has to be supplied to the user. This can be possible with the help of substation and transmission lines because most of the generator gives low voltage output approximately 15.6KV as a result at the generating state current has a high amplitude of approximately 2000A. If the transmitting current has a high amplitude at transmitting state then line loss (I^2R) will increase. So it is not economically profitable to transmit power in the conductor. That's why we need to step up the voltage at a higher level to transmit it. In a substation, on the generating state voltage is stepped up at a certain amount. On the other hand power plant needs some auxiliary power. Most of the times these power come from other power plant through transmission line. As a result we also need a substation to step it down for auxiliary use.

These sections are described by Noor Mohammed in 2nd, 3rd and 4th January 2012 from 8am to 4pm, 7 hours each day. In total we have completed 21 hours in those 3 days.

5.2 Overview of Power Generation, Transmission and Distribution:

Power generates from power plant at a low voltage. As a result to minimize the power loss we have stepped it up for transmission. This job is done by generating substation. After that it has to be sent to the terminal station. At the terminal station power steps down at a low voltage level (e.g. 33KV, 11KV). Different industry which needs a large amount of power finds out its

connection from this line. Then it steps down again at zonal substation. Till zonal substation the connections comes through delta connection. On zonal substation there have distribution transformer. The input of distribution transformer is 33KV or 11KV dell connection. The Output of the distribution transformer is 220V (L-n) y connected. From this line connection goes towards general consumer.

From the figure bellow we will observe an overview of power generation, Transmission and distribution system.

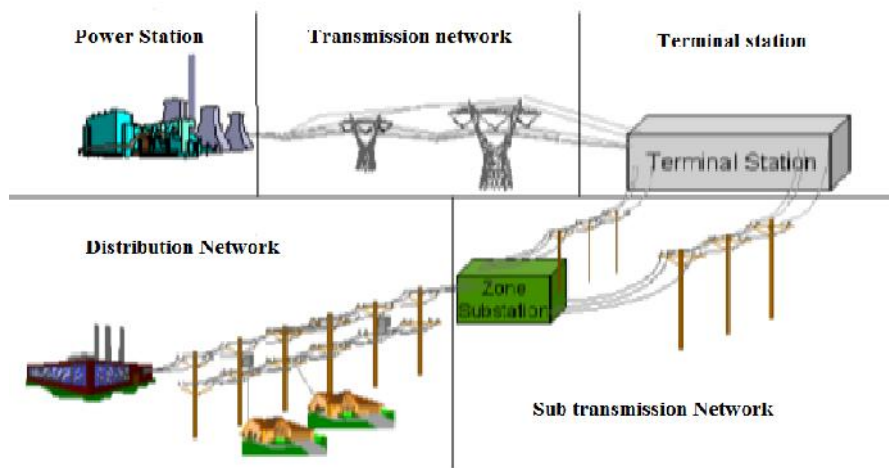

Figure 5.1: Distribution asset in national network.

5.3 Voltage Classes of APSCCL:

Power equipment is normally rated according to the nominal system voltage. In equipment terminology, the voltage ratings fall into four classes:

- Low voltage - 600 V or less.
- Medium voltage - above 600 V to 72KV.
- High voltage - above 72KV to 242KV.

5.4 Grid Voltage and Distribution Voltage of APSCCL:

Grid Voltage: The voltage level at which the transmission lines conducts from a substation is known as Grid voltage.

The APSCCL transmitting grid voltage is 132KV and 230KV.

5.5 Distribution Voltage:

The voltage level at which a distribution substation distributes its voltage for user is known as distribution voltage.

Distributing voltage level of APSCCL substation: 33KV, 11KV, 600V and 400V.

This all voltage levels are used for internal backup purpose of APSCCL power station.

5.6 Generating Profile of APSCCL:

Steam Turbine Generator:

Table 5.1: Steam turbine generator.

| Steam turbine unit | Generating voltage | Capacity | Grid voltage |
|--------------------|--------------------|----------|--------------|
| UNIT 1 | 11KV | 64MW | 132KV |
| UNIT 2 | 11KV | 64MW | 132KV |
| UNIT 3 | 15.75KV | 150MW | 230KV |
| UNIT 4 | 15.75KV | 150MW | 230KV |
| UNIT 5 | 15.75KV | 150MW | 230KV |

Combined Cycle Power Plant (CCPP):

Table 5.2: Combined cycle power plant.

| CCPP | Generating voltage | Capacity | Grid voltage |
|---------|--------------------|----------|--------------|
| UNIT 1 | 13.8KV | 56MW | 132KV |
| UNIT 2 | 13.8KV | 56MW | 132KV |
| ST UNIT | 13.8KV | 34MW | 132KV |

5.7 System Components:

This chapter provides information regarding the requirements and the application of major apparatus used in APSCL substation.

The major system components which we observed at APSCL substation described in this chapter are:

- ❑ Transformers.
- ❑ Isolators.
- ❑ Power Circuit Breakers.
- ❑ Earthing Switch.
- ❑ Lightning arrester.
- ❑ Relay
- ❑ Automatic Circuit Recloser.
- ❑ Power Capacitors.
- ❑ Bus Bar.
- ❑ Insulator.
- ❑ Transmission line.
- ❑ Wave Trap.

5.7.1 Transformer:

In APSCL substation we have observed several transformers. These are:

- ❑ Power Transformer.
- ❑ Potential transformer.
- ❑ Current transformer.
- ❑ Unit Transformer.
- ❑ Intermediate potential transformer.

A brief description is given bellow.

5.7.1.1 Power Transformer:

An iron-core transformer having a primary winding that is connected to an alternating-current power line and one or more secondary windings that provide different alternating voltage values and it deals with a large amount of power (at MW range) is known as power transformer.



Figure 5.2: Tap changing power transformer.

Different part of power transformer:

Radiator:

Radiators are used in a transformer to cool the transformer oil through natural air or forced air flowing in these radiator fins. As the transformer oil temperature goes down due to cooling it goes to the transformer tank from bottom, cool the windings and gets heated, and then returns to the radiator for next cooling. This cycle repeats as the oil flow is also natural due to difference in temperature of oil on bottom and top. In big power transformers this oil circulation is forced by oil pumps for effective cooling. The radiator has many small fins and there are 4-10 radiator banks in a transformer depending on capacity and make of the transformer.



Figure 5.3: Radiator of a power transformer.

Breather:

When transformer undergoes load changes, there will be a volumetric expansion and contraction of oil. When the oil undergoes contraction, transformer breathes air into the conservator tank. To avoid moisture and dirt entering into tank, breathers are provided with silica gel crystals.



Figure 5.4: Breather of a power transformer.

Bushing:

The bushing is the structure used to insulate the current-carrying parts from ground and from other live parts. It has a through conductor for carrying current from the line connection to the contacts. Bushings for transformer are normally made of a porcelain or glass outer shell with an internal insulation material of paper, oil, compound, ceramic materials, or a combination of these. Bushing is connectors by which a conductor can be connect with the transformer.



Figure 5.5: Bushing of power transformer.

5.7.1.2 Potential Transformer:

Potential transformer is a transformer which steps down the voltage for measurement and protection. Voltmeter, Mega wattmeter, Mega varmeter are typical example of instruments used the secondary voltage of the potential transformer. The output of the secondary of the potential transformer is always 110V. Primary of the PT is always connected at the high voltage and the secondary of PT always connected to the low range voltmeter coil of the relay at the control room. One end of the secondary of PT always has to ground for the safety purpose.



Figure 5.6: Potential transformer with nameplate of the APSCL substation.

Table 5.3: 132 kV Single phase outdoor type potential transformer.

| | | |
|-------------------------------|----------------------------|----------------------|
| Rated voltage | 132 kV | |
| Construction | Out door | |
| No. of phase | Single | |
| Ratio | $(132000 / 3) / (110 / 3)$ | |
| Burden | 60 VA | |
| Serial no. | 132 P.S. | |
| Highest system voltage | 145 kV | |
| Insulation level | 275/650 kV | |
| Rated frequency | 50 Hz | |
| Total weight | 600 Kg | |
| Class of accuracy | 0.2 | |
| Years of manufacturing | 2009 | |
| Ratio | Primary Connection | Secondary Connection |
| $(132000/1.73) / (110/1.73)$ | A-N | a-n |

5.7.1.3 Current Transformer:

The large alternating current which cannot pass through normal ammeters and the current coils of the wattmeter's, energy meters can easily be measured by current transformers along with normal low range instruments. The secondary rated current of the CT is 5A. It is designed to provide a current in the secondary winding which is proportional to the primary winding current. Basically most of the protective relays input are current. That's why we need current transformer at the switchyard.

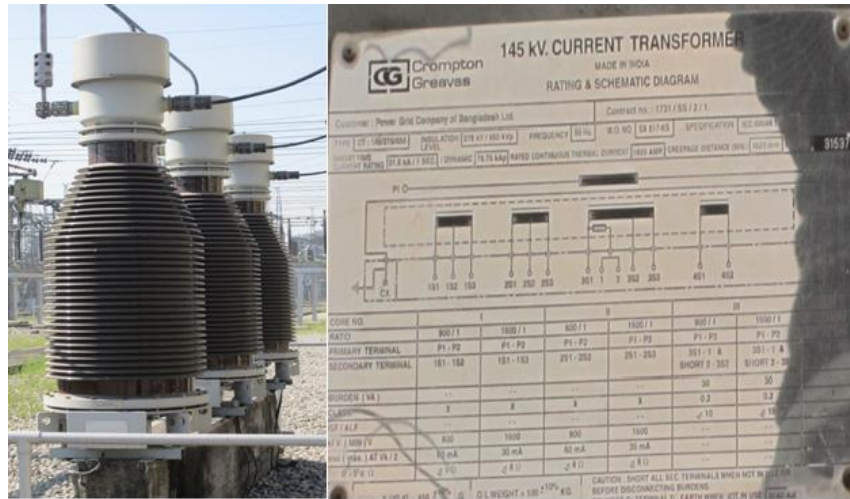

Figure 5.7: Current transformer with nameplate of the APSCL substation.

5.7.1.4 Unit Transformer:

Unit transformer are step up transformer which is connected to generating house & step up voltage from 11/15kV voltage to 132/220kV voltage level as requirement or line designs.



Figure 5.8: Single phase unit transformer.

It is just like other transformers but connected to unit of the generating house that's why we called it unit transformer.

In the figure we can see an on load tap changing unit transformer which transforms the voltage at 15KV to 132KV. We observed this type of transformer on the outside of the generator room of the steam turbine unit.

5.7.1.5 Intermediate Potential Transformer:

This type of transformer transforms the voltage from 132KV to 230KV or 230KV to 132KV which depends upon load.



Figure 5.9: Intermediate potential transformer.

5.7.1.6 Maintenance of Transformer:

Transformer is the basic element of the substation. So for avoid dangerous fault on the substation APSCL has to maintenance transformer for usages within certain period. Transformer maintenance procedures are divided into the Following service classifications in APSCL:

Distribution Transformers:

- ❏ Check all the overhead connections monthly.
- ❏ Check oil level annually.
- ❏ Check the bushings for cracks or loose contacts annually.

- ✘ Obtain oil sample and perform lab tests for dielectric strength, neutralization number, interfacial tension, and gas-in-oil analysis every two years.
- ✘ Substation Transformers:
- ✘ Check all the overhead connections monthly.
- ✘ Obtain oil sample and perform lab tests for dielectric strength, neutralization number, interfacial tension, and gas-in-oil analysis annually.
- ✘ Check the bushings for cracks or loose contacts annually.
- ✘ Check the connections of incoming and outgoing overhead/underground conductors of the bushing by annually.
- ✘ Check the service transformer connection annually.
- ✘ Check the fuses on the high side and the low side annually.
- ✘ Check the current and potential transformers and the disconnect switches for manual operation annually.
- ✘ Check the transformer tank, cooling fins, tubes, radiators, and other openings visually for any possible leaks monthly.
- ✘ Check the gauges on the transformer for oil level, oil temperature, and tank pressure weekly. Look for signs of overheating or corrosion.
- ✘ Observe any change in operating sound regularly. A louder hum than normal could indicate low oil level or temperature rise inside the tank.

5.7.2 Isolator:

Isolator is a switch which does not consists of an arc extinction mechanism. Isolator have to always on or off at off load condition. Basically isolator is used for the maintenance purpose of the line in APSCL substation. Circuit Breaker will trip instantly if a fault occurs on the line. After that first of all we have to isolate the line by isolators and then we have to do maintenance work.

Isolator can be in three types:

- ✘ Horizontal type (These types of isolator isolate the line horizontally)
- ✘ Pantograph type (Isolates the line with vertical collapsible conductor)

- ❏ Vertical type (Isolates the line vertically)

In APSCL we have seen only Horizontal Centre Break Type Isolator.



Figure 5.10: Horizontal center break isolator from APSCL.

In the picture we can see a Horizontal Centre Break Type Isolator. This isolator is used at unit 3. In the picture we can see that it is now at open state because unit three was off at that time when we visited that place.

5.7.3 Power Circuit Breaker:

Whenever a fault occurs on a power system then the part of the system must be isolated from the healthy part of the system. This function is accomplished by circuit breaker. Thus a circuit breaker can make or break the circuit either manually or automatically under different conditions such as no load, Full load, and short circuit. On the other hand we can say a circuit breaker is a switch which contains arc extinction mechanism.

In APSCL we have seen two types of circuit breaker:

- ❏ Minimum oil Circuit breaker.
- ❏ SF6 circuit breaker.

5.7.3.1 Minimum Oil Circuit Breaker:

A minimum oil circuit breaker uses a small container having oil which is just enough for arc extinction. The container of oil is supported on porcelain insulators, so that required insulation

can be obtained for live part from earth. On the other hand minimum oil circuit breaker needs less space than bulk oil circuit breaker.

As an interrupting medium, oil is much better than air at room pressure. Its dielectric strength is greater and, in addition, the arc generates hydrogen gas from the oil which helps to cool the arc. The use of a small arcing chamber to build up pressure greatly increases the interrupting capacity of an oil circuit breaker. The major disadvantages of oil circuit breakers are their relatively high cost.

For that case the current carrying conductors are submerged by oil. When fault occurs then the conductors are start to being separate and arcs are spread out. As the conductors are submerged by the oil so oil behaves like an insulator for the arc.



Figure 5.11: Minimum oil CB.

In the picture we can see a minimum oil circuit breaker. On the picture we can see the oil tank at the bottom of the breaker.

5.7.3.2 Maintenance of Minimum Oil Circuit Breaker:

The maintenance of oil CB consists of checking of contacts and the dielectric strength of the oil. After fault has been interrupt by CB, fault current flows for short time or load currents for

sometimes it's a resulted contacts may be burnt due to arcing. Also there may be some loss of dielectric strength due to carbonization. This will reduce rapturing capacity of the breaker. That's why periodic checking of circuit breaker is essential after regular interval of three or six months. Following points should be kept in mind while checking:

- We have to check the current carrying parts. If they are burnt then we have to replace them.
- We have to check the dielectric strength of oil. If the color is changed then it should be changed or reconditioned. The oil in good condition withstands 30KV for one minute with 4mm gap between electrodes.
- We have to check the insulation for any damage.
- We have to check the oil level.
- We have to check the closing and opening mechanism regularly.

5.7.3.3 SF6 Circuit Breaker:

SF6 Circuit breaker is a switch which uses sulfur Hexafluoride gash for arc extinction. SF6 gash has an arc extinguishing property. It is a highly electronegative gash which has a strong tendency to absorb free electron. It is used for high voltage and extra high voltage application.

In general, the SF6 circuit breakers consist of two main parts, the poles and the mechanism. The poles consist of contact and arc-extinguishing devices. The mechanism is the part to open or close the contacts in the poles at the same time instantaneously (with max. 5 millisecond tolerance). The closing and opening procedures are performed through springs which are charged by a servomotor and a driving lever. In the system, the closing springs are first charged. If "close" button is pressed the opening springs get charged while the contacts get closed. Thus, circuit breaker will be ready for opening. The mechanical operating cycle of the circuit breaker is (OPEN-3 Min CLOSE/OPEN-3 Min CLOSE/OPEN) or (OPEN-0.3 sec-CLOSE/OPEN-3 Min CLOSE/OPEN). The second cycle is valid when the circuit breaker is used with re-closing relay. In that case, after the closing operation, the closing springs are charged by the driving lever or by driving motor (if equipped). Thus, the circuit breaker will be ready for opening and re-closing.



Figure 5.12: SF6 circuit breaker.

5.7.4 Earthing Switch:

In substation trap charge may exist in lines. For maintenance purpose the trap charges required to be grounded by earthing switch. Earthing Switch is connected between the line conductor and earth. Normally it is open. When the line is disconnected, the Earthing switch is closed for discharge voltage trapped on the line.



Figure 5.13: Earthing switch used in 132KV line.

Operating sequence for maintenance purpose:

While Opening:

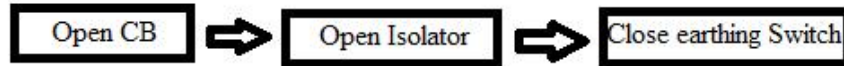

While Closing:

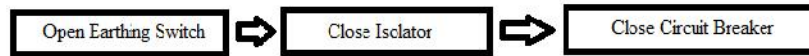

5.7.5 Lightning Arrester:

The device that is used to protect the line from lightning impulse voltage is known as lightning arrester. Basically lightning arrester creates a low resistance path for the lightning impulse voltage.

We observed two types of lightning arrester in APSCL substation:

- Rod gap lightning arrester
- Horn gap lightning arrester

5.7.5.1 Rod Gap Lightning Arrester:

This type of lightning arrester has two rod with a given gap. One rod has to be connected with the main line and the other one is connected to ground. That means that it is parallelly connected to the main line. When lightning occur an arc between the gaps is created and as a result it will be shorted to ground. And the lightning impulse voltage will go to ground through it. We saw this type of lightning arrester on the top of the transformer of steam turbine unit of APSCL substation.



Figure 5.14: Rod gap type lightning arrester of APSCL.

5.7.5.2 Horn Gap Lightning Arrester:

These types of lightning arrester contain a 1.4mm horn gap. When lightning occurs arc is generated between the horn gaps and hence it will be shorted and grounded the lightning stroke.



Figure 5.15: Horn type of lightning arrester.

5.7.6 Relay:

Relay is a sensor which senses the abnormal condition and transmits signals for circuit breaker. A small current energizes the relay, which closes a gate, allowing a large current to flow through.

The relays we have visited in APSCL substation control room are:

5.7.6.1 Electromagnetic Attraction Type of Relay:

The electromagnetic attraction type of relay operate on the principle of attraction of an armature by a magnetic force produced by undesirable current or movement of plunger in solenoid. These relay operates in both AC and DC.

5.7.6.2 Induction Type Relay:

These relay works on the electromagnetic induction principle. These relay only can use for AC purpose. It consists of an electromagnetic system which operates on a moving conductor, generally in the form of a disc or cup, and functions through the interaction of electromagnetic fluxes with the parasitic Fault currents which are induced in the rotor by these fluxes. These two

fluxes, which are mutually displaced both in angle and in position, produce a torque for the tripping mechanism.

5.7.6.3 Directional Type of Relay:

These relay works on the direction of current or power flow in the circuit.

Directional relay can be in two types:

- **Reverse Current Type:** these relay operates when the current flows at the reverse direction.
- **Reverse Power Type:** These relay operates when the power flows on reverse direction.

5.7.6.4 Distance Type Relay:

These relay works on the principle of measurement of voltage to current ratio.

Distance relay are in three types:

- Impedance type relay.
- Reactance type Relay.
- Admittance type relay.

Impedance, Reactance and admittance types of relay are used to calculate the distance of the fault.

5.7.6.5 Differential Type of Relay:

The differential relay operates when the vector difference between two or more electrical quantities in the circuit in which relay is connected. When this exceeds a set value then relay operates. These are classified as:

- Current differential relay.
- Voltage differential relay.

5.7.6.6 Over Voltage, Current, Power Relay:

These relay operates when the voltage, current, power in a circuit raise above a set value.

5.7.6.7 Under Voltage, Current, and Power Relay:

These relay operates when the voltage, current, power in a circuit falls below a set value.

5.7.7 Automatic Circuit Recloser:

An automatic circuit recloser is a circuit breaker equipped with a mechanism that can automatically close the breaker after it has been opened due to a fault.

5.7.8 Power Capacitors:

Power capacitors are used to improve the power factor. At APSCL the power factor is 0.8.

5.7.9 Bus Bar:

Bus bar is an electrical conductor linking all generators and/or batteries and distributing power to all operative branches. It is essentially a metallic bar used to carry a large current and to make common connections between several circuits. In APSCL we have seen two double line bus bars. One of them was for 132KV and the other is for 230KV.



Figure 5.16: 132KV double circuit bus bar.

Double line Bus bar is used for safety purpose. For that case one bus bar always remains active and the other one will be standby. If any fault occurs on the active bus bar then the standby bus bar will be active with the help of Bus coupler.

5.7.10 Insulator:

Transmission line contains high voltage. So the high voltage carrying conductor cannot touch the transmission pole. So insulator is used to connect the transmission line onto the pole.

In APSCL we have observed two types of insulator:

- ❑ Pin type insulator
- ❑ Suspension type insulator.

5.7.10.1 Pin Type Insulators:

Pin type insulator is basically used for low voltage distribution line isolation purpose. Current carrying conductor cannot touch the tower. If it touches the tower then tower will also conduct the current. As a result insulators are used to isolate the tower from conductor.



Figure 5.17: Pin type insulator for 33KV line.

5.7.10.2 Suspension Type Insulator:

This type of insulator is used at high voltage transmission line isolation. For that case the insulator contains several numbers of disks. The number of disk will be determined by the voltage ratings of the transmission line.



Figure 5.18: Suspension type insulator observed from APSCL substation.

Now we will see how the number of disk of this insulator is related with the voltage ratings of the transmission line.

Table 5.4: Insulators voltage level with its number of disk.

| Voltage Level | Number of disk |
|---------------|----------------|
| 11KV | 2 |
| 33KV | 3 |
| 132KV | 11 |
| 230KV | 17 |

5.7.11 Transmission Line:

The electrical transmission system is more complex and dynamic than other utility systems, such as water or natural gas. Electricity flows from power plants, through transformers and transmission lines, to substations, distribution lines, and then finally to the electricity consumer the electric system is highly interconnected. Basically the connection between Bus bar and the zone substation is known as transmission line.

The interconnectedness of the system means that the transmission grid functions as one entity.

5.7.11.1 Two High Voltage Double Circuit Transmission Lines observed in APSCCL:

This type of transmission line contains two set of three phase dell connected high voltage transmission line.



Figure 5.19: High voltage double circuit transition line.

In picture we can see two high voltage double circuit transmission lines. Here we can see two double circuits go through the two side of the pole. On the top of the three phase transmission line we can see two extra lines. These are used for arrest the lightning. Here we can see the suspension type of insulator is used. If we count the disk on the insulator then we can see there have 17 disks. That means it is a 230KV transmission line. Weather it is 132KV transmission line then we can see there have only 11 disks.

5.7.11.2 Different Transmission Line Pole Structure:

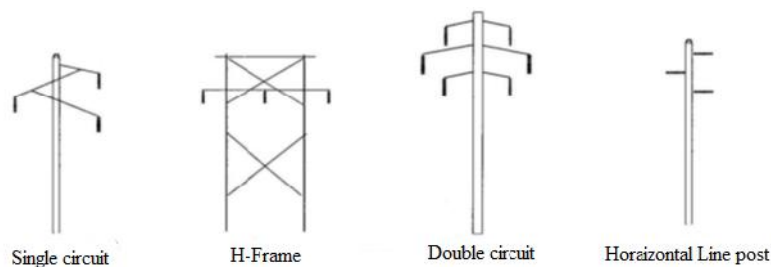

Figure 5.20: Pole structure of transmission line.

Single circuit, H-Frame and Horizontal line post type poles contain one set of transmission line and the double circuit type pole will contain two sets of transmission line.

In APSCL we observed only double circuit.

5.7.12 Wave Trap:

Line trap also is known as Wave trap. What it does is trapping the high frequency communication signals sent on the line from the remote substation and diverting them to the telecom/teleportation panel in the substation control room (through coupling capacitor and LMU). This is relevant in Power Line Carrier Communication (PLCC) systems for communication among various substations without dependence on the telecom company network. The signals are primarily teleportation signals and in addition, voice and data communication signals. Line trap also is known as Wave trap. What it does is trapping the high frequency communication signals sent on the line from the remote substation and diverting them to the telecom/teleportation panel in the substation control room (through coupling capacitor and LMU). This is relevant in Power Line Carrier Communication (PLCC) systems for communication among various substations without dependence on the telecom company network. The signals are primarily teleportation signals and in addition, voice and data communication signals.

The Line trap offers high impedance to the high frequency communication signals thus obstructs the flow of these signals in to the substation busbars. If there were not to be there, then signal loss is more and communication will be ineffective/probably impossible.

At previous day wave trap was used for substation to substation communication.

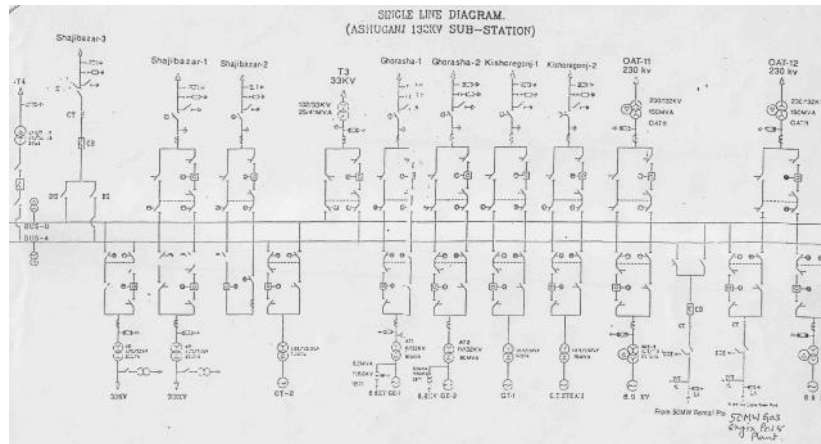

Figure 5.21: Wave trap used on APSCL substation.

5.8 Single Line Diagram:

Single sine diagram is graphical representation of electrical circuit drawn using single line instead of drawing 3 separate lines for three phases.

Single Line Diagram for 132KV Substation of APSCL:



From this 132KV single line diagram we can see from APSCL substation 3 feeder goes to the shajibazar substation, two feeders at ghorashal and another two feeders goes towards kishoreganj substation.

Single Line Diagram for 230KV Substation of APSCL:

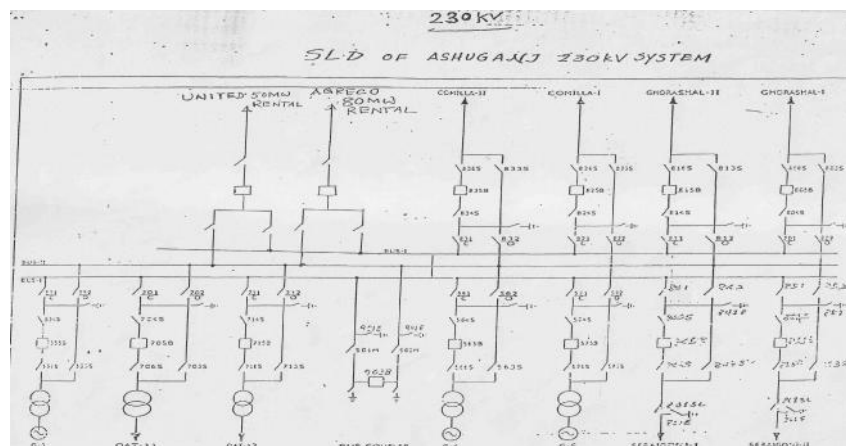

At the top of the single line diagram we can see the outgoing feeder from APSCL substation. Here we can see two feeders go towards comilla and other two goes towards ghorashal. Another

two feeder goes towards AGRECO (80MW Rental power plant at ASHUGANJ) and the UNITED (50MW rental power plant at ashuganj).On the bottom side we can see the generating profile of APSCL substation.

5.9 DC Battery and Battery Charger Room:

In APSCL Battery is used for auxiliary power sources of the substation. As most of the control equipment of the substation runs on DC so Battery is the only back up source of DC supply. Without DC power supply, the grid is unprotected, because security lighting, fire alarm circuit, breaker control circuit, heating equipment and relay get energized by the DC supply. In the station, they have a battery charger room and there were 84 nickel cadmium battery cell.



Figure 5.22: Dc battery room of APSCL substation.

5.10 Control Room:

The APSCL substation control room contains switchboard panels, batteries, battery chargers, supervisory control, power-line carrier, meters, and relays. The control house provides all weather protection and security for the control equipment.



Figure 5.23: Rectifier used for battery charging purpose.

This is the rectifier of the control room which converts the AC current into DC. This Rectifier is used for battery charging purpose. Battery always has to be charged by a DC current. That's why this Rectifier is used on APSCL control room.

5.11 Cables:

A cable is defined as a single conductor or an assembly of conductors covered by solid electrical insulation. In APSCL substation we observed different types of cables. The name and their usages specification are given bellow.

Table 5.5: : Different Cables Used at APSCL Substation.

| Cables | Usage rating |
|-------------------|-------------------|
| PVC | 400V to 11KV |
| XLPE | 33KV to 230KV |
| Bear Conductor | Low densely area |
| Underground cable | High densely area |

5.12 Brief Discussion of a Single Feeder:

After generating electricity by generator it is necessary to send it towards user. The setup by which we send electricity till its user is known as feeder.

The output voltage and current ratings of the generator of APSCL is 15.6KV and 4000A. We know that if the current rating of the conductor increase then the size of the conductor will also

increase. 4000A is a huge amount current for the conductor. To conduct that amount of current a conductor with big diameter comes to the unit transformer from generator room.



Figure 5.24: Conductors which contains 4000A current.

In the picture here we can see the conductor with large diameter which comes from generator room to the top of the transformer. These conductors will be connected to the primary bushing of the single phase unit transformer.



Figure 5.25: Primary bushing of a single phase unit transformer.

In the picture we can see the primary bushing of a single phase unit transformer. This unit transformer is used at unit three of steam engine.

Here this transformer converts the voltage from 15.6KV to 230KV.



Figure 5.26: Output bushing of the single phase unit transformer.

The output bushing of the transformer is connected on the switchyard with an underground cable.



Figure 5.27: Typical 230KV feeder for unit three.

From the picture the most left row of the pole is known as insulator row. From 230KV transformer output, the underground cable connects with this insulator row. In the row there have three isolators one of them can be shown in the picture and the rest two is not in the picture. Here three phases connects with these three isolators. The next row also contains three insulators. From these row connections comes to the PT row. At that row there have three potential transformers for three phases. The middle PT is on the pole and the rest of two PT are on the ground. Then connections come at CT row. There have three CT for three phases. The output of CT and PT goes to the relay at control room with an underground cable. Then the next row is for Isolator. At that row there have also an earthling switch. And the next row is for circuit breaker.

They are minimum oil CB. There have a box for this CB which contains oil. After that row there have an Isolator row. There also have three isolators for three phases. From this isolator the connection is directly goes to 230KV bus bar.



Figure 5.28: 230KV Double circuit bus bar.

From the isolator we can see three wires are connected with the bus bar. Here three wires are for the three phase. From this bus bar different transmission lines goes at different place.

5.13 Flow Diagram of a Single Feeder of APSCL Substation:

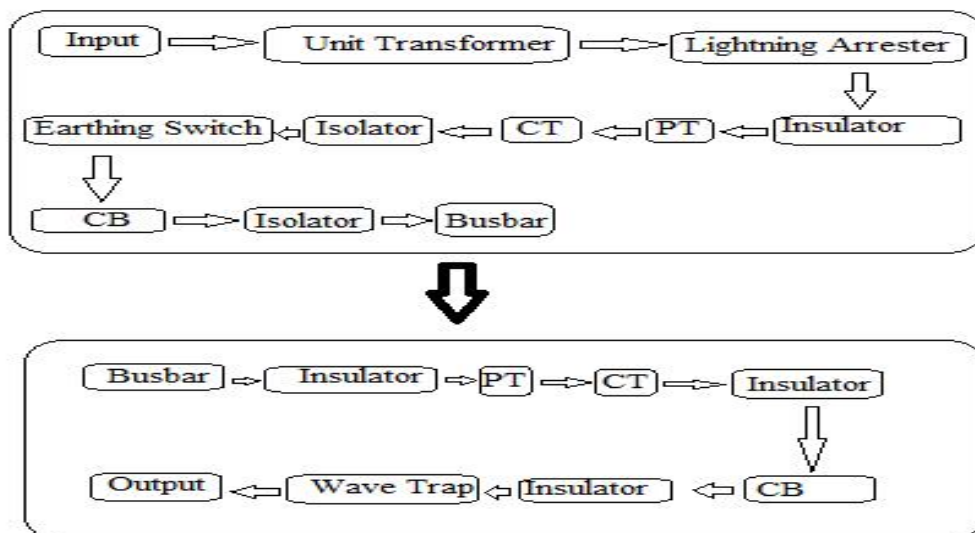

Here in this flow diagram the input is the generator room and Output is the transmission line.

5.14 Conclusion:

Substation is an essential element on a power plant. Substation is primarily responsible to distribute power to the consumers. Most of the generators generate a low output voltage with a higher current. Through power transformer that voltage is step up to require voltage level. By the arrangement discussed before, power gathers at the bus bar. Through bus bar voltage is distributed to the transmission line system. In support of distributing the power to the grid and in favor of ensures the protection of substation and its equipment's are essential. Inside this report functions of equipment's exists in substation like transformers, relays, breakers are all explained. From this report I tried to make an overview of APSCL substation

Chapter 6

6 Problems and Recommendations:

In the process of this intern and also in writing the report we faced some problems and we also like to have some recommendations for solving those and making the intern more effective to students.

Problems:

1. We can't have proper freedom to collect all information because of APSCCL internal rules.
2. Taking snaps of different areas was not allowed in some places inside APSCCL.
3. Most of the engineers in APSCCL were very busy, we have to stay with them until they become free from their work.
4. Some of us don't have sufficient knowledge about power plant because of not completing some courses, which create a big problem for them.
5. Proper management of this intern was not perfectly scheduled by the APSCCL.

Recommendations:

1. Student should complete power plant related courses before going to intern.
2. Time period of intern should be more, because then student can have more time to understand the plant.
3. Snap taking should be more relaxed for the intern student.
4. Movement inside the switch yard should be more flexible for the student.

Chapter 7

7 Conclusion

APSCL is the second leading power station company of Bangladesh. Its strategic aim is to strengthen the leading position and to ensure continued growth which leads it to be the leading power generating company in Bangladesh. For Electrical and Electronic Engineering student of East West University APSCL could be considered as a very good place to gain practical knowledge. We are grateful that we got the opportunity to see the practical work at APSCL which we learned theoretically from the University.

In our internship period at APSCL we got lot of knowledge about the power generation system, protection system and distribution system of plant. In future this knowledge will give us confidence to face the interview to any power sector. Authority of APSCL also provides us a favorable environment and encouraged us to co-operate with each other.

Chapter-8

8 References:

- 1) http://www.apscl.com/Board_of_Directors.asp
- 2) http://www.daviddarling.info/encyclopedia/I/AE_impulse_turbine.html
- 3) http://firecontrolman.tpub.com/14104/css/14104_78.htm
- 4) http://engineering.wikia.com/wiki/Power_plant_furnace
- 5) <http://www.wisegeek.com/what-is-a-superheater.htm>
- 6) http://www.draxpower.com/explore_drax/power_station/?id=1893
- 7) http://en.wikipedia.org/wiki/Thermal_power_station#Reheater
- 8) <http://www.steamlocomotive.com/appliances/feedwaterheaters.php>
- 9) http://en.wikipedia.org/wiki/Feedwater_heater
- 10) http://www.sterlingdeerator.com/D_Prin.html
- 11) http://en.wikipedia.org/wiki/Combined_cycle
- 12) <http://hpsweb.honeywell.com/Cultures/en-US/IndustrySolutions/Power/CombinedCyclePowerPlants/default.htm>
- 13) http://en.wikipedia.org/wiki/Gas_turbine
- 14) <http://gt-mhr.ga.com/>
- 15) <http://www.allpar.com/mopar/turbine.html>
- 16) <http://inventors.about.com/library/inventors/blenginegasturbine.htm>
- 17) <http://www.freepatentsonline.com/y2010/0242430.html>

- 18) <http://www.google.com/url?sa=t&rct=j&q=Condenser+in+CCPP&source=web&cd=10&ved=0CGkQFjAJ&url=http%3A%2F%2Fwww.freepatentsonline.com%2Fy2010%2F0024424.html&ei=RBpJT7XdHZDtrQfJ442jDw&usq=AFQjCNHKtFPmaAq9uvCIzxvIQvoSV6fJeA>
- 19) <http://www.apscl.com/>
- 20) http://en.wikipedia.org/wiki/Gas_engine

Glossaries:

Elaboration of abbreviations used in the report is given below:

APSCL= Ashuganj Power Station Company Ltd.

CCPP = combined cycle power plant.

CCGT= Combined cycle gas turbine.

MW = megawatt.

KVA= Kilo Volt Amperes.

PRD= Pressures relay Device.

OTI= Oil Temperature Indicator.

CT= Current transformer.

PT= Potential transformer

CB= Circuit breaker.

SH= Super Heater.

LP= Low Pressure.

RH=Re- Heater.

HP= High Pressure.

IP= Intermediate Pressure

IP= Intermediate Pressure.

LPH= Low Pressure Heater.

HPH= High Pressure Heater.

FD= Forced Draft.

Daily Activities:

1st Working Day: Plant Overview.

EAST WEST UNIVERSITY
 Department of Electrical and Electronic Engineering
 East West University
 EEE 499
 Industrial Training
 Daily Activity Report

Separate Daily Activity Report should be completed by each intern for every day of work and should be signed by the mentor from the company and the academic advisor. Copy of all the reports should be attached to the final internship report.

| | |
|----------------------|----------------------------------------|
| Name of the company: | APSC |
| Name of the student: | Khandker Taufiq Anwar |
| ID: | 2008-2-80-057 |
| Date: | 26-12-2011 |
| Start time/End time | 8:00AM ~ 4:00PM |
| Location: | APSC Training center, Unit-1, 2, 3, 5. |
| Mentor: | Achint Kumar Sarkar, DGM (M) |

General Instructions:

- It is the intern's duty to make sure that all his/her daily activity reports are appropriately signed by both the mentor and the academic supervisor.
- The daily report should be a brief narration of the activities during the internship period in the eyes of the intern and should be completed and submitted by every intern irrespective of the number of partners s/he might have for the presentation and final report writing purpose.
- The report should not be a compilation of lectures notes taken during the internship, rather it should depict what the intern has learned on a particular day.
- In case of any confusion, interns are strongly recommended to consult their respective academic supervisors.

EAST WEST UNIVERSITY
 Department of Electrical and Electronic Engineering
 East West University

Address the following points briefly (Use additional page if necessary)

- What was the objective of the day's activities? (If applicable, list multiple objectives)
Objectives:
 # History & development of Ashupori power station etc.
 # Visiting the plant for a basic concept about APSC.

- List the day's activities according to the order of objectives listed in 1. Mention the specifications of the equipments used/visited. Comment on how these activities fulfill your objectives.
In 1966 year decided to build APSC. First two units (1 & 2) are commissioned in 1972 with the help of German Govt. Their total capacity was 69 MW each. Now it has 8 units. Among these there is a combined cycle which consist of G.F.I, G.T & S.F. which are established in 1982 in 1986. Equipments used in APSC are mostly BBE (Germany) 1#1 (Japan) & VC (Japan), GEC (UK) & FCC (Korea). Among power plant become a joint-venture companies on 28 June 2000. Management team take over the companies from 10 June 2003. # We visit the plant. Now we have a rough idea about it where we should work in next 15 days.

- Relate your practical activity with the theoretical knowledge you gained in the respective academic course.
Today we have a idea about APSC's history & its development. Without knowing the history we can't predict the future.

26.12.11
 Signature of the mentor with date
 Name: Achint Kumar Sarkar
 Designation: DGM (M)
 Contact Phone #: 0171-425460

26.12.11
 Signature of academic supervisor with date
 Name: S.M. Shahjahan Khatun
 Designation: Lecturer

2nd Working Day: Instrument & Control Section.

EAST WEST UNIVERSITY
 Department of Electrical and Electronic Engineering
 East West University
 EEE 499
 Industrial Training
 Daily Activity Report

Separate Daily Activity Report should be completed by each intern for every day of work and should be signed by the mentor from the company and the academic advisor. Copy of all the reports should be attached to the final internship report.

| | |
|----------------------|---------------------------|
| Name of the company: | APSC |
| Name of the student: | Khandker Taufiq Anwar |
| ID: | 2008-2-80-057 |
| Date: | 27-12-2011 |
| Start time/End time | 8:00AM ~ 4:00PM |
| Location: | Steam engine unit 2, 3, 4 |
| Mentor: | Bikash Ranjan Roy |

General Instructions:

- It is the intern's duty to make sure that all his/her daily activity reports are appropriately signed by both the mentor and the academic supervisor.
- The daily report should be a brief narration of the activities during the internship period in the eyes of the intern and should be completed and submitted by every intern irrespective of the number of partners s/he might have for the presentation and final report writing purpose.
- The report should not be a compilation of lectures notes taken during the internship, rather it should depict what the intern has learned on a particular day.
- In case of any confusion, interns are strongly recommended to consult their respective academic supervisors.

EAST WEST UNIVERSITY
 Department of Electrical and Electronic Engineering
 East West University

Address the following points briefly (Use additional page if necessary)

- What was the objective of the day's activities? (If applicable, list multiple objectives)
Objectives:
 # To see different parts of burner, boiler and air & gas mixing equipment of steam turbine generator.
 # Different type of safety equipments or protective equipments.
 # Control system using PLC.

- List the day's activities according to the order of objectives listed in 1. Mention the specifications of the equipments used/visited. Comment on how these activities fulfill your objectives.
Visited: Shaughat
 # Force draft fan - To collect air from environment.
 Burner - We saw 3 burners in this unit - Babcock burner.
 Igniter - To ignite the burner.
 # Air receiver - To receive the compressed air coming from 1st of burner etc.
 Gas regulating valve - To regulate the gas supply to boiler.
 # Control - control the burner, pressure and temperature of gas.
 # Turbine - To receive the speed of boiler & give steam.
 # Flow transmitter - Shows the percentage of steam flow.
 # Pressure - Shows the % level of water.
 # Pressure safe guard - Transmits pressure level to control room.
 # Air flow transmitter - Shows the flow of air.
 # PLC - we saw different data collected from different place come to control room & auto controls the system using PLC. Most of PLC are from Allen Bradley.
 # We saw how air & gas mixing mixed. We saw three ducts from which collect air. We also saw Babcock burner & its control. We heard about the instrumentation circuit. We also saw gas management system using valves & control valves. About all this we learned in our previous course.

28-12-2011
 Signature of the mentor with date
 Name: Bikash Ranjan Roy
 Designation: Manager (I & C)
 Contact Phone #: 0172889349

28.12.11
 Signature of academic supervisor with date
 Name: S.M. Shahjahan Khatun
 Designation: Lecturer

3rd Working Day: Instrument & Control Section.

Department of Electrical and Electronic Engineering
East West University
EEE 499
Industrial Training
Daily Activity Report

Separate Daily Activity Report should be completed by each intern for every day of work and should be signed by the mentor from the company and the academic advisor. Copy of all the reports should be attached to the final internship report.

| | |
|----------------------|-------------------------------------------------------------------|
| Name of the company: | APSC |
| Name of the student: | Khandker Tauhida Inwan |
| ID: | 2008-2-80-057 |
| Date: | 28-12-2011 |
| Start time/End time | 8:00 AM ~ 4:00 PM (1:00 PM ~ 2:00 PM Int) |
| Location: | Gas distribution unit, water pump, control room, generator unit 2 |
| Mentor: | Bikash Kanyan Roy |

General Instructions:

- It is the intern's duty to make sure that all his/her daily activity reports are appropriately signed by both the mentor and the academic supervisor.
- The daily report should be a brief narration of the activities during the internship period in the eyes of the intern and should be completed and submitted by every intern irrespective of the number of partners s/he might have for the presentation and final report writing purpose.
- The report should not be a compilation of lectures notes taken during the internship, rather it should depict what the intern has learned on a particular day.
- In case of any confusion, interns are strongly recommended to consult their respective academic supervisors.

Department of Electrical and Electronic Engineering
East West University

Address the following points briefly (Use additional page if necessary)

- What was the objective of the day's activities? (If applicable, list multiple objectives)
list of the objectives:-
 # Gas & water distribution
 # To see different type of controlling cards
 # Generating unit protection for generator (steam turbine)
- List the day's activities according to the order of objectives listed in 1. Mention the specifications of the equipments used/visited. Comment on how these activities fulfill your objectives.
activities:-
 # Limiting switch - It controls the flow of gas on supply line
 # Gas meter - Counts the gas, it use hot steam from turbine to hit the gas
 # Gas heater - heats the gas, it use hot steam from turbine to hit the gas
 # Gas filter - It stops the water from flow and send to the control room
 # Gas pump - It pumps the water to the control room
 # Gas valve - It opens & closes the valve to permit water flow from control room
 # Gas control room - It controls the gas flow using differential pressure transmitter
 # Gas transmitter (water) - It measures the flow of water using differential pressure transmitter
 # Gas electronic tank - It is used to store the gas and it is used for controlling the water
 # Gas filter - It is used to filter the water using differential pressure transmitter
 # Gas valve - It is used to open & close the valve of a purpose fan
 # Drive card - It is used to open & close the valve of a purpose fan
- Relate your practical activity with the theoretical knowledge you gained in the respective academic course.
From today's visit we understand the gas & water distribution system which we learn previously. But we saw some new valves & learn some more of new pumps & their about their use. We saw some cards which helps to process the data from transmitter. We also understand these practical use in book.

Signature of the mentor with date
 Name: Bikash Kanyan Roy
 Designation: Manager
 Contact Phone #: 01712687349
 05-01-2012

Signature of academic supervisor with date
 Name: S.M. Shafiqur Rashid
 Designation: Lecturer
 19-01-12

4th Working Day: Combine Cycle Power Plant Section.

Department of Electrical and Electronic Engineering
East West University
EEE 499
Industrial Training
Daily Activity Report

Separate Daily Activity Report should be completed by each intern for every day of work and should be signed by the mentor from the company and the academic advisor. Copy of all the reports should be attached to the final internship report.

| | |
|----------------------|-------------------------------------|
| Name of the company: | APSC |
| Name of the student: | Khandker Tauhida Inwan |
| ID: | 2008-2-80-057 |
| Date: | 29-12-11 |
| Start time/End time | 8:00 AM ~ 4:00 PM |
| Location: | Gas turbine generator - 1, C.C.P.P. |
| Mentor: | Azizur Rahman |

General Instructions:

- It is the intern's duty to make sure that all his/her daily activity reports are appropriately signed by both the mentor and the academic supervisor.
- The daily report should be a brief narration of the activities during the internship period in the eyes of the intern and should be completed and submitted by every intern irrespective of the number of partners s/he might have for the presentation and final report writing purpose.
- The report should not be a compilation of lectures notes taken during the internship, rather it should depict what the intern has learned on a particular day.
- In case of any confusion, interns are strongly recommended to consult their respective academic supervisors.

Department of Electrical and Electronic Engineering
East West University

Address the following points briefly (Use additional page if necessary)

- What was the objective of the day's activities? (If applicable, list multiple objectives)
activities:-
 # Know about gas turbine generator (G.T.)
 # Gas supply & control room
- List the day's activities according to the order of objectives listed in 1. Mention the specifications of the equipments used/visited. Comment on how these activities fulfill your objectives.
*# Combustion chamber: It is the chamber where the gas & air mixture is burnt.
 # Combustion chamber: It has 10 combustion chamber.
 # Combustion chamber: It helps to cool down the hot gas.
 # Compressor: It collect air & compressed it & send it to burner.
 # Diesel engine: It is used to start the G.T. because when RPM compressor don't work.
 # Bearing system: It is used to rotate the system and its cool down oil pressure is used here.
 # Control protection: We saw the control room it's more operation.
 # Auxiliary power system
 # Control protection: If pressure or vibration increases, plant will trip.
 # Fuel system: Fuel from boiler to gas.*
- Relate your practical activity with the theoretical knowledge you gained in the respective academic course.
Now we know how a G.T. works as we know from power station course book. We also saw some mechanical devices like turbine, compressor, load oil cooler etc which we previously study.

Signature of the mentor with date
 Name: Azizur Rahman
 Designation: Assistant Engineer (IIT)
 Contact Phone #: 01712687349
 20/12/11

Signature of academic supervisor with date
 Name: S.M. Shafiqur Rashid
 Designation: Lecturer
 19-01-12

5th Working Day: Combine Cycle Power Plant Section.

EAST WEST UNIVERSITY
 Department of Electrical and Electronic Engineering
 East West University
 EEE 499
 Industrial Training
 Daily Activity Report

Separate Daily Activity Report should be completed by each intern for every day of work and should be signed by the mentor from the company and the academic advisor. Copy of all the reports should be attached to the final internship report.

| | |
|----------------------|--------------------------|
| Name of the company: | APSCCL |
| Name of the student: | Khandker Taufiqur Rahman |
| ID: | 2008-2-80-057 |
| Date: | 01-12-2011 |
| Start time/End time | 8:00AM-4:00PM |
| Location: | CCPP, GT-2. |
| Mentor: | Azizur Rahman |

General Instructions:

- It is the intern's duty to make sure that all his/her daily activity reports are appropriately signed by both the mentor and the academic supervisor.
- The daily report should be a brief narration of the activities during the internship period in the eyes of the intern and should be completed and submitted by every intern irrespective of the number of partners s/he might have for the presentation and final report writing purpose.
- The report should not be a compilation of lectures notes taken during the internship, rather it should depict what the intern has learned on a particular day.
- In case of any confusion, interns are strongly recommended to consult their respective academic supervisors.

EAST WEST UNIVERSITY
 Department of Electrical and Electronic Engineering
 East West University

Address the following points briefly (Use additional page if necessary)

- What was the objective of the day's activities? (If applicable, list multiple objectives)
objectives:
 # Visit GT-2
 # knowing about the GT equipment.

- List the day's activities according to the order of objectives listed in 1. Mention the specifications of the equipments used/visited. Comment on how these activities fulfill your objectives.
list of activities:
 # we visit GT-2 & saw different equipments.
 # DC-exciter → To create field.
 Brush commutator - its use for DC supply for motor.
 Brush less exciter - its used on GT 2 GT.
 How its rotating & how the DC star connected
 AVR - Automatic voltage regulator.
 Fuel system of GT 2
 Gas supply system & protections.

- Relate your practical activity with the theoretical knowledge you gained in the respective academic course.
we saw the implementation of theories from power station course today for combined cycle power plant.

Azizur Rahman
 01/12/11
 Signature of the mentor with date
 Name: Azizur Rahman
 Designation: Assistant Engineer (EET)
 Contact Phone #:

S.M. Shakhriar Rashid
 01.01.12
 Signature of academic supervisor with date
 Name: S.M. Shakhriar Rashid
 Designation: Lecturer

6th Working Day: Combine Cycle Power Plant Section.

EAST WEST UNIVERSITY
 Department of Electrical and Electronic Engineering
 East West University
 EEE 499
 Industrial Training
 Daily Activity Report

Separate Daily Activity Report should be completed by each intern for every day of work and should be signed by the mentor from the company and the academic advisor. Copy of all the reports should be attached to the final internship report.

| | |
|----------------------|--------------------|
| Name of the company: | APSCCL |
| Name of the student: | Md. Mizanur Rahman |
| ID: | 2007-2-80-010 |
| Date: | 01-01-12 |
| Start time/End time | 08AM-04PM |
| Location: | Combined cycle. |
| Mentor: | Azizur Rahman |

General Instructions:

- It is the intern's duty to make sure that all his/her daily activity reports are appropriately signed by both the mentor and the academic supervisor.
- The daily report should be a brief narration of the activities during the internship period in the eyes of the intern and should be completed and submitted by every intern irrespective of the number of partners s/he might have for the presentation and final report writing purpose.
- The report should not be a compilation of lectures notes taken during the internship, rather it should depict what the intern has learned on a particular day.
- In case of any confusion, interns are strongly recommended to consult their respective academic supervisors.

EAST WEST UNIVERSITY
 Department of Electrical and Electronic Engineering
 East West University

Address the following points briefly (Use additional page if necessary)

- What was the objective of the day's activities? (If applicable, list multiple objectives)
Today's activities was to know different parts of the combined cycle and its output.

- List the day's activities according to the order of objectives listed in 1. Mention the specifications of the equipments used/visited. Comment on how these activities fulfill your objectives. *Today's equipments are:*
 - Condenser
 - Feed pump
 - Compressor
 - Different types of relay
 - Output properties of combined cycle
 - Transformers

- Relate your practical activity with the theoretical knowledge you gained in the respective academic course.
Today's activities was directly related to our Avon station and avingear course.

Azizur Rahman
 01/01/12
 Signature of the mentor with date
 Name:
 Designation:
 Contact Phone #:

M. Atiqur
 Signature of academic supervisor with date
 Name:
 Designation:

7th Working Day: Substation Section.

EAST WEST UNIVERSITY
 Department of Electrical and Electronic Engineering
 East West University
 EEE 499
 Industrial Training
 Daily Activity Report

Separate Daily Activity Report should be completed by each intern for every day of work and should be signed by the mentor from the company and the academic advisor. Copy of all the reports should be attached to the final internship report.

| | |
|----------------------|----------------------|
| Name of the company: | APSCCL |
| Name of the student: | Md. Muzammil Hossain |
| ID: | 2007-2-RC-010 |
| Date: | 02-01-12 |
| Start time/End time | 08 AM - 04 PM |
| Location: | Substation |
| Mentor: | |

General Instructions:

- It is the intern's duty to make sure that all his/her daily activity reports are appropriately signed by both the mentor and the academic supervisor.
- The daily report should be a brief narration of the activities during the internship period in the eyes of the intern and should be completed and submitted by every intern irrespective of the number of partners s/he might have for the presentation and final report writing purpose.
- The report should not be a compilation of lectures notes taken during the internship, rather it should depict what the intern has learned on a particular day.
- In case of any confusion, interns are strongly recommended to consult their respective academic supervisors.

EAST WEST UNIVERSITY
 Department of Electrical and Electronic Engineering
 East West University

Address the following points briefly (Use additional page if necessary)

- What was the objective of the day's activities? (If applicable, list multiple objectives)
 Today's objective is to gather some basic concepts about substation, different equipments which contains substation and the protection elements of the substation.
- List the day's activities according to the order of objectives listed in 1. Mention the specifications of the equipments used/visited. Comment on how these activities fulfill your objectives. Today's activities are to focus/learn about:
 - Grid voltage: Basically grid voltage is 132kV/230kV.
 - Generating capacity of different engine and after generate at which voltage it will be stepped up.
 - Current transformer: It steps down the current.
 - Potential transformer: It steps down voltage for measurement and protection.
 - Different types of circuit breaker and their applicable voltage.
 - Different types of isolators.
 - Earth switch.
- Relate your practical activity with the theoretical knowledge you gained in the respective academic course.
 These have a great similarity with today's activity and the knowledge whatever we have gain at switchgear course.

Signature of the mentor with date: Md. Muzammil Hossain 2/1/2012
 Name: Md. Muzammil Hossain
 Designation: Student
 Contact Phone #: 01711-111111

Signature of academic supervisor with date: M. Akbar
 Name: M. Akbar
 Designation: Supervisor

8th Working Day: Substation Section.

EAST WEST UNIVERSITY
 Department of Electrical and Electronic Engineering
 East West University
 EEE 499
 Industrial Training
 Daily Activity Report

Separate Daily Activity Report should be completed by each intern for every day of work and should be signed by the mentor from the company and the academic advisor. Copy of all the reports should be attached to the final internship report.

| | |
|----------------------|----------------------|
| Name of the company: | APSCCL |
| Name of the student: | Md. Muzammil Hossain |
| ID: | 2007-2-RC-010 |
| Date: | 03-01-12 |
| Start time/End time | 08 AM - 04 PM |
| Location: | Substation |
| Mentor: | Naz Mohammad |

General Instructions:

- It is the intern's duty to make sure that all his/her daily activity reports are appropriately signed by both the mentor and the academic supervisor.
- The daily report should be a brief narration of the activities during the internship period in the eyes of the intern and should be completed and submitted by every intern irrespective of the number of partners s/he might have for the presentation and final report writing purpose.
- The report should not be a compilation of lectures notes taken during the internship, rather it should depict what the intern has learned on a particular day.
- In case of any confusion, interns are strongly recommended to consult their respective academic supervisors.

EAST WEST UNIVERSITY
 Department of Electrical and Electronic Engineering
 East West University

Address the following points briefly (Use additional page if necessary)

- What was the objective of the day's activities? (If applicable, list multiple objectives)
 Today's objective is to know about the transformer. Different parts of the transformer and its protection.
- List the day's activities according to the order of objectives listed in 1. Mention the specifications of the equipments used/visited. Comment on how these activities fulfill your objectives. Today's activity and equipments are:
 - Buccher relay: It measures the vapour oil pressure. If the increasing of vapour rate will increase very fast then we have to assume there have a decreasing of oil's dielectric strength then relay will trip.
 - Relay: There have many kind of relay known as voltage.
 - Oil temperature meter: It measures the temperature of oil.
 - Stripped bath: Collecting air and will be freed up by self.
 - Conservative tank: Reservoir the oil.
 - Bushing: Connection point of transformer.
- Relate your practical activity with the theoretical knowledge you gained in the respective academic course.
 Basically the construction of transformer we have learn on machine 2 course and here we take a practical view of those things there we also see some protection elements of transformer which was gained at switchgear course.

Signature of the mentor with date: Naz Mohammad 3/1/2012
 Name: Naz Mohammad
 Designation: Student
 Contact Phone #: 01711-111111

Signature of academic supervisor with date: M. Akbar
 Name: M. Akbar
 Designation: Supervisor

9th Working Day: Substation Section.

Department of Electrical and Electronic Engineering
East West University
 EEE 499
 Industrial Training
 Daily Activity Report

Separate Daily Activity Report should be completed by each intern for every day of work and should be signed by the mentor from the company and the academic advisor. Copy of all the reports should be attached to the final internship report.

| | |
|----------------------|--------------------|
| Name of the company: | APSC |
| Name of the student: | Md. Mezanur Rahman |
| ID: | 2007-2-80-010 |
| Date: | 04-01-12 |
| Start time/End time | 08 AM - 04 PM |
| Location: | Substation |
| Mentor: | Nur Mohammad |

General Instructions:

- It is the intern's duty to make sure that all his/her daily activity reports are appropriately signed by both the mentor and the academic supervisor.
- The daily report should be a brief narration of the activities during the internship period in the eyes of the intern and should be completed and submitted by every intern irrespective of the number of partners s/he might have for the presentation and final report writing purpose.
- The report should not be a compilation of lectures notes taken during the internship, rather it should depict what the intern has learned on a particular day.
- In case of any confusion, interns are strongly recommended to consult their respective academic supervisors.

Department of Electrical and Electronic Engineering
East West University

Address the following points briefly (Use additional page if necessary)

- What was the objective of the day's activities? (If applicable, list multiple objectives)
 Today's objective is to observe different equipments of a substation and the maintenance of a transformer.
- List the day's activities according to the order of objectives listed in 1. Mention the specifications of the equipments used/visited. Comment on how these activities fulfill your objectives. The equipments we have visited today:
 - ① Insulation
 - ② Potential transformer
 - ③ Current transformer
 - ④ Isolator
 - ⑤ Circuit breaker (SF6 minimum oil)
 - ⑥ Fusing switch
 - ⑦ 132 kV busbars
 - ⑧ 230 kV busbar
 - ⑨ Radiator
 - ⑩ Switch
 - ⑪ Conservator tank
 - ⑫ Bushing
- Relate your practical activity with the theoretical knowledge you gained in the respective academic course. Today's activities is directly related with the EEE 442.

4/1/2012

Signature of the mentor with date
 Name: Nur Mohammad
 Designation:
 Contact Phone #:

Signature of academic supervisor with date
 Name:
 Designation:

10th Working Day: Generator Section.

Department of Electrical and Electronic Engineering
East West University
 EEE 499
 Industrial Training
 Daily Activity Report

Separate Daily Activity Report should be completed by each intern for every day of work and should be signed by the mentor from the company and the academic advisor. Copy of all the reports should be attached to the final internship report.

| | |
|----------------------|----------------------|
| Name of the company: | APSC |
| Name of the student: | Md. Mezanur Rahman |
| ID: | 2007-2-80-010 |
| Date: | 06-01-12 |
| Start time/End time | 08 AM - 04 PM |
| Location: | Generator |
| Mentor: | Mohammad Kamruzzaman |

General Instructions:

- It is the intern's duty to make sure that all his/her daily activity reports are appropriately signed by both the mentor and the academic supervisor.
- The daily report should be a brief narration of the activities during the internship period in the eyes of the intern and should be completed and submitted by every intern irrespective of the number of partners s/he might have for the presentation and final report writing purpose.
- The report should not be a compilation of lectures notes taken during the internship, rather it should depict what the intern has learned on a particular day.
- In case of any confusion, interns are strongly recommended to consult their respective academic supervisors.

Department of Electrical and Electronic Engineering
East West University

Address the following points briefly (Use additional page if necessary)

- What was the objective of the day's activities? (If applicable, list multiple objectives)
 Today's objective was to know some basic concept of about generator. basically today we with discuss about the construction and classification, synchronization and excitation and the name of some protection element.
- List the day's activities according to the order of objectives listed in 1. Mention the specifications of the equipments used/visited. Comment on how these activities fulfill your objectives. Today's activities was to know:
 - ① DC generator gives a DC output by the help of commutator
 - ② AC generator gives a AC output. basically the output can be in single phase or three phase output. also known as alternator.
 - ③ Salient pole generator?
 - ④ Non salient pole generator?
 - ⑤ Different types of maintenance work: carbon brush checking, air filter cleaning, identification, checking of shaft voltage measurement.
- Relate your practical activity with the theoretical knowledge you gained in the respective academic course.
 Basically today's activity was related to machine course.

06/01/12

Signature of the mentor with date
 Name: Mohammad Kamruzzaman
 Designation: Asst. Engr. (Generator)
 Contact Phone #: Adjacent Power Station Co. Ltd. Ashgaria, Dhaka-1202

Signature of academic supervisor with date
 Name:
 Designation:

11th Working Day: Generator Section.

Department of Electrical and Electronic Engineering
East West University
EEE 499
Industrial Training
Daily Activity Report

Separate Daily Activity Report should be completed by each intern for every day of work and should be signed by the mentor from the company and the academic advisor. Copy of all the reports should be attached to the final internship report.

| | |
|----------------------|----------------------------------------------------|
| Name of the company: | Ashuganj Power Station Company Ltd. |
| Name of the student: | Syed Rumman Hossain |
| ID: | 2007-2-80-021 |
| Date: | 3/1/12 |
| Start time/End time: | 8am-4pm (lunch 1pm-2pm) |
| Location: | Generator section |
| Mentor: | Mohammad Kamruzzaman (Senior Engineer) (generator) |

General Instructions:

- It is the intern's duty to make sure that all his/her daily activity reports are appropriately signed by both the mentor and the academic supervisor.
- The daily report should be a brief narration of the activities during the internship period in the eyes of the intern and should be completed and submitted by every intern irrespective of the number of partners who might have for the presentation and final report writing purpose.
- The report should not be a compilation of lectures notes taken during the internship, rather it should depict what the intern has learned on a particular day.
- In case of any confusion, interns are strongly recommended to consult their respective academic supervisors.

Department of Electrical and Electronic Engineering
East West University

Address the following points briefly (Use additional page if necessary)

- What was the objective of the day's activities? (If applicable, list multiple objectives)
The objective of that day was to know about the different type of protection system of the generators.
- List the day's activities according to the order of objectives listed in 1. Mention the specifications of the equipments used/visited. Comment on how these activities fulfill your objectives.
In the power plant the protection of the generator is very important, so we should know all possible protection of the generator. The most important protection are:
(1) Over current protection; (2) Over current with under voltage protection; (3) over voltage protection; (4) Under frequency protection; (5) Negative phase sequence; (6) Reverse power protection; (7) Minimum impedance protection; (8) Loss of Excitation; (9) Winding differential protection; (10) Stator earth fault protection; (11) Back up earth fault protection; (12) Rotor earth fault; (13) Distance protection; (14) Unit transformer
- Relate your practical activity with the theoretical knowledge you gained in the respective academic course.
We learned about the protection system in our switchgear course but on the course we learned very few protection system. And in our internship the instructor gave us the knowledge of all kind of protection system for generator which are use in the APSC.

Signature of the mentor with date
Name: *Mohammad Kamruzzaman*
Designation: Senior Eng. (Generator)
Contact Phone #: Ashuganj Power Station Co. Ltd. Ashuganj, G.P.O. - 1459

Signature of academic supervisor with date
Name: FMA
Designation: LECTURER

12th Working Day: Generator Section.

Department of Electrical and Electronic Engineering
East West University
EEE 499
Industrial Training
Daily Activity Report

Separate Daily Activity Report should be completed by each intern for every day of work and should be signed by the mentor from the company and the academic advisor. Copy of all the reports should be attached to the final internship report.

| | |
|----------------------|----------------------------------------------------|
| Name of the company: | Ashuganj power station company Ltd. |
| Name of the student: | Syed Rumman Hossain |
| ID: | 2007-2-80-021 |
| Date: | 09/01/12 |
| Start time/End time: | 8am-4pm (lunch 1:00pm-2:00pm) |
| Location: | Generator section |
| Mentor: | Mohammad Kamruzzaman (Senior Engineer) (generator) |

General Instructions:

- It is the intern's duty to make sure that all his/her daily activity reports are appropriately signed by both the mentor and the academic supervisor.
- The daily report should be a brief narration of the activities during the internship period in the eyes of the intern and should be completed and submitted by every intern irrespective of the number of partners who might have for the presentation and final report writing purpose.
- The report should not be a compilation of lectures notes taken during the internship, rather it should depict what the intern has learned on a particular day.
- In case of any confusion, interns are strongly recommended to consult their respective academic supervisors.

Department of Electrical and Electronic Engineering
East West University

Address the following points briefly (Use additional page if necessary)

- What was the objective of the day's activities? (If applicable, list multiple objectives)
The objective of that day was to know the construction of the rotor, voltage induce and synchronization system.
- List the day's activities according to the order of objectives listed in 1. Mention the specifications of the equipments used/visited. Comment on how these activities fulfill your objectives.
Here the generator which are using in the system generally two pole construction. In the rotor there have slot system and every slot consist more conductor for get the more flux. This flux can be produce by the supply of the DC voltage. This flux produce AC voltage. The direction of the flux work like the right hand rule.
Synchronization is the important part of the generator. For the synchronization generator should maintain three important condition and those are, Voltage level will be same, Frequency will be same (P.T.O)
- Relate your practical activity with the theoretical knowledge you gained in the respective academic course.
On that we saw the generating units and the construction of the turbine shaft with bearing which was repairing, We also saw the control unit which control the synchronization and other important thing.

Signature of the mentor with date
Name: *Mohammad Kamruzzaman*
Designation: Senior Eng. (Generator)
Contact Phone #: Ashuganj Power Station Co. Ltd. Ashuganj, G.P.O. - 1459

Signature of academic supervisor with date
Name: FMA
Designation: LECTURER

13th Working Day: Operation Section.

Department of Electrical and Electronic Engineering
East West University
EEE 499
Industrial Training
Daily Activity Report

Separate Daily Activity Report should be completed by each intern for every day of work and should be signed by the mentor from the company and the academic advisor. Copy of all the reports should be attached to the final internship report.

| | |
|----------------------|---------------------------------------------|
| Name of the company: | Ashuganj power station company Ltd |
| Name of the student: | Syed Rumman Hossain |
| ID: | 2007-2-80-021 |
| Date: | 5/1/12 |
| Start time/End time | 8:00 am - 4:00 pm (lunch 1:00 pm - 2:00 pm) |
| Location: | operation v section |
| Mentor: | Engr Md. Anwar Hossain |

General Instructions:

- It is the intern's duty to make sure that all his/her daily activity reports are appropriately signed by both the mentor and the academic supervisor.
- The daily report should be a brief narration of the activities during the internship period in the eyes of the intern and should be completed and submitted by every intern irrespective of the number of partners s/he might have for the presentation and final report writing purpose.
- The report should not be a compilation of lectures notes taken during the internship, rather it should depict what the intern has learned on a particular day.
- In case of any confusion, interns are strongly recommended to consult their respective academic supervisors.

Department of Electrical and Electronic Engineering
East West University

Address the following points briefly (Use additional page if necessary)

- What was the objective of the day's activities? (If applicable, list multiple objectives)
The objective of that day was to learn about the water and steam cycle of the unit 4 & 5
- List the day's activities according to the order of objectives listed in 1. Mention the specifications of the equipments used/visited. Comment on how these activities fulfill your objectives.
Condenser
Condenser pump
Low pressure heater 1 & 2
High pressure heater 1 & 2
Boiler feed pump
FD fan
gas pressure control system
- Relate your practical activity with the theoretical knowledge you gained in the respective academic course.
In our theoretical part we learn about the steam turbine operation with a brief but here we learned something more explanation

Signature of the mentor with date: Md. Anwar Hossain
Name: _____
Designation: _____
Contact Phone #: _____

Signature of academic supervisor with date: Md. Anwar Hossain
Name: FMA
Designation: LECTURER

14th Working Day: Operation Section.

Department of Electrical and Electronic Engineering
East West University
EEE 499
Industrial Training
Daily Activity Report

Separate Daily Activity Report should be completed by each intern for every day of work and should be signed by the mentor from the company and the academic advisor. Copy of all the reports should be attached to the final internship report.

| | |
|----------------------|---------------------------------------------|
| Name of the company: | Ashuganj power station company Ltd |
| Name of the student: | Syed Rumman Hossain |
| ID: | 2007-2-80-021 |
| Date: | 5/1/12 |
| Start time/End time | 8:00 am - 4:00 pm (lunch 1:00 pm - 2:00 pm) |
| Location: | operation section |
| Mentor: | Engr Md. Anwar Hossain |

General Instructions:

- It is the intern's duty to make sure that all his/her daily activity reports are appropriately signed by both the mentor and the academic supervisor.
- The daily report should be a brief narration of the activities during the internship period in the eyes of the intern and should be completed and submitted by every intern irrespective of the number of partners s/he might have for the presentation and final report writing purpose.
- The report should not be a compilation of lectures notes taken during the internship, rather it should depict what the intern has learned on a particular day.
- In case of any confusion, interns are strongly recommended to consult their respective academic supervisors.

Department of Electrical and Electronic Engineering
East West University



Address the following points briefly (Use additional page if necessary)

- What was the objective of the day's activities? (If applicable, list multiple objectives)
The objective of that day was to see the the reheater and by pass system and super heater.
- List the day's activities according to the order of objectives listed in 1. Mention the specifications of the equipments used/visited. Comment on how these activities fulfill your objectives.
super heater 1, 2, & 3
*super heater 1 has 2 section
super heater three has the temperature about 486 cel to 485 cel.
super heater two has the temperature about 418 cel to 413 cel.
super heater one has the temperature about 303 cel to 301 cel. All of super heaters take the heat from the flue gas.
- Relate your practical activity with the theoretical knowledge you gained in the respective academic course.
In our theory part we learn about the super heater and here we know about the working principle of the super heater.

Signature of the mentor with date: Md. Anwar Hossain
Name: _____
Designation: _____
Contact Phone #: _____

Signature of academic supervisor with date: Md. Anwar Hossain
Name: FMA
Designation: LECTURER

15th Working Day: Operation Section.

| | | | |
|--------------------------------------------------------------------------------------------------------------------------------------------------------------------------------------------------------------------------|--|---------------------------------------------------------------------------------------------------------------------------------------------------------------|--|
|  Department of Electrical and Electronic Engineering East West University EEE 499 Industrial Training Daily Activity Report | |  Department of Electrical and Electronic Engineering East West University | |
| Address the following points briefly (Use additional page if necessary) | | | |
| 1. What was the objective of the day's activities? (If applicable, list multiple objectives) | | | |
| The objective of that day was to see the feed water tank and boiler and there system and there pump. Here we also see the burner and the combustion system. Operation of turbine. | | | |
| 2. List the day's activities according to the order of objectives listed in 1. Mention the specifications of the equipments used/visited. Comment on how these activities fulfill your objectives. | | | |
| 1) bush burner feed water tank Decarator water flow control valve gas Thermostide condenser pump safety valve Flash vessel → | | Down comer header Raiser make up water tank Reserve tank stack | |
| 3. Relate your practical activity with the theoretical knowledge you gained in the respective academic course. | | | |
| On the theoretical knowledge we d learn had about the boiler and combustion chamber. Here we visually see the those system and there construction. | | | |
| Signature of the mentor with date Name: Designation: Contact Phone #: | | Signature of academic supervisor with date Name: <u>FMA</u> Designation: <u>LECTURER</u> | |

Separate Daily Activity Report should be completed by each intern for every day of work and should be signed by the mentor from the company and the academic advisor. Copy of all the reports should be attached to the final internship report.

| | |
|----------------------|---------------------------------------------|
| Name of the company: | Ashugari power station company Ltd |
| Name of the student: | Syed Ruman Hossain |
| ID: | 2007-2-20-021 |
| Date: | 8/1/12 |
| Start time/End time | 8:00 am - 9:00 pm (lunch 1:00 pm - 2:00 pm) |
| Location: | operation section |
| Mentor: | Engr Md. Anwar Hossain |

- General Instructions:
- It is the intern's duty to make sure that all his/her daily activity reports are appropriately signed by both the mentor and the academic supervisor.
 - The daily report should be a brief narration of the activities during the internship period in the eyes of the intern and should be completed and submitted by every intern irrespective of the number of partners s/he might have for the presentation and final report writing purpose.
 - The report should not be a compilation of lectures notes taken during the internship, rather it should depict what the intern has learned on a particular day.
 - In case of any confusion, interns are strongly recommended to consult their respective academic supervisors.