



Title of the Research Paper

Design a Dispersion Compensating Hexagonal Photonic Crystal Fiber

Submitted by

Farzana Aktar Monni

Student ID: 2010-2-55-011

Annesha Haque Bhuiya

Student ID: 2010-3-55-020

Supervisor

Dr. Feroza Begum

Assistant Professor

Department of Electronics and Communication Engineering

East West University

Declaration

We hereby declare that we have completed research paper on the topic entitled “Design a dispersion compensating hexagonal photonic crystal fiber” as well as prepared research report which is the partial fulfillment of the requirement for the degree of B.Sc. in Electronics and Telecommunication Engineering under the course “Research/Internship (ETE 498)”.

We further assert that the work presented in this report is our own and has not been submitted elsewhere for the requirement of any degree or for any other purpose except for publication.



Farzana Aktar Monni

ID: 2010-2-55-011



Animesha Haque Bhuiya

ID: 2010-3-55-020

**Department of Electronics and Communication Engineering
East West University**

Acceptance

This research report presented to the Department of Electronics and Communication Engineering (ECE), East West University is submitted in partial fulfillment of the requirement for degree of B.Sc. in Electronics and Telecommunication Engineering, under complete supervision of the undersigned.

We wish to say thank
Chairman and Committee

Signature 07/09/2014

Dr. Feroza Begum
Assistant Professor
Department of ECE
East West University

Acknowledgment

At first, we wish to convey our cordial thanks to Almighty Allah. We would like to thank our parents who has supported us all the way through to complete my education. We would also like to thank East West University for providing us with the journal papers, books and research paper which helped us for completion of our research paper.

We wish to say special thanks to Dr. Feroza Begum (Assistant Professor, Department of Electronic and Communication Engineering) for guiding us with lots of time and effort, and provided us with suggestion during the preparation of this research paper. We even appreciate the help we received from other faculties of ECE Department.

We are very grateful especially towards senior brother and sisters who also helped us in many ways to complete our research paper. Otherwise it was difficult to us for completion our research paper.

Abstract

In this paper we have designed a model of hexagonal photonic crystal fiber (HPCF) where we changed the parameters- diameter of air hole d , pitch Λ to observe the effect on properties of photonic crystal fiber (PCF). Using Comsol multiphysic 4.3b we have designed a five ringed HPCF with the finite element method and with boundary condition perfectly matched absorbing layers (PML) to investigate the guiding properties. It is considered to be the most efficient boundary condition for the PCF simulation. At first we kept the pitch constant and varied the diameter of the air hole and saw the effect on effective mode index n_{eff} , effective area A_{eff} , confinement loss L_c and chromatic dispersion D . Similarly, we changed the value of pitch keeping the diameter of the air hole constant. For dispersion compensating fiber in communication system we required negative dispersion at $1.55 \mu\text{m}$ wavelength, this is because at $1.55 \mu\text{m}$ wavelength we have minimum attenuation. Through our research we observed that for value of pitch $\Lambda = 0.8 \mu\text{m}$ and air hole diameter $d = 0.38 \mu\text{m}$, we get negative chromatic dispersion value approximately around -1205 ps/nm/km for $1.55 \mu\text{m}$ wavelength. This proposed HPCF is used for dispersion compensating fiber in communication system.

Contents

Chapter 1 Introduction

1.1 Optical fiber	1
1.2 Ray theory transmission	4
1.3 Optical fiber communication system	7
1.4 Advantages	8
1.5 Application	9

Chapter 2 Photonic crystal fiber

2.1 Photonic crystal fiber	10
2.2 Photonic crystal	12
2.3 Maxwell Equation	14
2.4 Properties of photonic crystal fiber	15

Chapter 3 Dispersion compensating photonic crystal fiber

3.1 Introduction	21
3.2 Results and discussion	23
3.3 Conclusion	37

Chapter 4 Conclusion.....

References.....

Chapter 1

Introduction

1.1 Optical fiber

1.2 Ray theory transmission

1.3 Optical fiber communication system

1.4 Advantages

1.5 Applications

1.1 Optical fiber

Optical fiber is a transparent fiber made of pure glass (silica) it is as thin as a human hair. It is **used to carry digital signals** in form of light. The beam is transported from one end to another **by total internal reflection**. It is flexible, has high bandwidth, and no electrical interference. **The core** of the fiber is surrounded by a special protection coating known as cladding, which **helps the light to propagate** through the core of the fiber as well as it protects the core [1].

There are two types of optical fibers:

A. Conventional optical fiber

I. Multimode

- Step index
- Graded index

II. Single mode

B. Photonic crystal fiber

- Index guiding photonic crystal fiber
- Photonic crystal band gap fiber

3.1.1 Multimode fiber:

It is a fiber that has many propagation paths. The core diameter of this fiber is larger than the wavelength of the transmitted light. It is used for short distance communications because it has low light intensity than that of the single mode fiber [1].

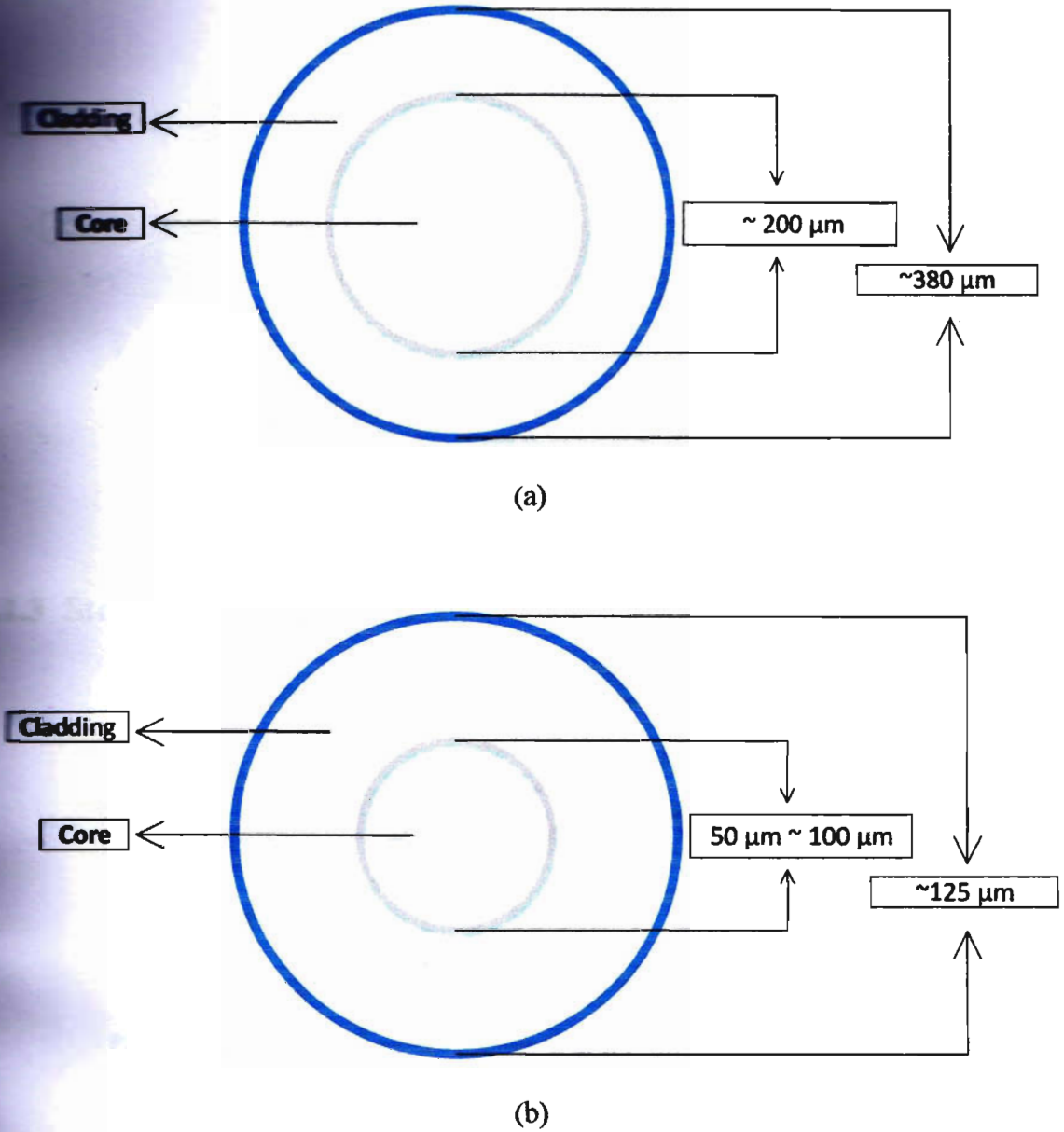

Fig.1: (a) Step index multimode fiber, and(b) Graded index multimode fiber.

1.1.2 Single mode fiber:

It is a fiber that supports only one propagation path. It has smaller core diameter than the multimode fiber and is used for most long distance communications as it has high intensity light compared to multimode fiber [1].

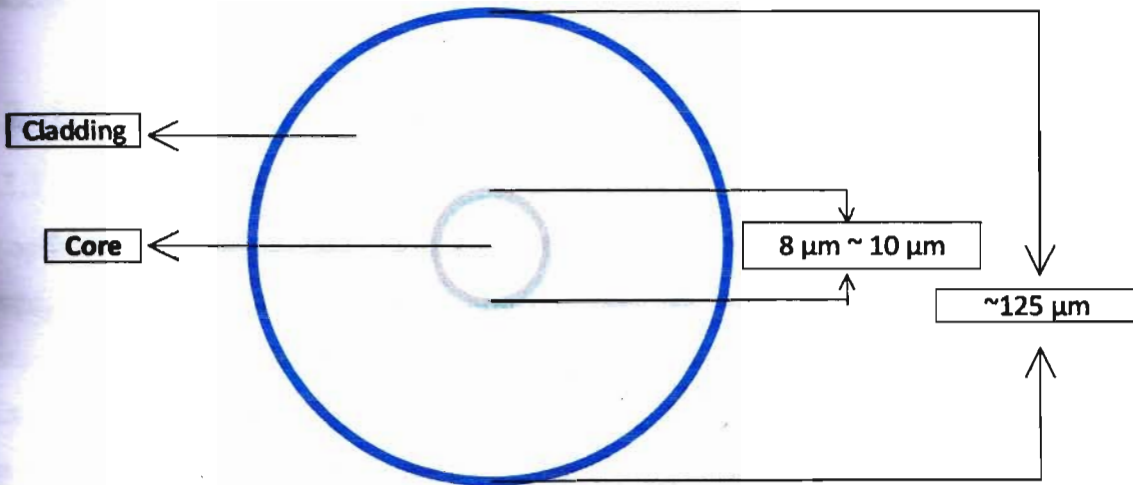

Fig.2: Structure of single mode fiber.

1.1.3 Structure of optical fiber:

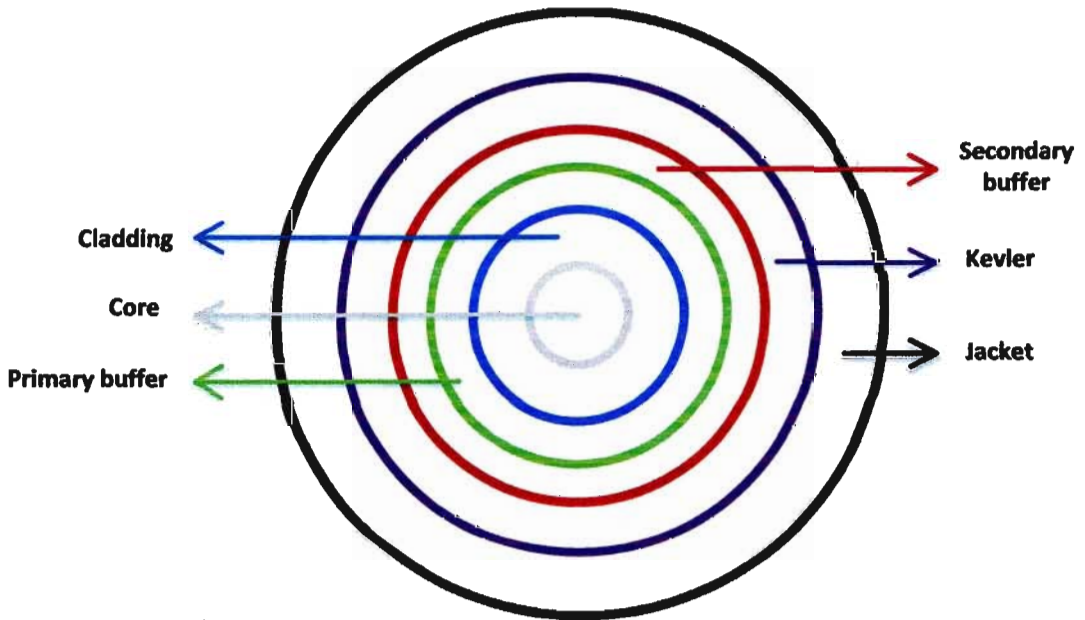

Fig.3: Structure of optical fiber.

Core: Light always passes through the core.

Cladding: It protects the core and helps light to propagate through the core of the fiber.

Primary buffer: It protects the fiber and is made up of plastic.

Secondary buffer: It is used for color coding identity.

Kevlar: It protects the whole fiber as it is five times stronger than steel.

Jacket: It is used to protect the fiber from weather.

1.2 Ray theory transmission

1.2.1 Total internal reflection:

In optical fiber light propagates within the fiber by total internal reflection, to measure this propagation we have to consider the refractive index of the fiber. It is said that light travels faster in less dense medium than that of denser medium, refractive index helps to measure this effect. Let the refractive index of the core be n_1 , and refractive index of the cladding n_2 , the angle of incident θ_1 and the angle of refraction θ_2 from Snell's law of refraction we can write,

$$n_1 \sin \theta_1 = n_2 \sin \theta_2 \quad (1)$$

Or,

$$\frac{\sin \theta_1}{\sin \theta_2} = \frac{n_2}{n_1} \quad (2)$$

It may also be observed that a small amount of light is reflected back into the originating dielectric medium. Here the light should be stay in core so the condition is that the incident light angle θ_1 is greater than critical angle θ_c and the core refractive index is greater than cladding refractive index [1].

$$\text{Critical angle, } \theta_c = \sin^{-1} \frac{n_2}{n_1} \quad (3)$$

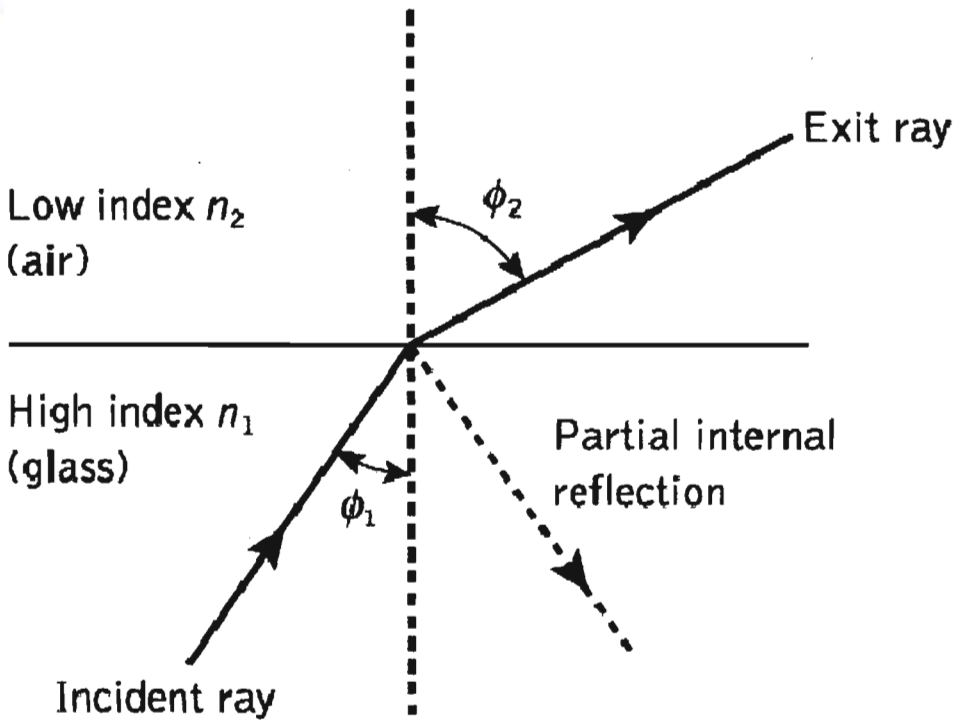

(a)

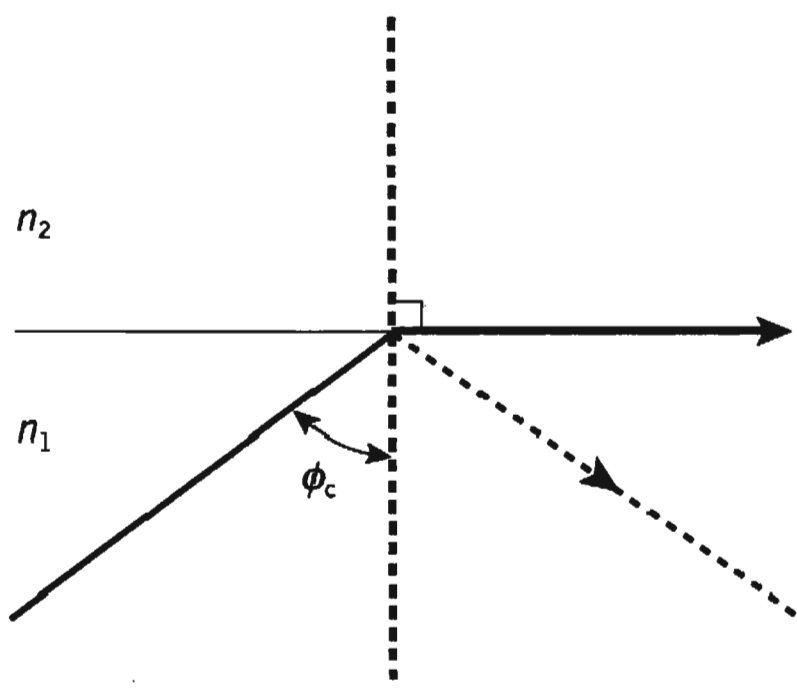

(b)

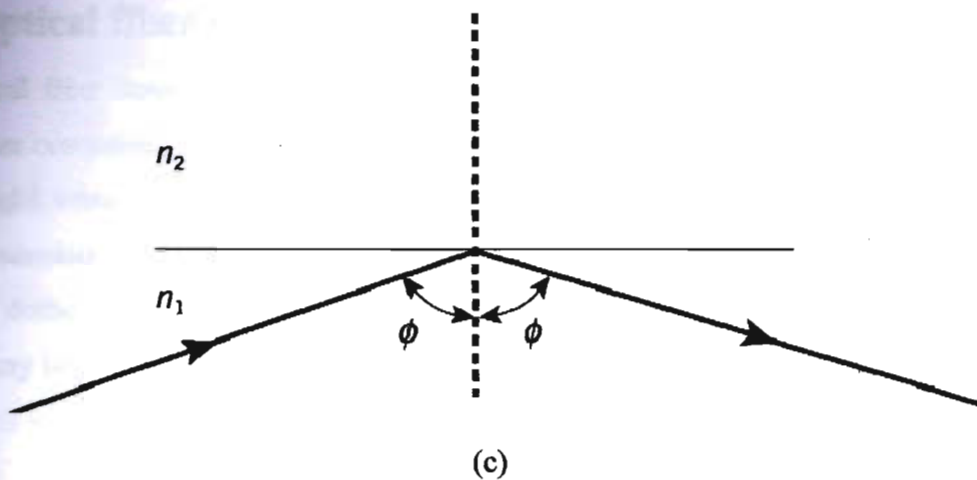

Fig. 4: Light rays incident on a high to low refractive index interface: (a) refraction, (b) the limiting case of refraction showing the critical ray at an angle θ_c and (c) total internal reflection where $\theta_1 > \theta_c$.

1.2.2 Acceptance angle:

The acceptance angle of an optical system characterizes the range of angles over which the system can accept or emit light.

$$\text{Acceptance angle, } \theta_a = \sin^{-1} \text{NA} \tag{4}$$

Where, NA = numerical aperture which is a dimensional number that determines the capacity of the fiber for light to pass through [1].

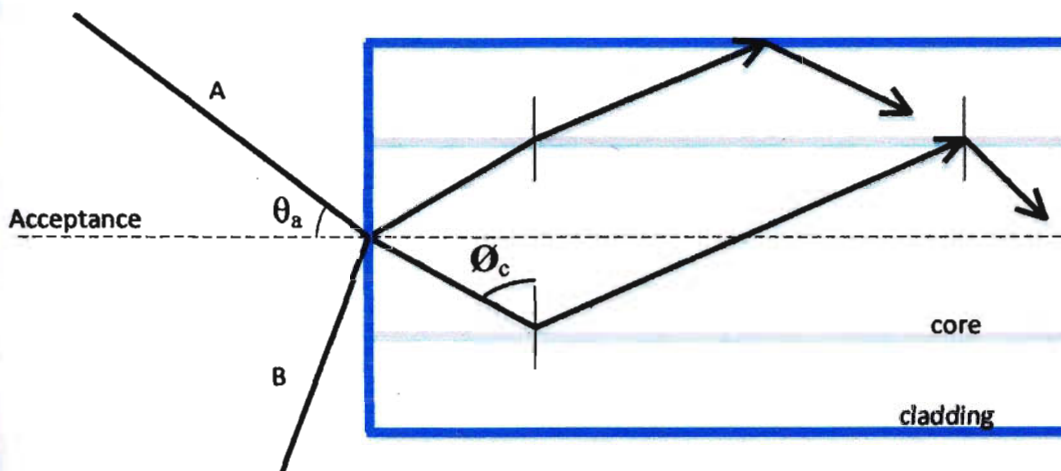

Fig.5: Acceptance angle θ_a when light inserts in optical fiber.

1.3 Optical fiber communication system:

For optical fiber communication the information source provides an electrical signal to a transmitter comprising an electrical stage which drives an optical source to give modulation of the light wave carrier. The transmission medium consists of an optical cable and the receiver consists of optical detector. That detector drives a further electrical stage and hence provides demodulation of the optical carrier. Using analog or digital information the optical carrier may be modulated. Analog modulation has continuous variation of light emitted from the optical source and digital modulation has discrete changes in the light intensity [1].

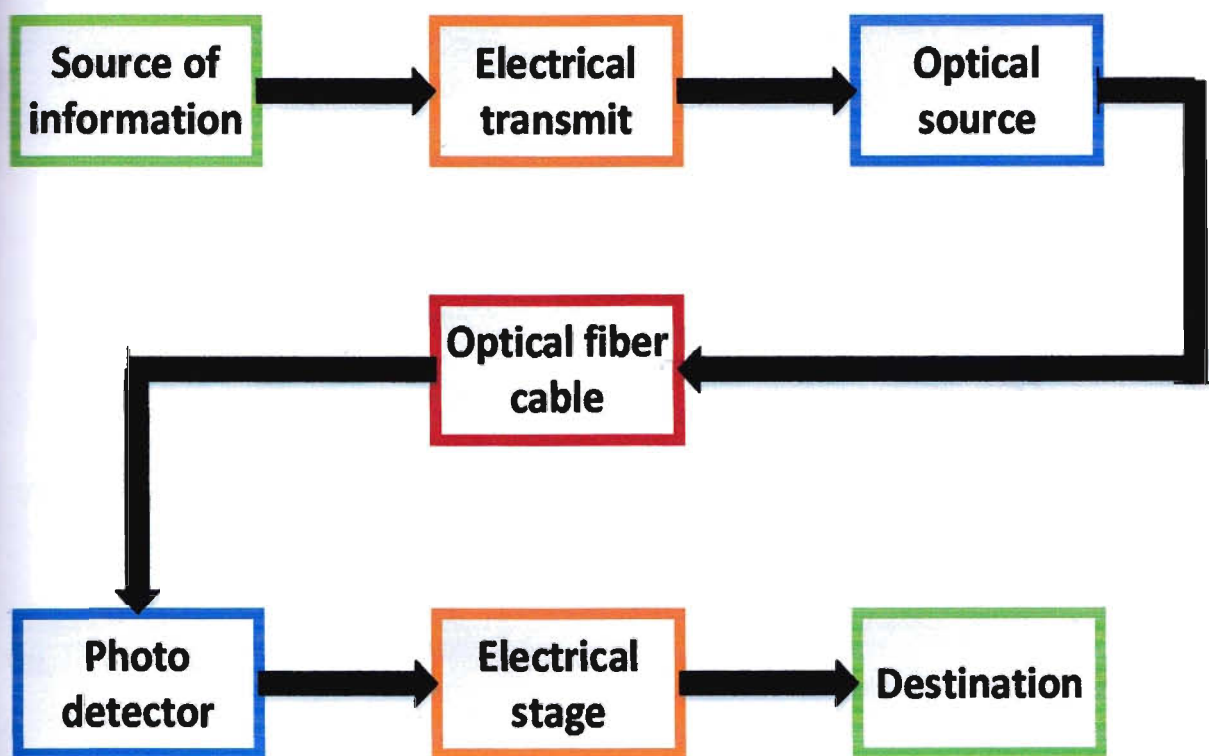

Fig. 6: Optical communication system

1.4 Advantages

I. Enormous potential bandwidth

The optical carrier frequency range is 10^{13} to 10^{16} Hz which has greater potential transmission than metallic cable systems.

II. Small size and weight

Since the diameter of the optical fiber is very small even with the coatings is smaller than copper wires and hence is lighter in weight.

III. Electrical isolation

Since optical fiber is made of glass or plastic it is electrical insulator in nature hence unlike metal wires it does not create any interference with the earth loop nor creates any sparks hazards.

IV. Immunity to interference and crosstalk

Optical fiber forms dielectric waveguide so it is immune to electromagnetic interference or radio interference so it can be used in electrical noisy environment. Since there is no optical interference so crosstalk is not possible.

V. Signal security

There is a security in optical fiber since the light does not radiate significantly from the fiber

VI. Low transmission loss

It has a very low attenuation loss as low as 0.2 dB km^{-1} resulting in reduction of both system cost and complexity.

VII. Flexible

Optical fibers are very flexible it has small radius and can be twisted without damage. It is very strong and is durable.

VIII. System reliable and ease of maintenance

Since there is low loss in the fiber less number of amplifier is required. As the number of amplifier or any electrical components reduces the maintenance get easier and the system becomes reliable.

IX. Potential low cost

It is made of sand or glass which is available resources.

15 Applications:

Now a day there are many application of optical fiber and new features also continue to add [1].

- I. Telecommunication
- II. Computer networking
- III. Fiber optic sensors
- IV. Illuminations
- V. Medical endoscope, baroscopic
- VI. Industrial endoscope
- VII. To inspect plumbing and sewer lines.

Photonic Crystal Fiber

2.1 Photonic crystal fiber

2.2 Photonic crystal

2.3 Maxwell Equation

2.4 Properties of photonic crystal fiber

2.1 Photonic crystal fiber

Photonic crystal fiber (PCF) is a fiber that was first demonstrated in 1996 and has been popular since then. It is periodic nanostructures that affect the motion of photons like as that ionic lattice affect electrons in solids. It occurs in nature in the form of structure coloration. It is made from the concept of photonic crystal and is very flexible. The core of this particular fiber is made of single material such as silica and can either be solid or empty. The core is surrounded by air holes which runs through the fiber hence it is known as 'holey' or 'micro-structured' fiber. Due to this structure the core acts as a cavity where the light is confined and transmitted [1].

The fiber is divided into two different fibers:

- Index guiding photonic crystal fiber
- Photonic band gap fiber

2.1.1 Index guiding photonic crystal fiber:

In index guiding PCF light is guided by the total internal reflection between the solid core and multiple air holes cladding.

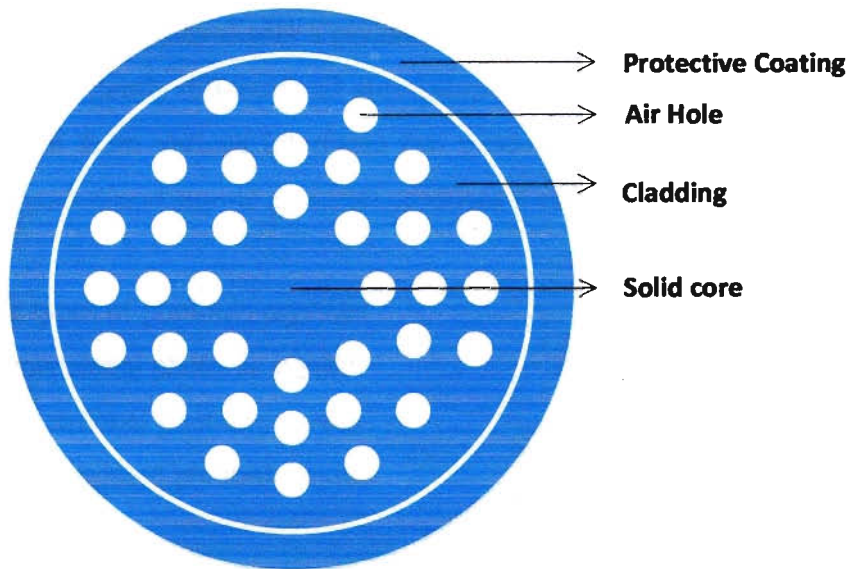

Fig. 1: Structure of index guiding photonic crystal fiber.

2.1.2 Photonic band gap fiber:

Photonic band gaps are that the periodicity of the crystal induced a gap in its band structure. No electromagnetic modes are allowed to have frequency in the gap. Its effect is exhibited in photonic crystal band gap fiber where the wavelength guides light in a low index core region.

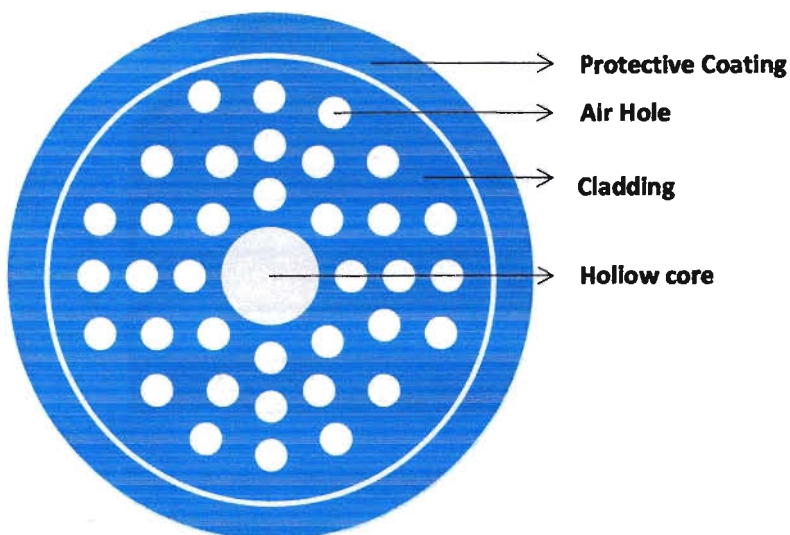

Fig. 2: Structure of photonic band gap fiber.

2.2 Photonic crystal

Photonic crystals are periodically arrangement of dielectric media that affect the propagation of electromagnetic wave. This affect is similar to the periodic potential in a silicon (semiconductor) crystal which affects the electron motion. Here periodic potential is replaced by periodic function (or equivalently a periodic index of refraction). If the dielectric constants of material are sufficiently different and absorption of light is minimal then the refraction and reflection of light from various interfaces can produce many of the same phenomena for photons (light modes) and atomic potential produces for electrons [2].

There are three types of photonic crystals:

- I. One dimensional photonic crystal
- II. Two dimensional photonic crystal
- III. Three dimensional photonic crystal

2.2.1 One dimension photonic crystal:

One dimension photonic crystal is alternating layers of different dielectric constant (multilayer film) which are deposited to form a band gap in a single direction. In 1887 published Lord Rayleigh first analyses of multilayer films properties. This type of photonic crystal can act as a mirror (a Bragg mirror). These concepts are commonly used in dielectric mirrors optical fiber and optical switch. One dimensional photonic crystal can be either isotopic or anisotropic [2].

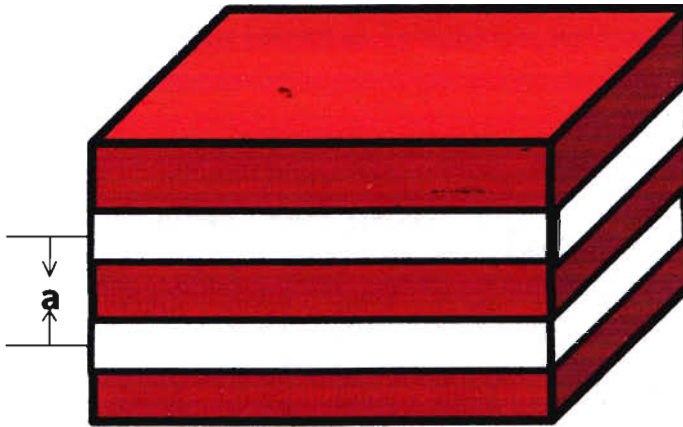

Fig. 3: The multilayer film, a one-dimensional photonic crystal. The system consists of alternating layers of materials (white and red) with different dielectric constant with a spatial period a .

2.2.2 Two dimensional photonic crystal:

In 1996 Thomas Krauss first established the two-dimension photonic crystal at optical wavelengths. This opened us the way for photonic crystals to be fabricated in semiconductor materials. Today this techniques use photonic crystal slabs. It consists of a square lattice of dielectric constant. A two-dimensional photonic crystal is periodic along two its axes(x, y) [2].

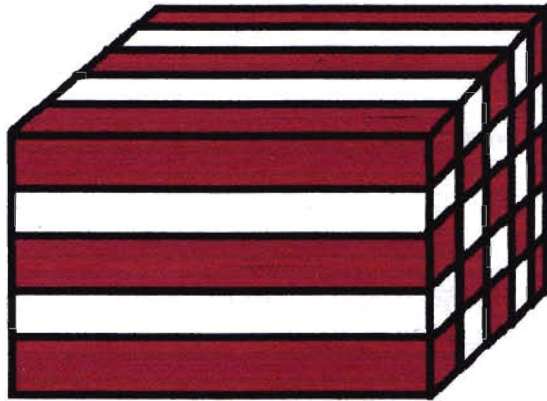

Fig. 4:Two-dimensional photonic crystal.

2.2.3 Three dimensional photonic crystal:

The three dimensional photonic crystal is a periodic dielectric structure along three different axes. There are many possible geometries for a three dimensional photonic crystal. But we emphasize on those geometries that promotes the existence of photonic band gaps [2]. There are several examples of three dimensional crystals with a complete band gaps: a diamond lattice of air holes, a drilled dielectric known as Yablonovite, the wood pile structure etc.

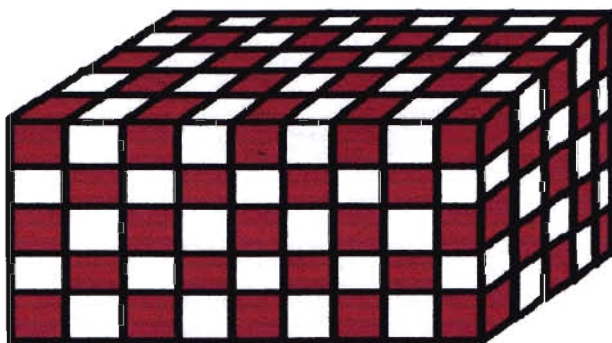

Fig. 5:Three-dimensional photonic crystal.

2.3 Maxwell Equation:

To study the propagation of light in a photonic crystal we use the Maxwell equation. After specializing case of a mix dielectric medium we use the Maxwell equation as a linear Hermitianeigen value problem. This problem brings the electromagnetic problem hat close with the Schrodinger equation which allows us to well-established the result from quantum-mechanics where the electromagnetic case differs from the quantum-mechanical case. Photonic crystals do not generally have a fundamental scale, in either the spatial coordinate or the potential strength [2].

So including the propagation of light in a photonic crystal, the Maxwell equation in SI unit is given below:

$$\text{Faraday's Law: } \nabla \times E = -\partial B / \partial t \quad (5)$$

$$\text{Ampere's Law: } \nabla \times H = J + \partial D / \partial t \quad (6)$$

$$\text{Gauss's Law: } \nabla \cdot D = \rho \quad (7)$$

$$\nabla \cdot B = 0 \quad (8)$$

Where E is the electric filed, H is the magnetic field, B is the magnetic flux density, D is the electric displacement, J is the electric current density and ρ is the electric charge density.

So the Maxwell curl equation,

$$\nabla \times E + \partial B / \partial t = 0 \quad (9)$$

$$\nabla \times H - \partial D / \partial t = J \quad (10)$$

2.4 Properties of photonic crystal fiber:

Focus on the properties of photonic crystal:

- I. Chromatic dispersion, $D(\lambda)$
- II. Confinement loss, L_c
- III. Effective area, A_{eff}

2.4.1 Chromatic dispersion:

Chromatic dispersion contributes as the major technique for controlling the loss in the index-guiding photonic crystal fiber (PCF). Control of chromatic dispersion in PCF is a very important problem for our practical application to optical communication system. Chromatic dispersion can be controlled or modified by varying few parameters such as the air hole diameter d , the hole to hole spacing also known as the pitch Λ and the shape of the air holes. Moreover, the real part of effective mode index has an effect of chromatic dispersion.

Effective mode index for a given wavelength is obtained by solving Eigen value problem from Maxwell equation. Effective mode index is a complex values and it has a real and imaginary part [3, 5]. So the effective mode index, n_{eff} is obtained as

$$n_{\text{eff}} = \frac{\beta}{k_0} \quad (11)$$

Where β is the propagation constant and k_0 is the free space wave number.

Sellmeier equation is an empirical relationship between refractive index and wavelength for particular transparent and non-transparent medium. This equation is used to determine the dispersion of light. So the equation is define as

$$n_{\text{eff}}^2 = 1 + \frac{B_1 \lambda^2}{\lambda^2 - C_1} + \frac{B_2 \lambda^2}{\lambda^2 - C_2} + \frac{B_3 \lambda^2}{\lambda^2 - C_3} \quad (12)$$

Where n_{eff} is the refractive index, λ is the wavelength, and $B_{1,2,3}$ and $C_{1,2,3}$ are the coefficients of Sellmeier equation.

Table 1: Coefficients and values of Sellmeier equation.

Coefficient	Value
B ₁	0.6961663
B ₂	0.4079426
B ₃	0.8974794
C ₁	0.0684043e-6
C ₂	0.1162414e-6
C ₃	9.896161e-6

Dispersion is a general term that transmitted optical signal causes boarding of the transmitted light pluses as they travel along the fiber. Total dispersion or chromatic dispersion D consists of two components one is material dispersion D_m and another is waveguide dispersion D_w .

$$D = D_m + D_w \quad (13)$$

To control the chromatic dispersion in PCFs, dispersion compensation and linear or nonlinear optics the waveguide dispersion D_m of the PCF is obtained from the n_{eff} value against the wavelength using,

$$D = -\frac{\lambda}{c} \frac{d^2 \text{Re}(n_{eff})}{d\lambda^2} \quad (14)$$

Chromatic dispersion management design is divided in four categories:

- I. Non-zero dispersion shifted fiber(NZDSF)
- II. Dispersion flattened fiber(DFP)
- III. Dispersion compensation fiber(DCF)
- IV. Negative dispersion fiber(NDF)

2.4.1.1 Non-zero dispersion shifted fiber (NZDSF):

It is a single mode fiber to overcome the dispersion shifted fiber problem. NZDSF is two types NZD+ and NZD-. Because of the NZDSF the normal communication window is four

waves mixing and non-linear effect is minimize. The minimum non-zero dispersion is around 1300 to 1550 nm region. It's providing low dispersion across the minimum loss at 1550nm. This system efficiency is increased due to longer repeater spacing that is most important consideration in long distance optical communication system [4].

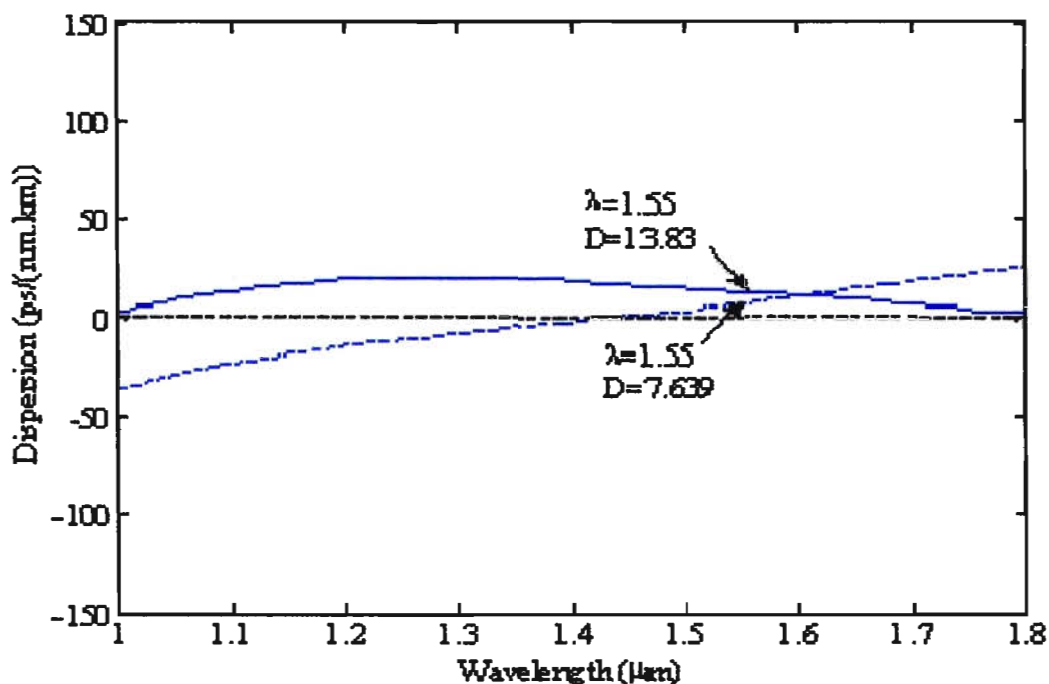

Fig. 6: Chromatic dispersion of NZ-DSF.

2.4.1.2 Dispersion flattened fiber (DFF):

Dispersion flattening occurs by partial cancellation of waveguide dispersion by material dispersion in the wavelength range of operation. The information capacity and wavelength division multiplexing (WDM) schemes of the optical fiber system can be increase by using the DFF. Dispersion flattened has the possibility of low dispersion over the extended range of wavelengths [4].

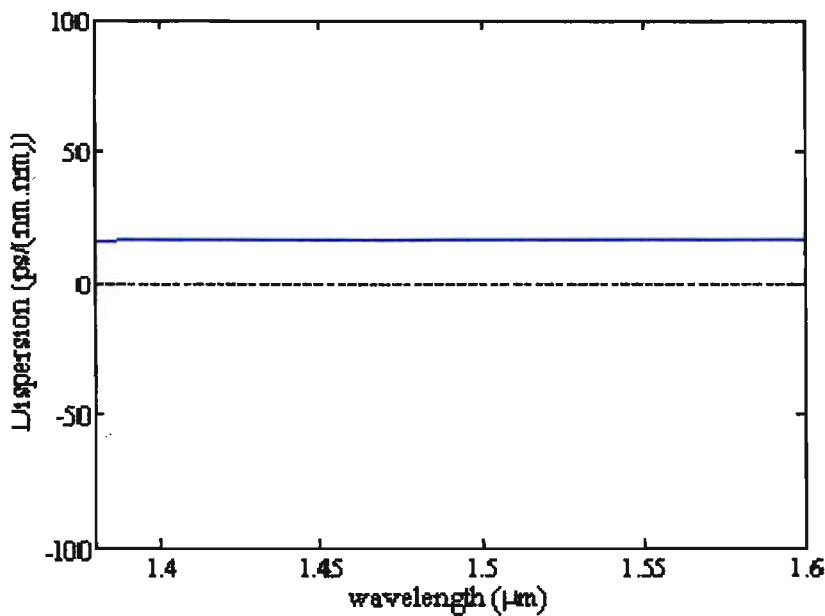

Fig. 7: Chromatic dispersion of DFF.

2.4.1.3 Dispersion compensation fiber (DCF):

To increase the capacity of the long haul optical communication system and control the detrimental nonlinear effects such as self-phase modulation (SPM), cross phase modulation (XPM) and four wave mixing (FWM) in WDM system of single mode by use the dispersion compensating PCF. Dispersion compensating fibers have a larger negative dispersion to compensate the main fiber dispersion [4].

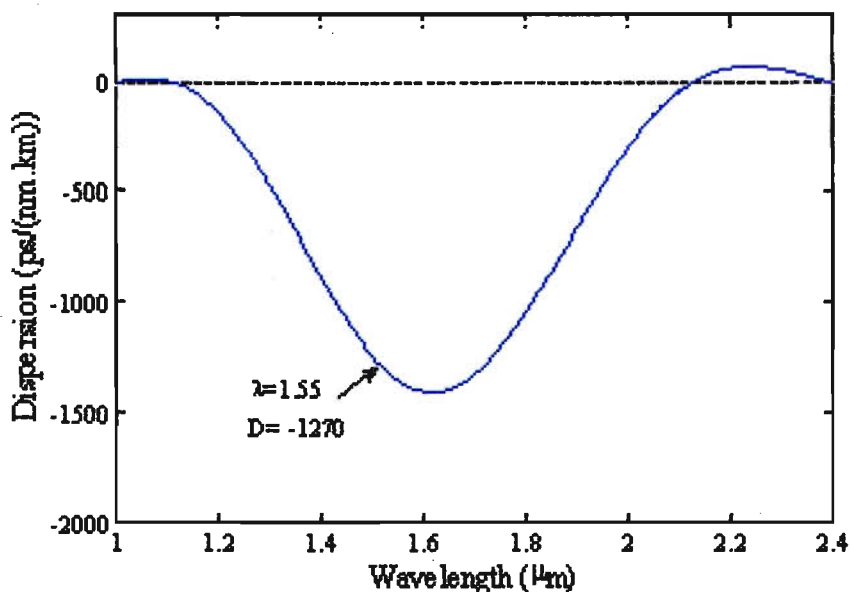

Fig. 8: Chromatic dispersion of DCF.

2.4.1.4 Negative dispersion fiber:

Small negative dispersion at 1550nm [4].

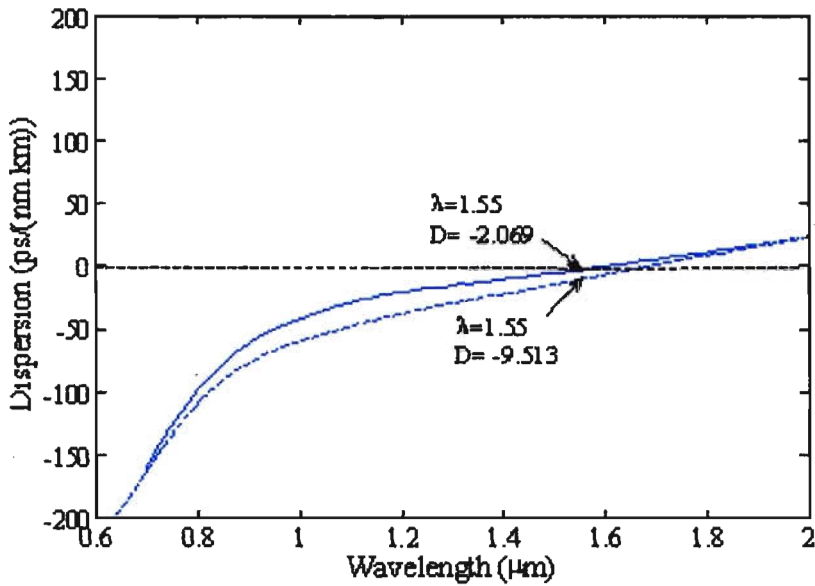

Fig. 9: Negative chromatic dispersion of NZ-DSF

2.4.2 Confinement loss:

Confinement loss is due to the finite air holes in cladding. The confinement loss is calculated from the imaginary part (Im) of the complete effective mode index n_{eff} , using the following equation [3, 5].

$$\text{Confinement Loss, } L_C = \frac{40}{\text{Im}(n_{\text{eff}})} = 8.686k_0\text{Im}(n_{\text{eff}}) \text{ [dB/km]} \quad (15)$$

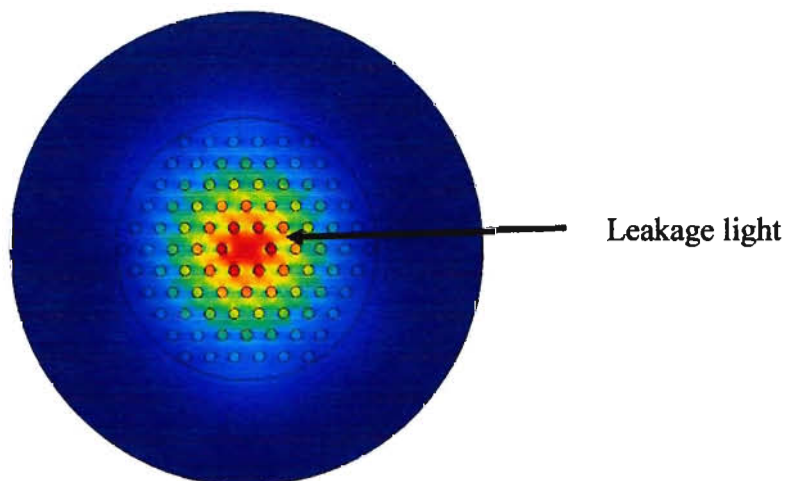

Fig. 10: Light leakages from core to cladding of the PCF.

2.4.3 Effective area:

The effective area is important parameters. It is originally introduce as the non-linear measurement. For non-linear measurement the low effective area gives a high density of power and also non-linear effects are dependent the intensity of the electromagnetic field [3, 6]. The intensity I , over the core area A_{core} can be calculated from the power, P_{means} define as:

$$I = \frac{P_{means}}{A_{core}} \quad (16)$$

We can calculate the effective area by using the following equation

$$A_{eff} = \frac{2\pi(\int_0^{\infty} |E(r)|^2 r dr)^2}{\int_0^{\infty} |E(r)|^4 r dr} \quad (17)$$

Where $E_a(r)$ is the field amplitude at radius r .

However the effective area is related to the mode field diameter (MFD) and spot size w , which is Gaussian function radius at the $1/e^2$ amplitude point. In this case the effective area shown as:

$$A_{eff} = \pi w^2 \quad (18)$$

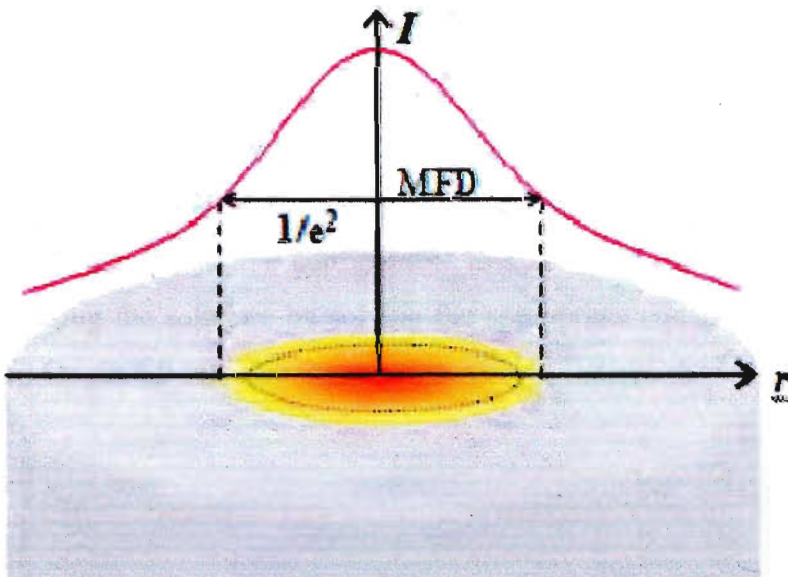

Fig. 11: Effective area (yellow part).

Dispersion Compensating Photonic Crystal Fiber

3.1 Introduction

3.2 Results and discussion

3.3 Conclusion

3.1 Introduction

Comsol multiphysics 4.3b is used as a simulation tool with anisotropic perfectly matched layer (PML) boundary condition for designing and simulating photonic crystal fiber (PCF). It is considered the most efficient boundary condition for the PCF simulation. We have designed a hexagonal model of photonic crystal fiber using Comsol which is described in sub-section 3.1.1. In this case, we have changed different parameters- diameter of air hole d and pitch A to observe the effects of different properties of PCF such as effective mode index, effective area, confinement loss and chromatic dispersion. We have achieved real part and the imaginary part of effective mode index after simulation which is then used to calculate confinement loss and chromatic dispersion [7]. Using the real part of the effective mode index we have calculated the chromatic dispersion and the imaginary part of the effective mode index are used to calculate the confinement loss of PCF. The effective area can be calculated directly using the software by solving the appropriate equation. We have plotted all the graphs using Origin 6.0 software.

3.1.1 Model

For our research purpose we designed a model of HPCF where cladding consists of five rings of air holes in hexagonal shape and a solid core which is shown in Fig 1. Air hole diameter is represented as (d) and the distance between two air holes known as pitch is represented as (Λ) respectively. As we know, all light does not always go through the core of the fiber and some light might reflect and create a distortion, in order to minimize distortion we use perfectly matched layer (PML) outside the cladding so that it can absorb the loss light and not reflect to create distortion. In our research we changed the value of pitch and the diameter of air hole to see the effect on effective mode index (n_{eff}), the change in confinement loss (dB) and the effect on effective area.

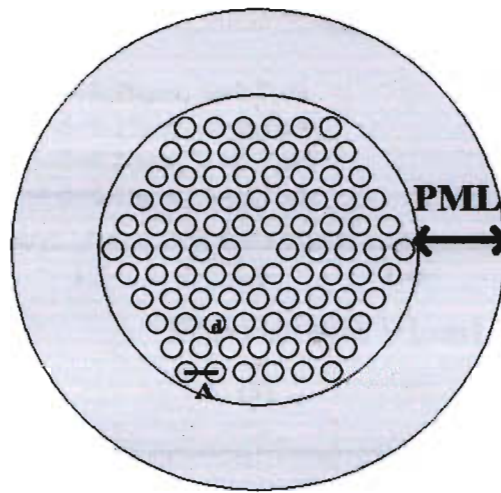

(a)

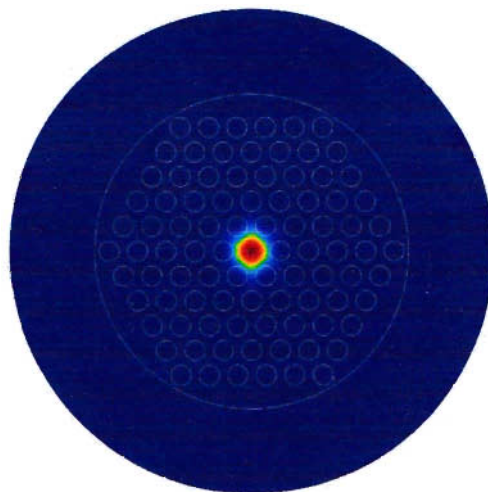

(b)

Fig.12: (a) PCF fiber with five rings of air hole with diameter d , pitch Λ and PML layer. (b) Simulated figure of PCF with light passing through the center of the core of the fiber.

3.2 Results and discussion

3.2.1. Results

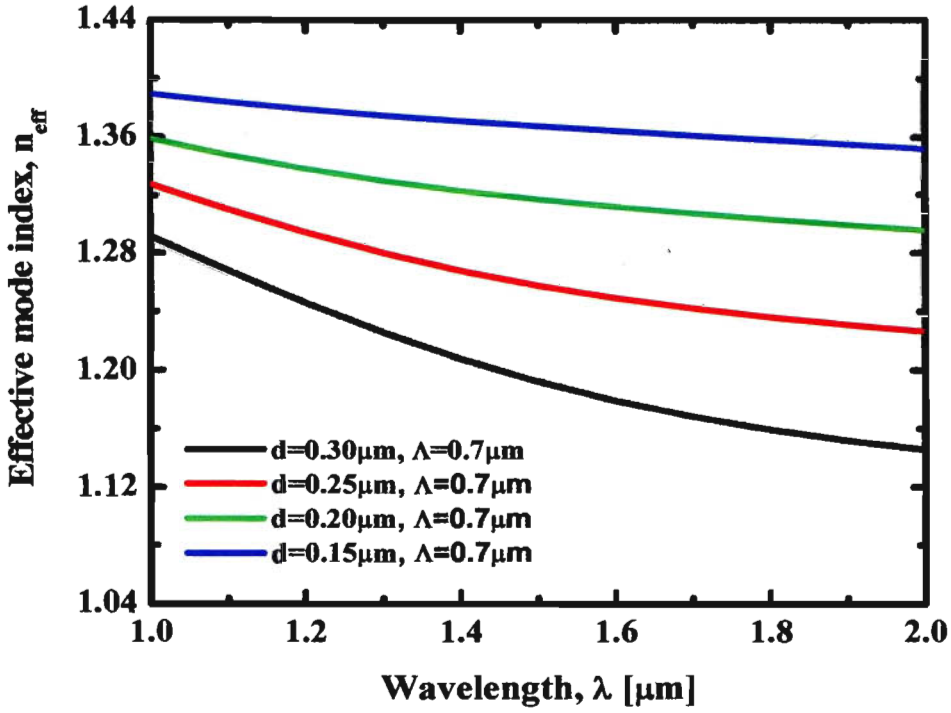

(a)

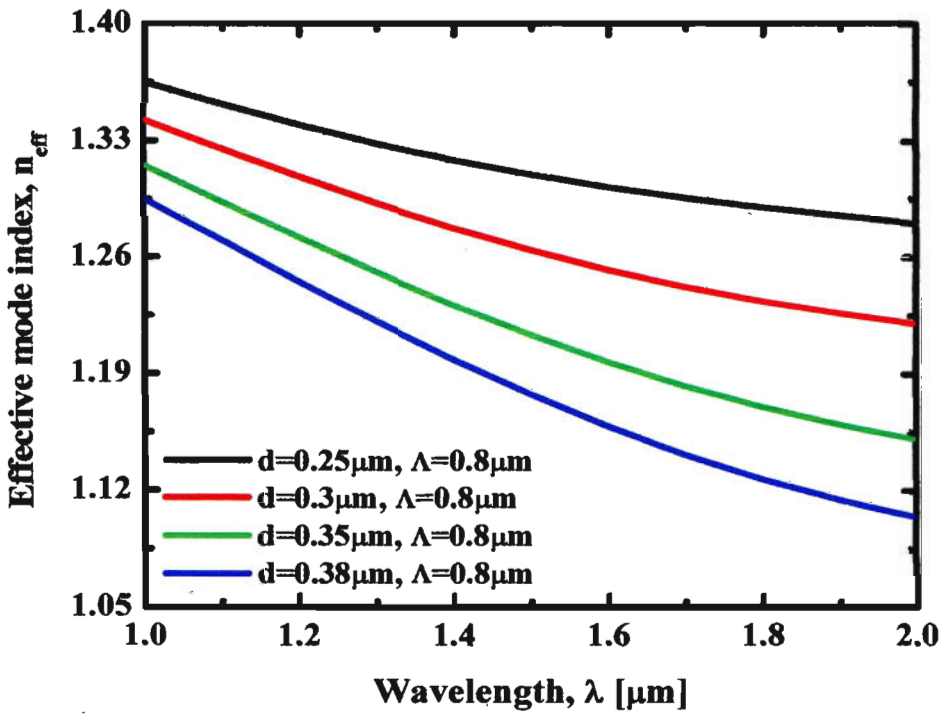

(b)

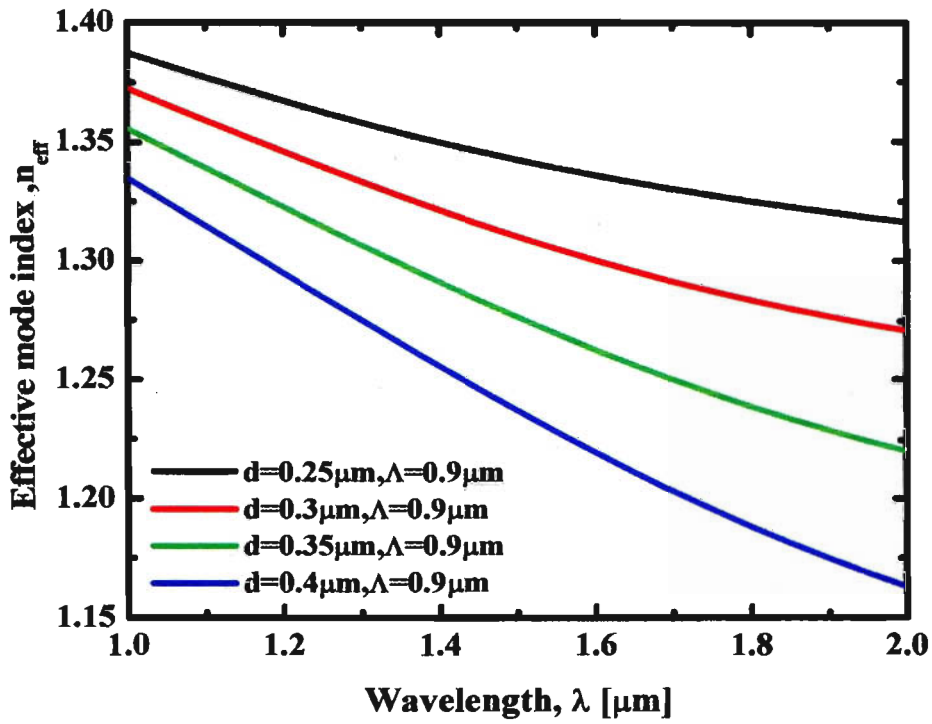

(c)

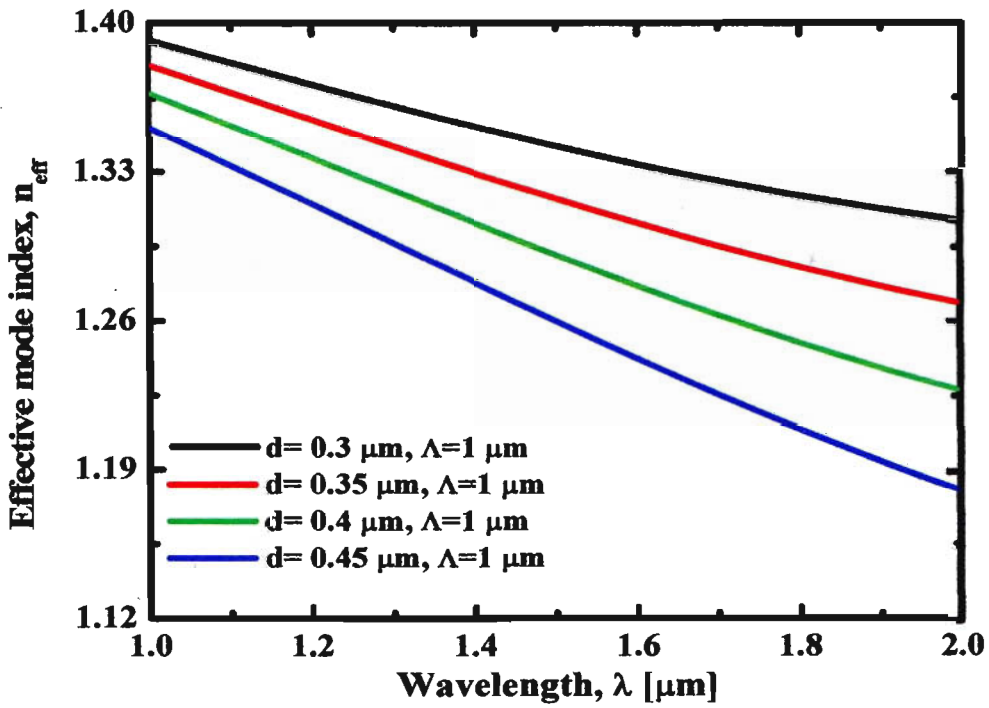

(d)

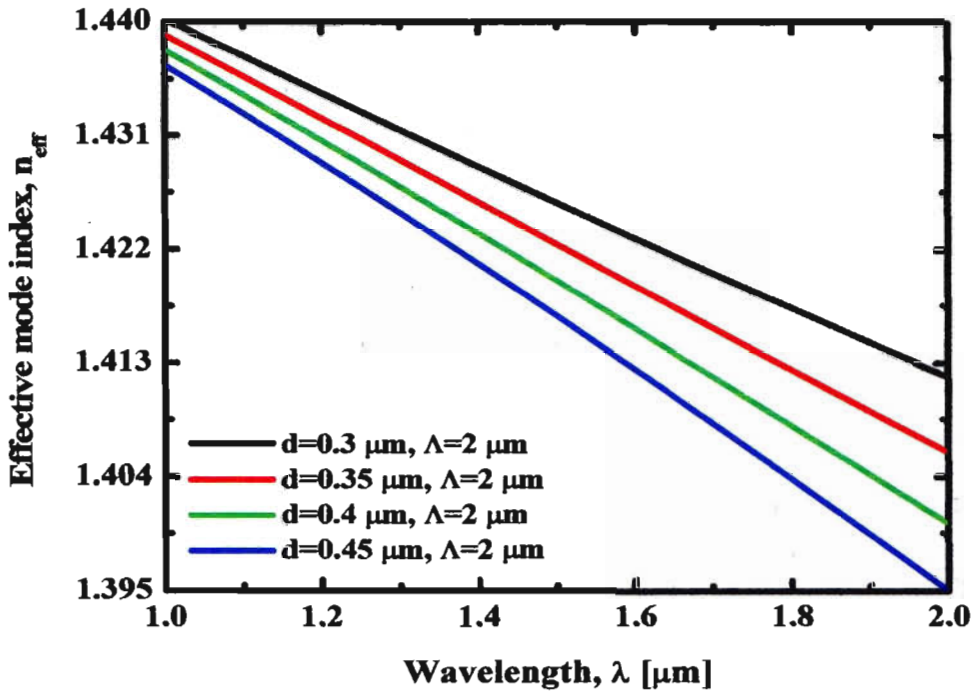

(e)

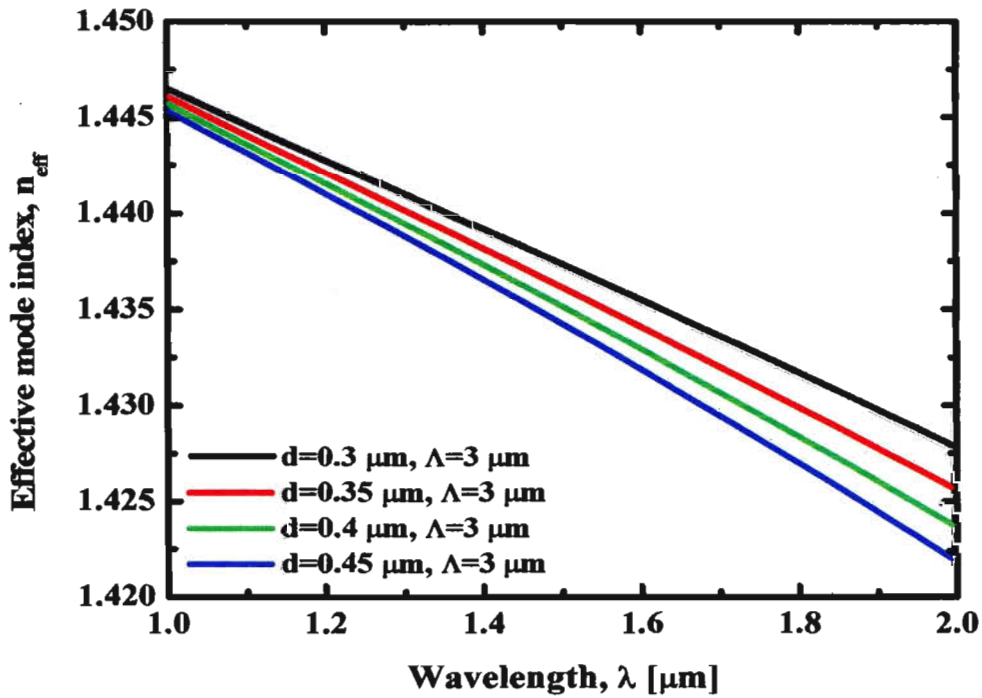

(f)

Fig. 13: Wavelength dependence effective mode index for (a) $\Lambda = 0.7$, $d = 0.25 \mu\text{m}$, $0.30 \mu\text{m}$, $0.35 \mu\text{m}$, $0.40 \mu\text{m}$, and (b) $\Lambda = 0.8$, $d = 0.25 \mu\text{m}$, $0.30 \mu\text{m}$, $0.35 \mu\text{m}$, $0.38 \mu\text{m}$ (c) $\Lambda = 0.9$, $d = 0.25 \mu\text{m}$, $0.3 \mu\text{m}$, $0.35 \mu\text{m}$, $0.4 \mu\text{m}$ (d) $\Lambda = 1.0$, $d = 0.3 \mu\text{m}$, $0.35 \mu\text{m}$, $0.4 \mu\text{m}$, $0.45 \mu\text{m}$ (e) $\Lambda = 2$, $d = 0.3 \mu\text{m}$, $0.35 \mu\text{m}$, $0.4 \mu\text{m}$, $0.45 \mu\text{m}$, and (f) $\Lambda = 3$, $d = 0.3 \mu\text{m}$, $0.35 \mu\text{m}$, $0.4 \mu\text{m}$, $0.45 \mu\text{m}$.

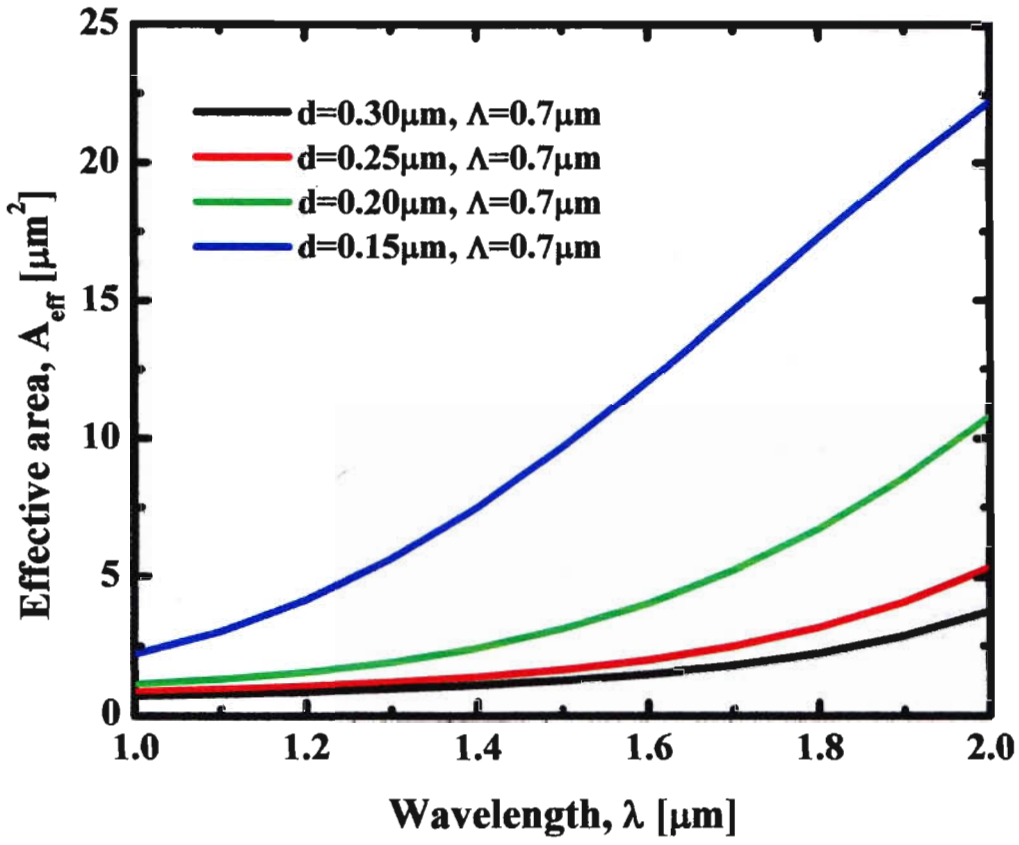

(a)

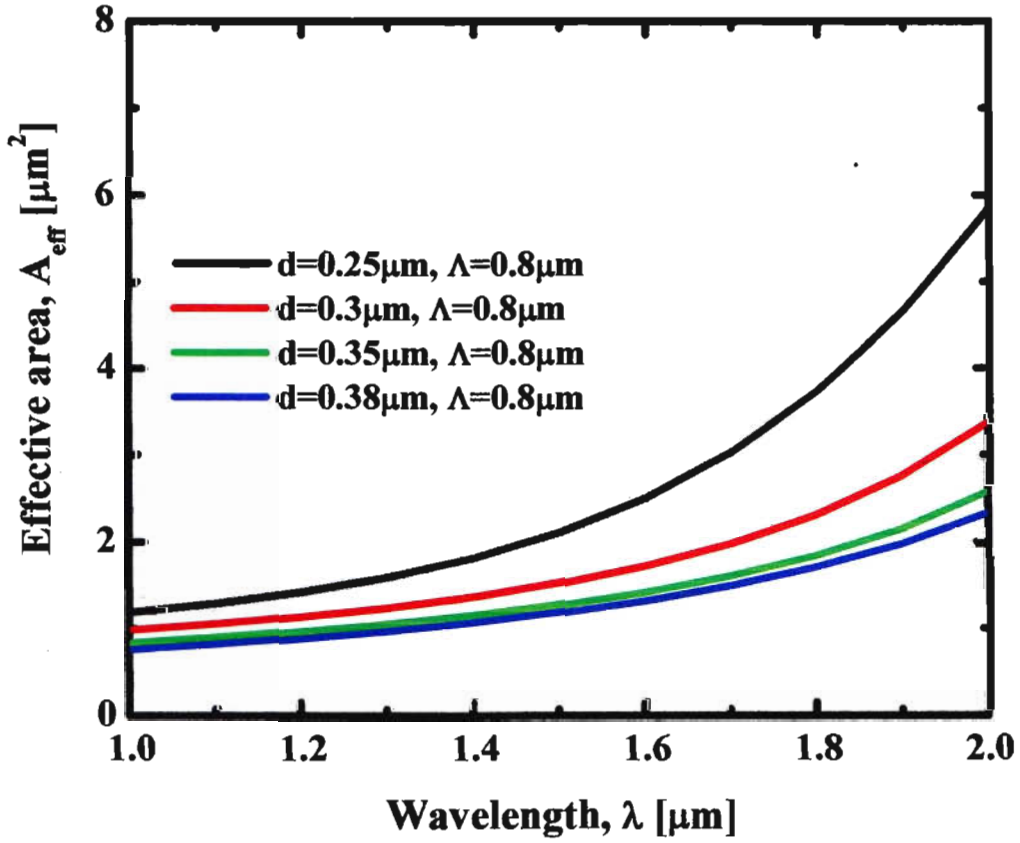

(b)

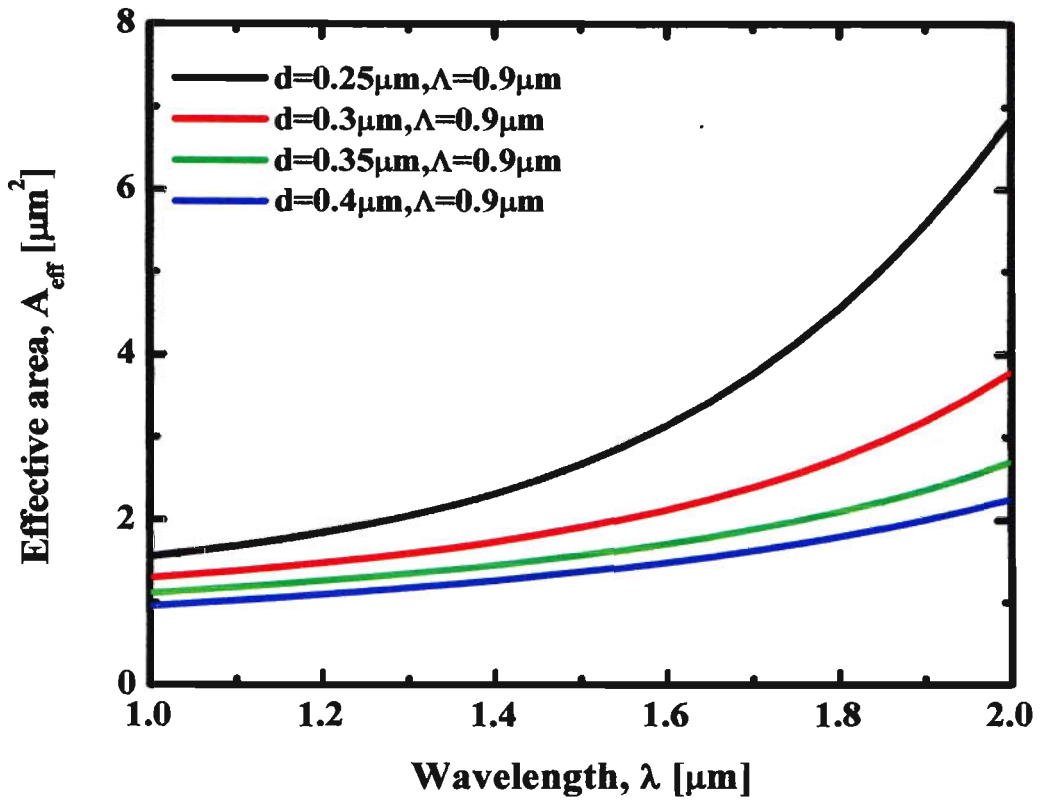

(c)

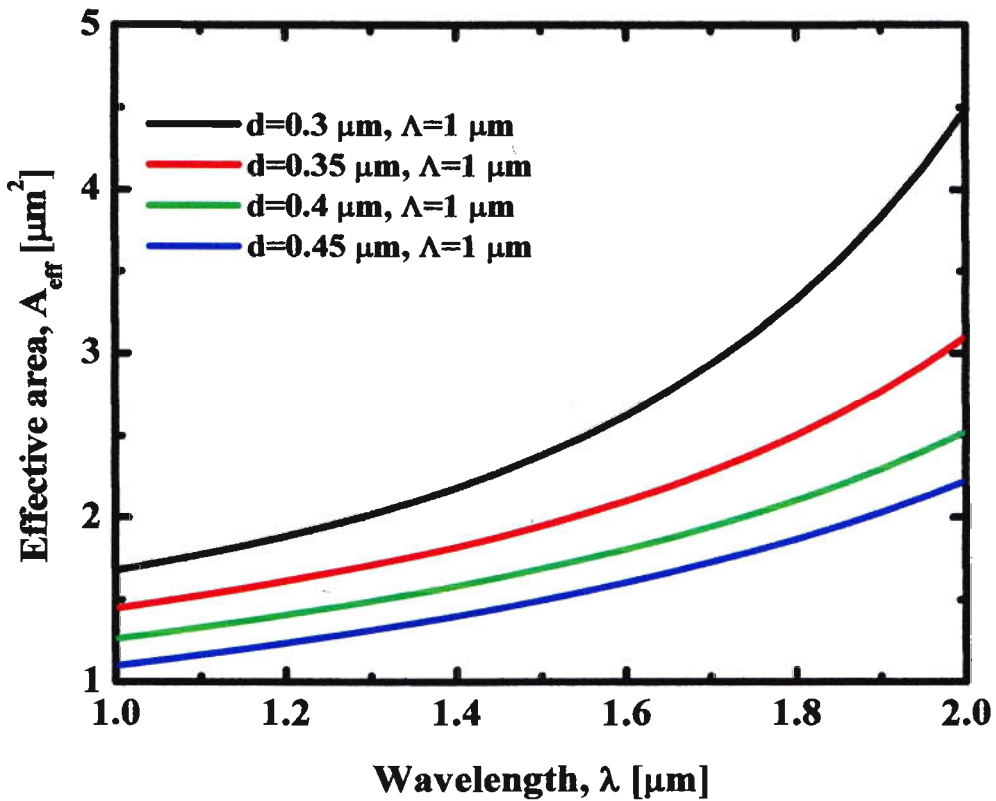

(d)

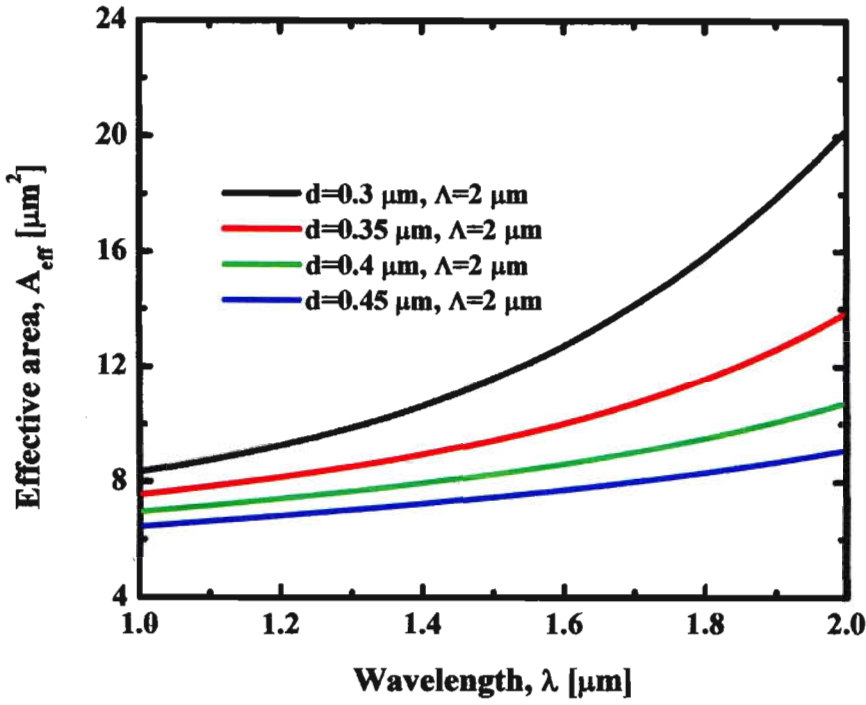

(e)

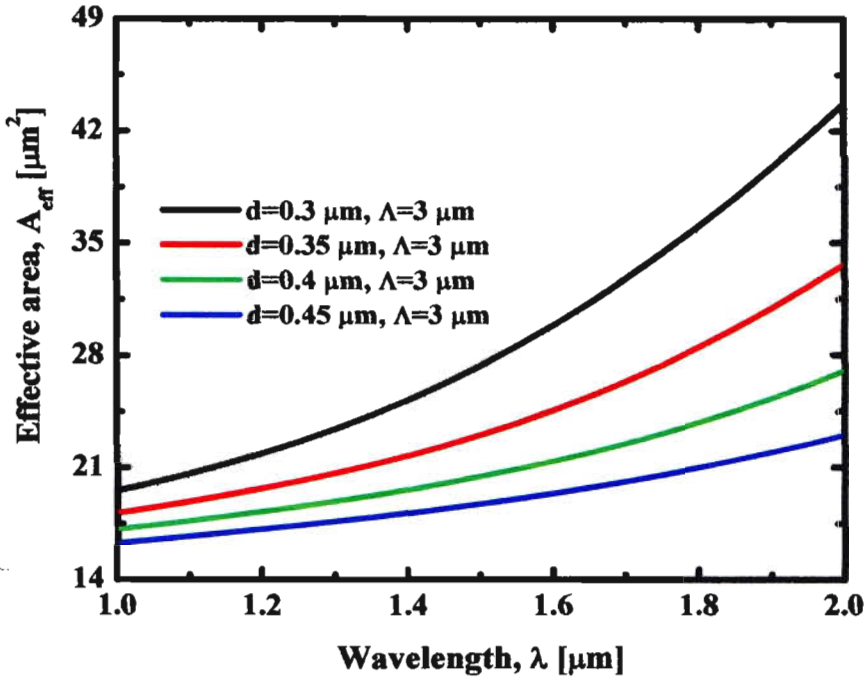

(f)

Fig. 14: Wavelength dependence effective area for (a) $\Lambda = 0.7$, $d = 0.30 \mu\text{m}$, $0.25 \mu\text{m}$, $0.20 \mu\text{m}$, $0.15 \mu\text{m}$, and (b) $\Lambda = 0.8$, $d = 0.38 \mu\text{m}$, $0.35 \mu\text{m}$, $0.3 \mu\text{m}$, $0.25 \mu\text{m}$ (c) $\Lambda = 0.9$, $d = 0.25 \mu\text{m}$, $0.3 \mu\text{m}$, $0.35 \mu\text{m}$, $0.4 \mu\text{m}$, and (d) $\Lambda = 1.0$, $d = 0.3 \mu\text{m}$, $0.35 \mu\text{m}$, $0.4 \mu\text{m}$, $0.45 \mu\text{m}$.(e) $\Lambda = 2$, $d = 0.3 \mu\text{m}$, $0.35 \mu\text{m}$, $0.4 \mu\text{m}$, $0.45 \mu\text{m}$, and (f) $\Lambda = 3$, $d = 0.3 \mu\text{m}$, $0.35 \mu\text{m}$, $0.4 \mu\text{m}$, $0.45 \mu\text{m}$.

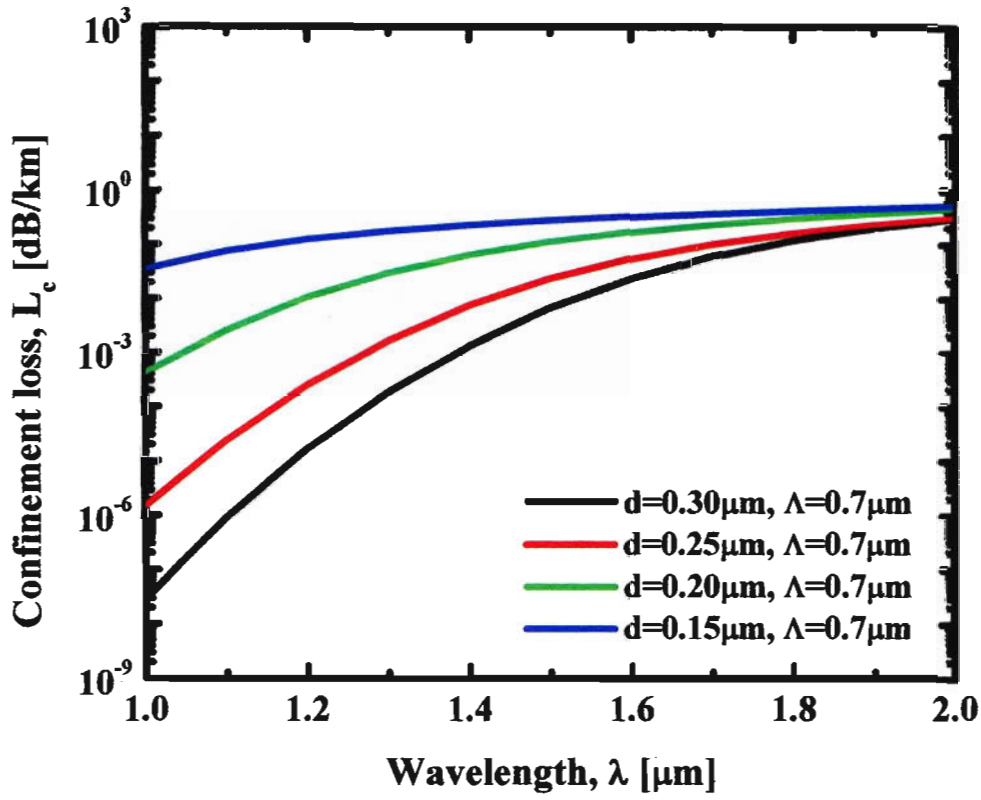

(a)

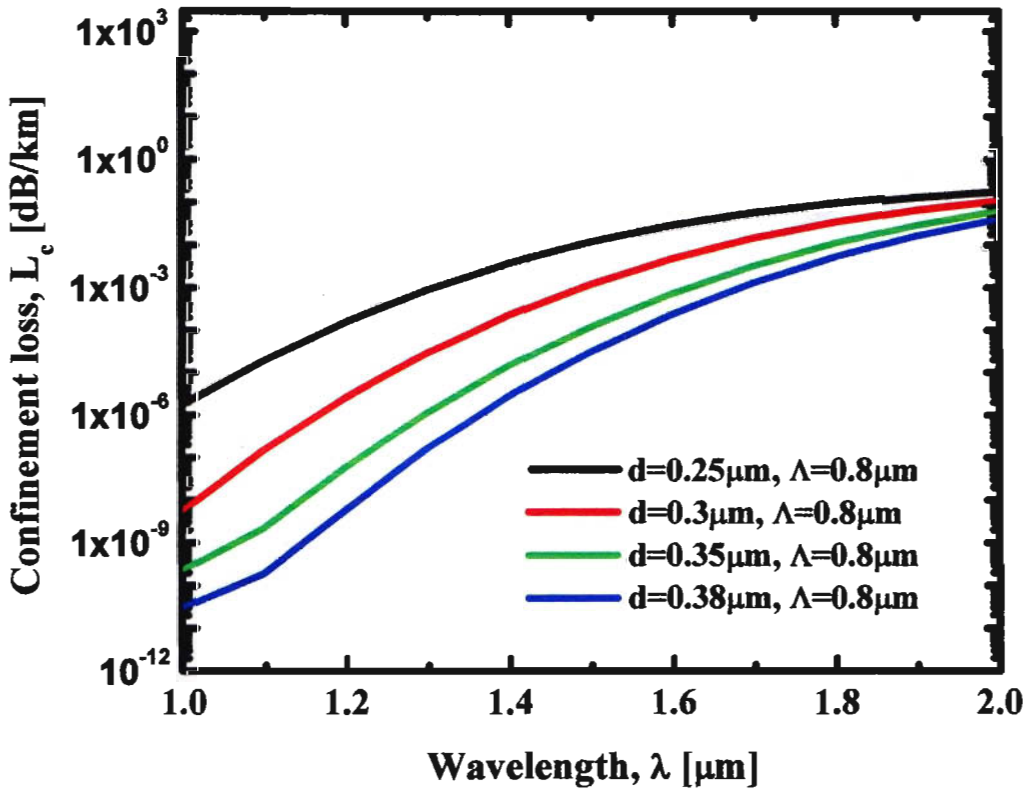

(b)

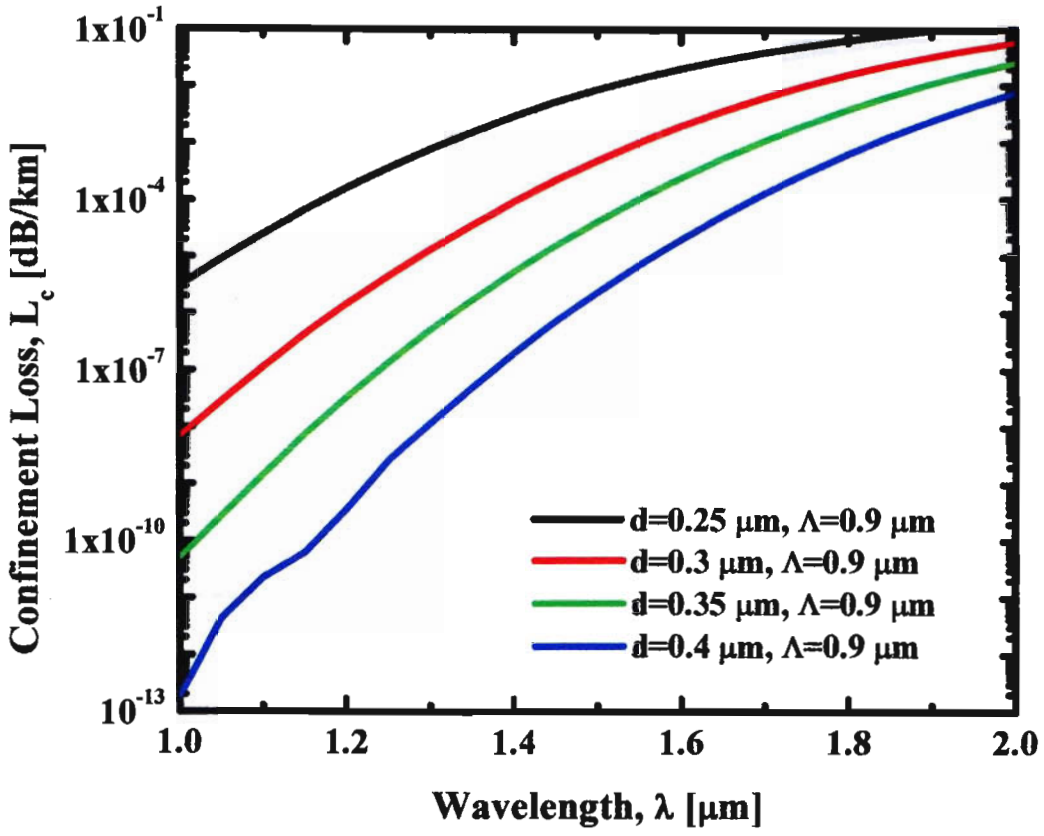

(c)

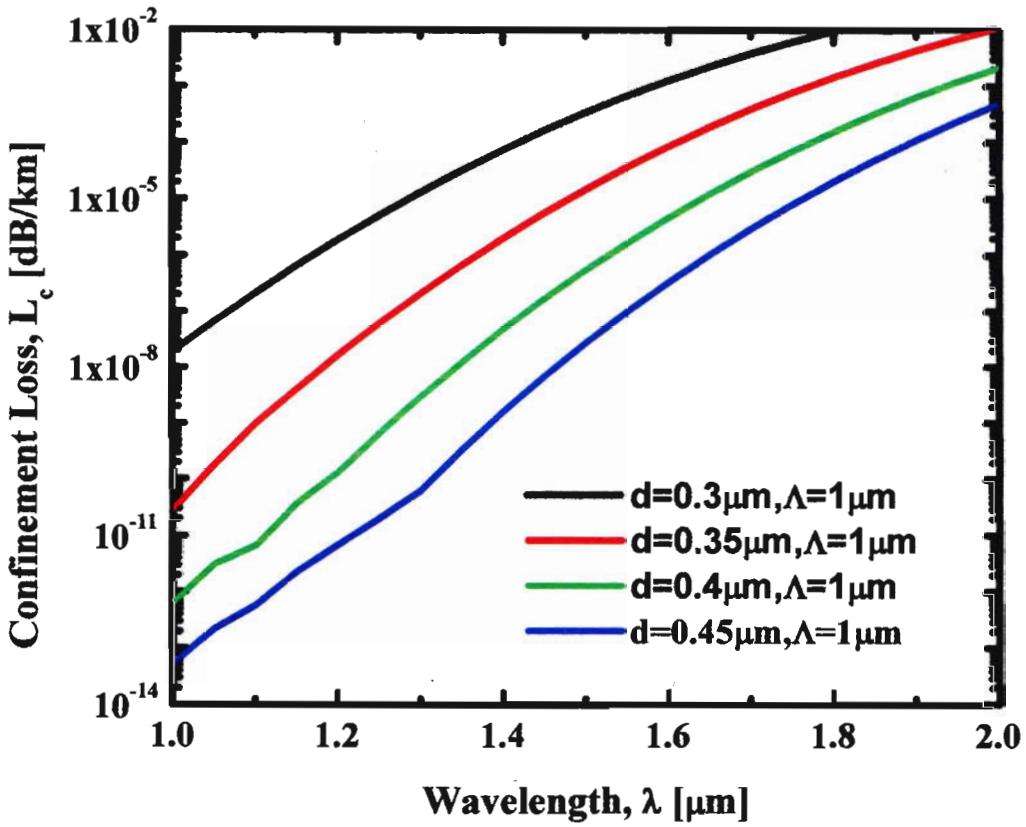

(d)

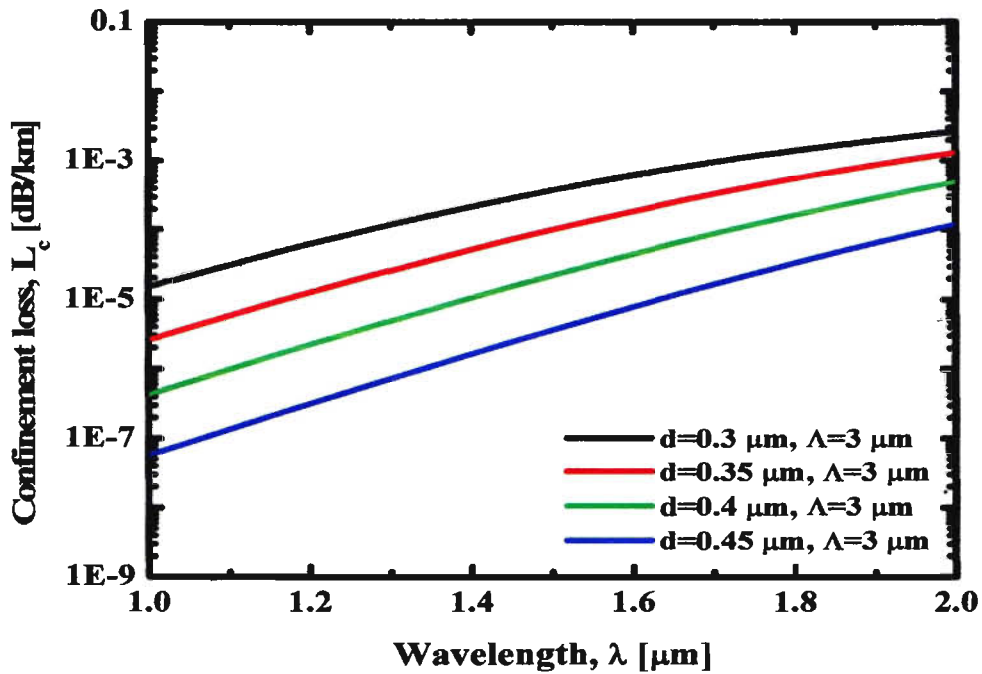
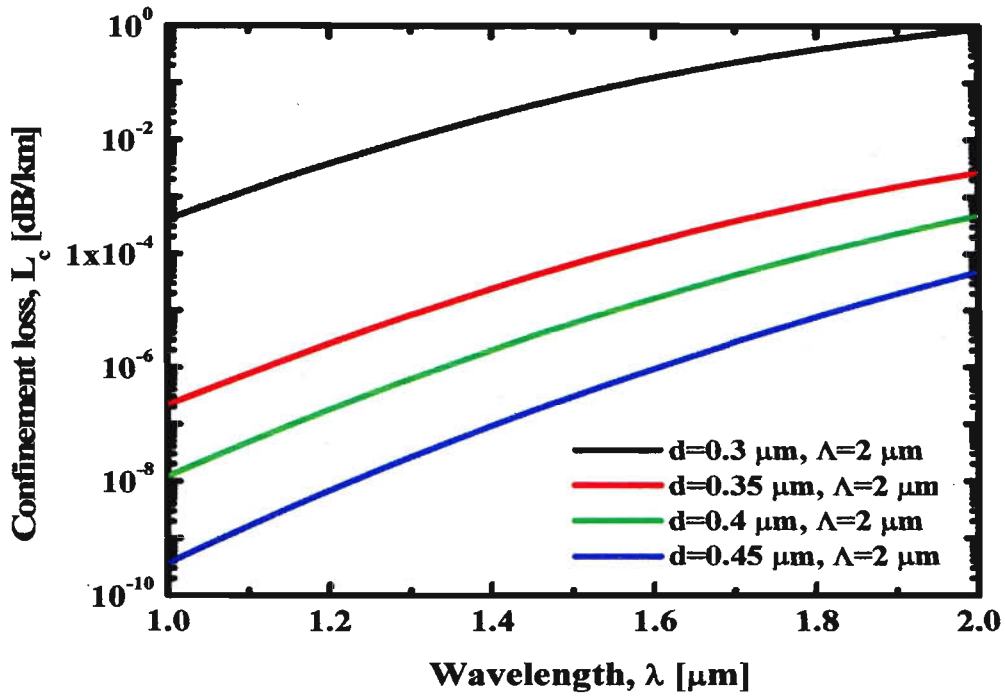
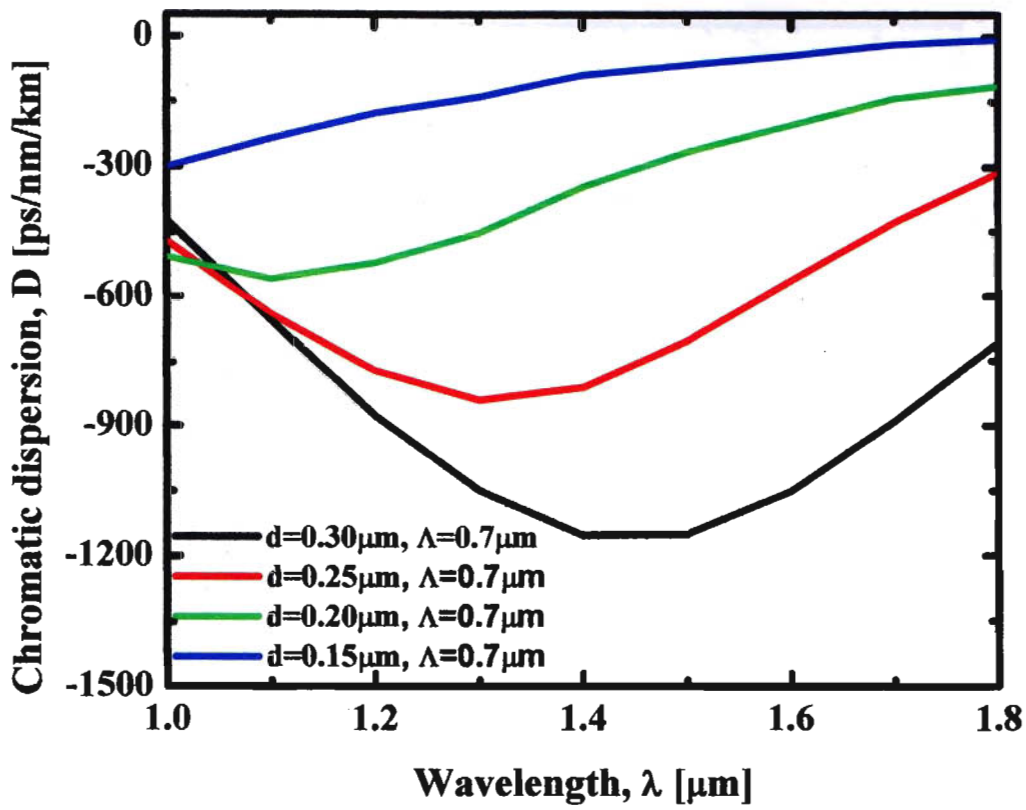
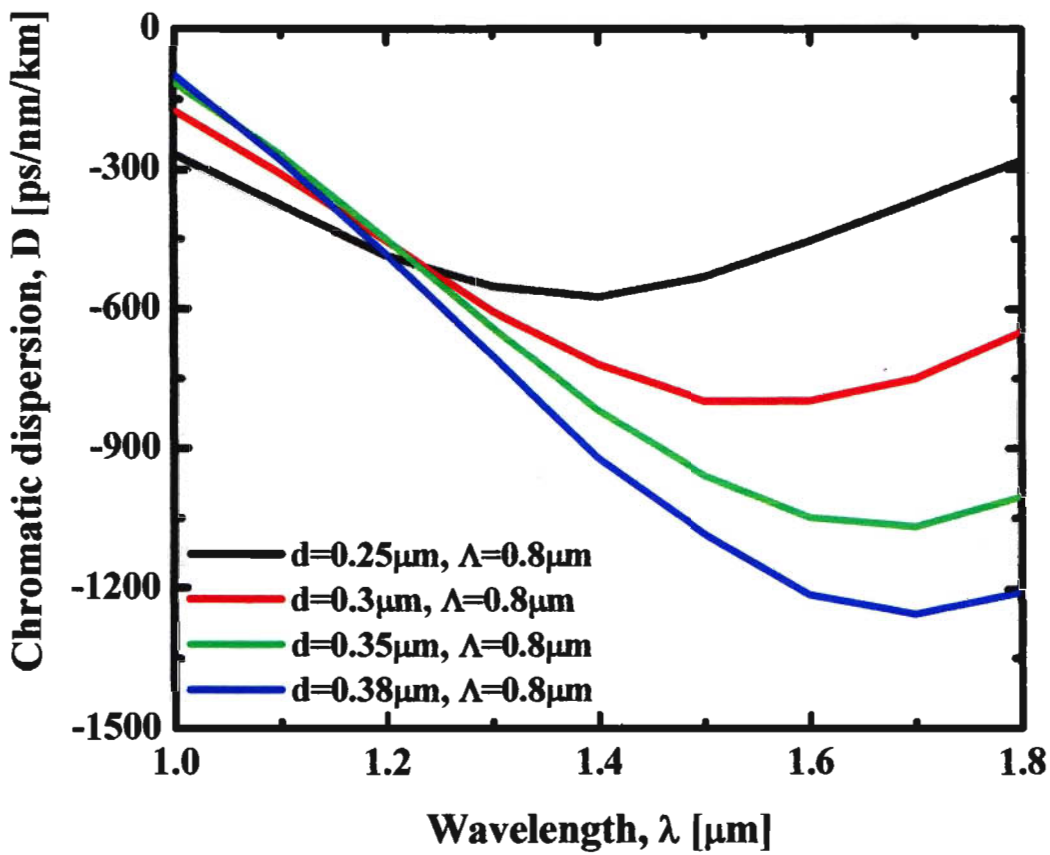

Fig. 15: Wavelength dependence confinement loss for (a) $\Lambda = 0.7$, $d = 0.30 \mu\text{m}$, $0.25 \mu\text{m}$, $0.20 \mu\text{m}$, $0.15 \mu\text{m}$, and (b) $\Lambda = 0.8$, $d = 0.38 \mu\text{m}$, $0.35 \mu\text{m}$, $0.3 \mu\text{m}$, $0.25 \mu\text{m}$ (c) $\Lambda = 0.9$, $d = 0.25 \mu\text{m}$, $0.3 \mu\text{m}$, $0.35 \mu\text{m}$, $0.4 \mu\text{m}$, and (d) $\Lambda = 1.0$, $d = 0.3 \mu\text{m}$, $0.35 \mu\text{m}$, $0.4 \mu\text{m}$, $0.45 \mu\text{m}$.(e) $\Lambda = 2$, $d = 0.3 \mu\text{m}$, $0.35 \mu\text{m}$, $0.4 \mu\text{m}$, $0.45 \mu\text{m}$, and (f) $\Lambda = 3$, $d = 0.3 \mu\text{m}$, $0.35 \mu\text{m}$, $0.4 \mu\text{m}$, $0.45 \mu\text{m}$.



(a)



(b)

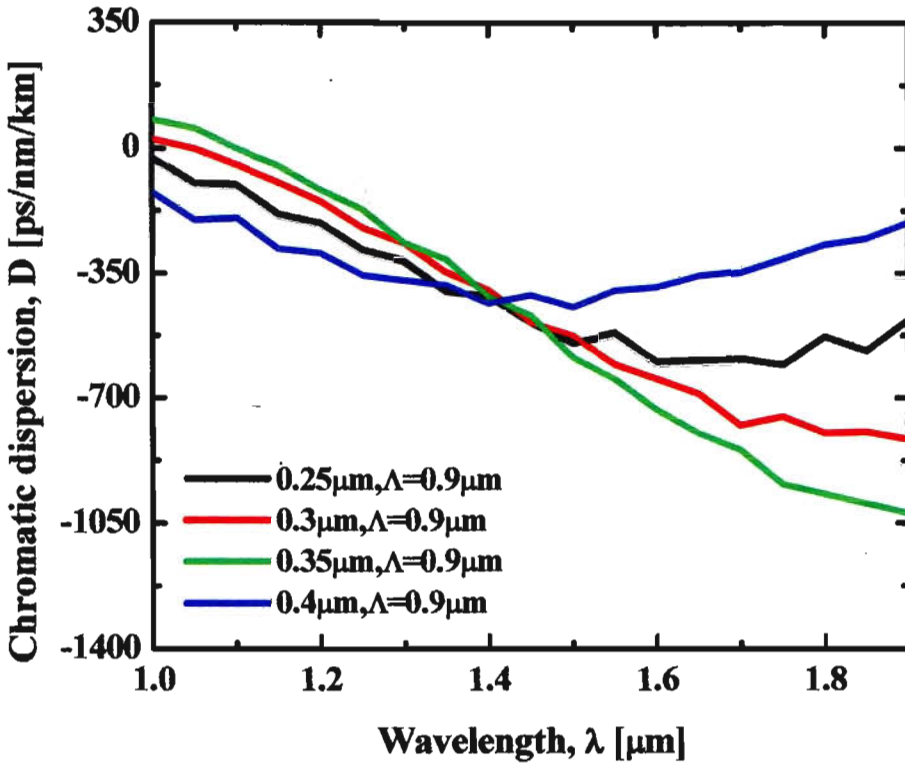

(c)

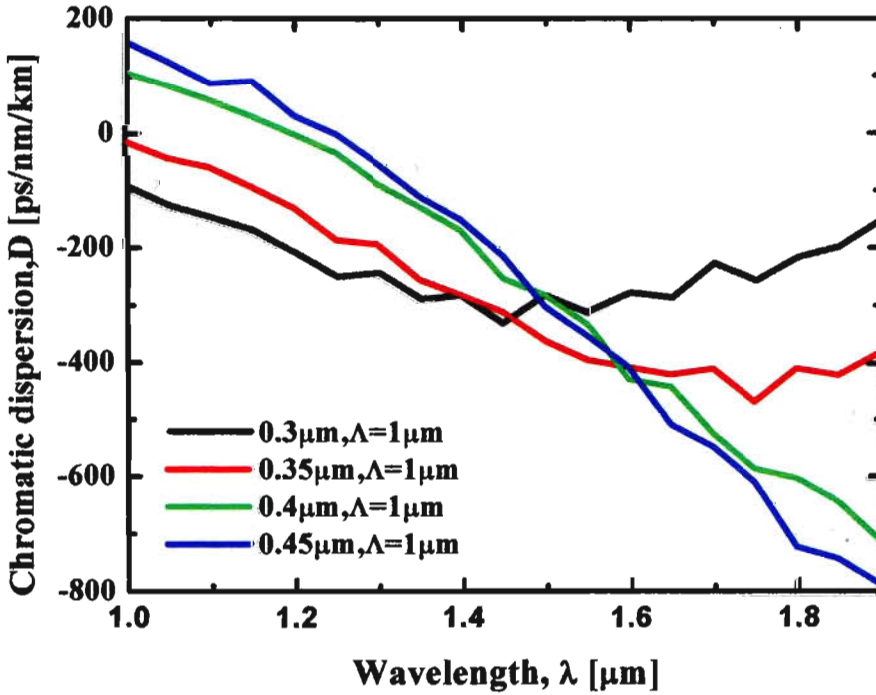

(d)

Fig. 16: Wavelength dependence chromatic dispersion for (a) $\Lambda = 0.7$, $d = 0.30 \mu\text{m}$, $0.25 \mu\text{m}$, $0.20 \mu\text{m}$, $0.15 \mu\text{m}$, and (b) $\Lambda = 0.8$, $d = 0.38 \mu\text{m}$, $0.35 \mu\text{m}$, $0.3 \mu\text{m}$, $0.25 \mu\text{m}$ (c) $\Lambda = 0.9$, $d = 0.25 \mu\text{m}$, $0.3 \mu\text{m}$, $0.35 \mu\text{m}$, $0.4 \mu\text{m}$, and (d) $\Lambda = 1.0$, $d = 0.3 \mu\text{m}$, $0.35 \mu\text{m}$, $0.4 \mu\text{m}$, $0.45 \mu\text{m}$.

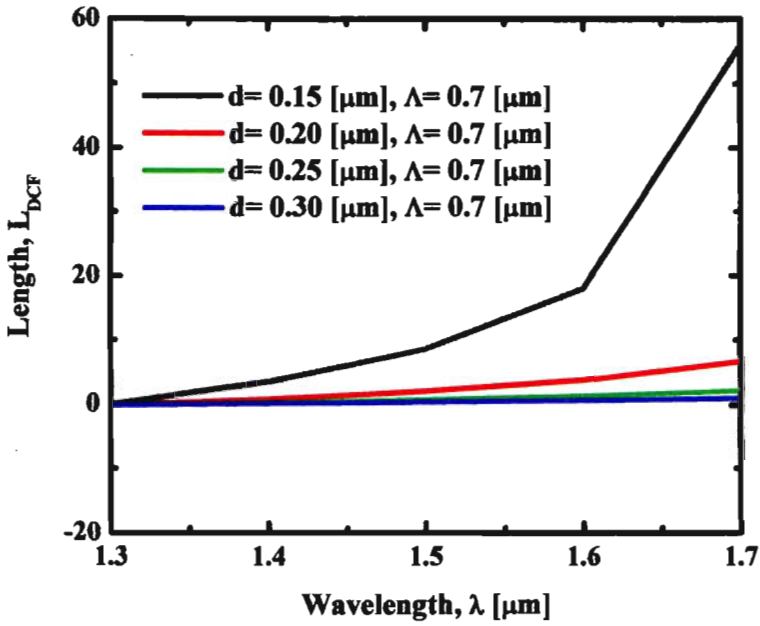

(a)

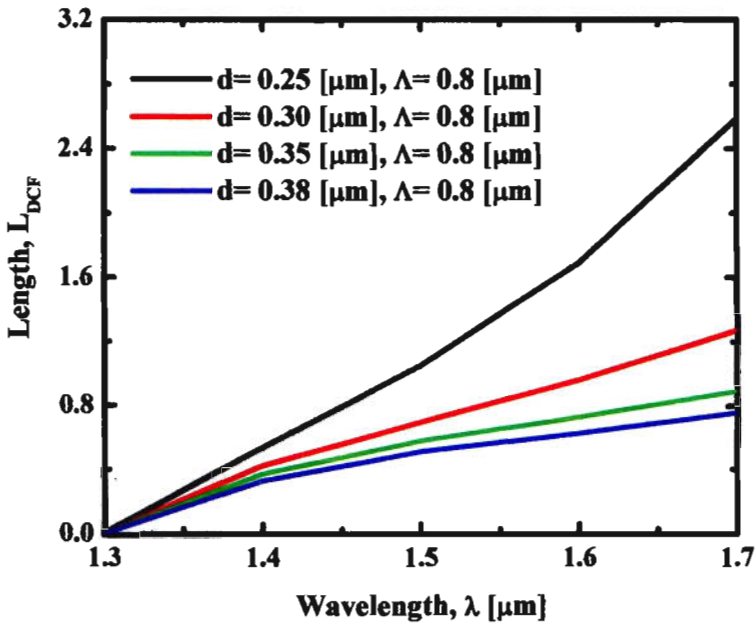

(b)

Fig. 17: Length dependence chromatic dispersion for (a) $\Lambda = 0.7$, $d = 0.15 \mu\text{m}$, $0.20 \mu\text{m}$, $0.25 \mu\text{m}$, $0.30 \mu\text{m}$, and (b) $\Lambda = 0.8$, $d = 0.25 \mu\text{m}$, $0.30 \mu\text{m}$, $0.35 \mu\text{m}$, $0.38 \mu\text{m}$.

3.2.2. Discussion

Figure 13 (a), (b), (c), (d), (e) and (f) shows the wavelength response of the real part of the effective mode index of hexagonal photonic crystal fiber (HPCF) for the parameters pitch, $\Lambda = 0.7 \mu\text{m}$, $0.8 \mu\text{m}$, $0.9 \mu\text{m}$, $1.0 \mu\text{m}$, $2 \mu\text{m}$ and $3 \mu\text{m}$ respectively. The diameter of the air hole, d is changed from $0.3\mu\text{m}$ to $0.45 \mu\text{m}$ for all cases keeping the value of pitch constant. It is seen that pitch and the diameter of the air hole has an effect on the effective mode index. We have seen from the Fig. 13 above that higher the value of the pitch larger the value of effective mode index. It is because as the value of pitch increases the amount of silica index increases, hence we see the value of effective mode index increases. Moreover, it is also observed that when we change the diameter of the air hole keeping the pitch constant, for larger value of diameter the value of effective mode index decreases, this is because as we increase the diameter of the air hole the value of silica index decreases, hence effective mode index decreases with increase in value of diameter of air hole. Furthermore, it is seen that wavelength also has an effect on the effective mode index, with the increase in the wavelength the value of effective mode index decreases.

Figure 14 (a), (b), (c), (d), (e) and (f) represents the wavelength response of the real part of the effective area of hexagonal photonic crystal fiber (HPCF) for the parameters pitch, $\Lambda = 0.7 \mu\text{m}$, $0.8 \mu\text{m}$, $0.9 \mu\text{m}$, $1.0 \mu\text{m}$, $2 \mu\text{m}$ and $3 \mu\text{m}$ respectively. The diameter of the air hole, d is changed from $0.3\mu\text{m}$ to $0.45 \mu\text{m}$ for all cases keeping the pitch value constant. It is seen that pitch and the diameter of the air hole has an effect on the effective area. We have seen from the Fig. 14 above that higher the value of pitch larger the value of effective mode index. It is because as the value of pitch increases the Gaussian function radius increases which increase the effective area. Moreover, it is also observed that for larger value of diameter the value of effective area decreases, this is because as we increase the diameter of the air hole the value of Gaussian response decreases, hence effective area decreases with increase in value of diameter of air hole. Furthermore, it is seen that wavelength also has an effect on the effective mode index, with the increase in the wavelength the value of effective mode index increases.

Figure 15(a), (b), (c), (d), (e) and (f) Reveals the wavelength response of the confinement loss of hexagonal photonic crystal fiber (HPCF). From the Fig. 15 above it is seen that higher the value of pitch larger the value of confinement loss. It is because as the value of pitch increases the leakage of light increases, hence we have seen the value of confinement loss

increases. Moreover, it is also observed that when we change the diameter of the air hole keeping the pitch constant, for larger value of diameter the value of confinement loss decreases, this is because as we increase the diameter of the air hole the amount of leakage light decreases, hence confinement loss decreases with increase in value of diameter of air hole.

Figure 16(a), (b), (c), (d), (e) and (f) embodied the wavelength response of chromatic dispersion of proposed hexagonal photonic crystal fiber (HPCF) for the parameters pitch, $A = 0.7 \mu\text{m}$, $0.8 \mu\text{m}$, $0.9 \mu\text{m}$, $1.0 \mu\text{m}$, $2 \mu\text{m}$ and $3 \mu\text{m}$ respectively. The diameter of air hole, d is changed from $0.15 \mu\text{m}$ to 0.45 for all cases the pitch is constant. It is seen that the real part of effective mode index has an effect on the chromatic dispersion. It can observe that the dispersion is technically varied with the variation of pitch.

Figure 17(a) and (b) represents the change in length with the value of chromatic dispersion. The length of the dispersion compensating fiber L_{DCF} can be calculated from the given formula. Here we have considered $D_r = 0$.

$$D_r = D_{SMF} L_{SMF} + D_{PCF} L_{PCF} \quad (19)$$

From graph (b) we can see that at diameter of air holes, $d = 0.38 \mu\text{m}$ and pitch, $A = 0.8 \mu\text{m}$ we get less value of length then that of at $d = 0.35 \mu\text{m}$ and $A = 0.8 \mu\text{m}$. As we have seen before at $d = 0.38 \mu\text{m}$ and pitch, $A = 0.8 \mu\text{m}$ we get the optimum value of chromatic dispersion and respect to that we achieved the shorter value of length, L_{PCF} . Hence, we can say the more negative value of chromatic dispersion is achieved the shorter length of dispersion compensating fiber. Shorter length of dispersion compensating fiber is preferable since it is cost effective and there is less fabrication complexity.

3.3 Conclusion

In this chapter, we have noticed that the effective mode index, effective area and confinement loss depends on the diameter of the air hole d as well as on the pitch Λ . We have seen as we increase the diameter of the air hole keeping the pitch constant the effective mode index the effective area and the confinement loss decreases. Moreover, pitch is varied keeping the diameter of the air hole constant to see the effect on the effective mode index, effective area and confinement loss. It is seen that as we increase the value of pitch the effective mode index, the effective area and the confinement loss also increases.

Conclusion

In this thesis, we have proposed hexagonal photonic crystal fiber (HPCF) with five rings of air hole. Our approach was to achieve negative dispersion for dispersion compensating fiber, which is used for optical communication system. In order to do so we have changed different parameters such as air hole diameter and pitch and observed the variation of different properties such as effective mode index, effective area, confinement loss and chromatic dispersion. From our research we have concluded that chromatic dispersion varies with the real part of the effective index along with the wavelength. We have observed results of chromatic dispersion at 1.55 μm wavelength for communication system, because of the minimum attenuation. Through our research we obtained the negative chromatic dispersion value approximately around -1205 ps/nm/km at 1.55 μm wavelength. Large negative dispersion is preferable for optical communication purpose because higher the negative value shorter the length of the dispersion compensating fiber.

References

1. John M. Senior, "Optical Fiber Communications," 3rd ed., Dorling Kindersley, India, 2010.
2. John D. Joannopoulos, Steven G. Johnson, Joshua N. Winn, Robert D. Meade, "Photonic Crystals Molding the Flow of Light," 2nd ed., Princeton University Press, Princeton, USA, 2008.
3. K. Saitoh, M. Koshiba and T. Hasegawa, E. Sasaoka, "Chromatic dispersion control in photonic crystal fibers: application to ultra-flattened dispersion," *Optic Express*, vol. 11, no. 8, pp. 843-852, 2003.
4. N. Nozhat and N. Granpayeh, "Speciality fiber designed by photonic crystal," *PIER*, vol. 99, pp. 225-244, 2009.
5. Jayprakash Vijay, Md. Sabir, "Low-flattened dispersion Hexagonal photonic crystal fiber with low confinement loss," vol. 3, no. 1, pp. 153-157, 2013.
6. Niels Asger Mortensen, "Effective area of photonic crystal fibers," *Optics Express*, vol. 10, no. 7, pp. 341-348, 2002.
7. F. Begum, Y. Namihira, S.M.A. Razzak, S. Kaijage, N.H. Hai, T. Kinjo, K. Miyagi, and N. Zou, "Novel Broadband Dispersion Compensating Photonic Crystal Fibers: Applications in High Speed Transmission Systems," *Jour. of Opt. & Laser Tech.*, vol. 41, no. 5, pp. 679-686, 2009.