



East West University

Undergraduate Thesis Report
On

**DECISIVE FACTORS & IMPACTS OF FALSE DETECTION
ON SPECTRUM SENSING IN COGNITIVE RADIO.**

By

Lailun Nahar (2009-2-80-012)

and

Sameha Zaman Ruthi (2009-2-80-020)

Submitted to the

Department of Electrical and Electronic Engineering

Faculty of Sciences and Engineering

East West University

In partial fulfillment of the requirements for the degree of
Bachelor of Science in Electrical and Electronic Engineering
(B.Sc. in EEE)

[Summer, 2013]

Approved By

Thesis Advisor

Fakir Mashuque Alamgir

Chairperson

Dr. Mohammad Mojammel Al Hakim

Approval

The thesis titled “Decisive Factors and Impacts of False Detection in Spectrum Sensing in Cognitive Radio.” submitted by Lailun Nahar and Sameha Zaman Ruthi in the semester of Summer 2013 is approved as satisfactory in partial fulfillment of the requirements for the degree of Bachelor of Science in Electrical and Electronic Engineering.

Dr. Mohammad Mojammel Al Hakim
Chairperson, Dept. of Electrical and Electronics Engineering
East West University, Dhaka.

Declaration

We, hereby declare our thesis work solely to be our own scholarly work. To the best of our knowledge, it has not been shared from any source without due acknowledgement and permission. It is being submitted in partial fulfillment of the requirements for the degree of Bachelor of Science in Electrical and Electronic Engineering. It has not been submitted before for any degree or examination in any other university.

Lailun Nahar

Sameha Zaman Ruthi

Summer Semester
August'2013.

Abstract

The increasing demand for wireless communication introduces efficient spectrum utilization challenges. Cognitive radio has emerged as the key technology to address this challenge which enables opportunistic access to the spectrum. The main potential advantages introduced by cognitive radio are improving spectrum utilization and increasing communication quality. Cooperative spectrum sensing improves the probability of detection by collaborating to detect primary user's signal in cognitive radio (CR) system as well. The goal of this thesis is to cooperate the cognitive users to increase the detection probability for a given probability of false alarm and find out the better condition of sensing spectrum among three rules: AND, Majority, OR. Here, we propose a cooperative spectrum sensing and signal detection in the CR system by implementing AND rule, Majority rule and OR rule under the AWGN channel and fading channel. To find out better detection, here we compare between AND, Majority, and OR rules. It is observed that the probability of detection for a given value of probability for the false alarm has been significantly achieved by optimal value of detection probability in AND rule, Majority rule, OR rules as the number of the user increases. Finally we also see the effects of fading over the spectrum sensing. We have observed that due to fading condition, the amplitude of signal deviates. In fading condition AND rule gives better performance in detection probability among three rules.

Keywords: Cognitive radio, Cooperative sensing, Probability of false alarm, Probability of miss detection, AND rule, OR rule, Primary and secondary user, AWGN channel, Fading.

Acknowledgements

We would like to express our heartiest and most sincere gratitude to our supervisor, Mr. Fakir Mashuque Alamgir, Senior Lecturer, Department of Electrical and Electronics Engineering, East West University for his intelligent and well thought suggestions. He provided us with every bit of support he could manage. We were allowed to work on our own and whenever we lost our way, he guided us back to track with patience and interest.

Authorization page

We hereby declare that we are the sole authors of this thesis. We authorize East West University to lend this thesis to other institutions or individuals for the purpose of scholarly research.

Lailun Nahar

Sameha Zaman Ruthi

We further authorize East West University to reproduce this thesis by photocopy or other means, in total or in part, at the request of other institutions or individuals for the purpose of scholarly research.

Lailun Nahar

Sameha Zaman Ruthi

TABLE OF CONTENTS

Chapter 1: Introduction and Fundamentals of Cognitive Radio.....	13
1.1 Introduction.....	13
1.1.1 Cognitive Radio.....	13
1.1.2 History and Background Leading to Cognitive Radio.....	14
1.1.3 Versatile nature of Cognitive Radio.....	14
1.1.4 Need of flexible wireless communication system.....	15
1.1.5 Advantages of a cognitive radio system.....	17
1.2 Features of Cognitive radio.....	18
1.2.1 Interference Management and Spectrum Sensing.....	19
1.2.2 Receiver Centric Interference Management.....	19
1.2.3 Transmitter Centric Interference Management.....	20
Chapter 2: Literature Survey.....	21
2.1 Spectrum Sensing Smart Codec Design.....	21
2.1.1 Cognitive Cycle.....	21
2.1.2 Types of Cognitive Radio.....	22
2.1.3 Modeling and Simulation of Spectrum Sensing by Smart Codec.....	23
2.2 Sensing Setup.....	23
2.2.1 Procedure for sensing the spectrum.....	26
2.2.2 Sensing Capability.....	26
2.3 Cognitive Radio Frontend.....	28
2.3.1 Signal processing techniques for spectrum sensing.....	29

2.3.2 Pros and Cons of the signal processing techniques for spectrum sensing..... 30

Chapter 3: Methodology Adopted and Justification of the Thesis..... 31

3.1 Introduction..... 31

3.2 Relation between Software defined radio and Cognitive Radio..... 31

3.3 Relation between Adaptive Radio and Cognitive Radio..... 31

3.4 Local Spectrum sensing..... 31

3.5 Probability of false alarm and probability of miss detection..... 32

3.6 Energy Efficiency Noise (AWGN)..... 32

3.7 Additive White Gaussian Noise (AWGN)..... 32

3.8 Methodology adopted of Cooperative Spectrum Sensing under AWGN..... 33

3.8.1 Soft and hard combining..... 34

3.8.2 Justification behind selecting AND rule..... 35

3.8.3 Calculation of AND and OR rule..... 36

3.8.4 Components for calculation..... 37

Chapter 4: Project Framework..... 38

4.1 Introduction..... 38

4.2 Proposed Framework for Cooperative Sensing..... 38

4.3 Work flow..... 39

4.4 Simulation setup process..... 40

Chapter 5: Result Analysis..... 42

5.1 Introduction..... 42

5.2 Result Analysis..... 42

5.3 Analysis of results for Fading Channel.....	49
5.4 Comparison of the research work with other papers and real life implementation.....	50
Chapter 6: Conclusion.....	52
6.1 Conclusion.....	52
6.2 Drawbacks.....	52
6.3 Future work on cognitive radio.....	52
REFERENCES.....	45
APPENDIX.....	46

LIST OF ILLUSTRATIONS

Figure 1.1: Technology timeline [2]..... 13

Figure 1.2: Frequency allocation for different purpose [3] 13

Figure 1.3(a): Time vs. Number of mobile users [3]..... 14

Figure 1.3(b): Time vs.Data [3]..... 15

Figure 1.4: Concept of Spectrum Holes [3]..... 16

Figure 1.5: Spectrum sharing, exchanges and merchandising [3]..... 17

Figure 1.6: Spectrum Bands [3]..... 18

Figure 2.1: Cognitive Cycle [5]..... 21

Figure 2.2: Gate level Design of the convolution Encoder [5]..... 23

Figure 2.3: Bandwidth vs BER [5]..... 24

Figure 2.4: Bandwidth vs BER [5]..... 25

Figure 2.5: Setup diagram [6]..... 26

Figure 2.6: Sensing setup [6]..... 27

Figure 2.7 Wideband RF/analog front-end architecture for cognitive radio [7].....29

Figure 3.1 Average throughput versus the number of cooperative [9]..... 33

Figure 3.2 (a) Non cooperative system [11]..... 36

Figure3.2 (b) Cooperative system [11]..... 36

Figure 4.1 Framework of centralized cooperative sensing [12]..... 38

Figure 4.2 Workflow..... 40

Figure 5.1(a) Pfa vs PmdAND for bandwidth factor 1200.....42

Figure 5.1 (b) Pfa vs Pd OR for 1200..... 42

Figure 5.2: Pfa vs Pmdmaj for bandwidth 1200..... 42

Figure 5.3(b) Pfa vs Pd OR for Bandwidth factor 2000..... 43

Figure 5.4 Pfa vs PmdMAJ for Bandwidth 2000.....	43
Figure 5.5(a) Pfa vs Pmd Andsim for minimum CR user.....	44
Figure 5.5(b) Pfa vs Pd OR sim for minimum CR user.....	44
Figure 5.5(c) Pfa vs Pdmajsim for minimum CR user.....	45
Figure 5.6(a) Pfa vs Pmd ANDsim after changing CR user to 20.....	46
Figure 5.6(b) Pfa vs Pmd ORsim after changing CR user to 20.....	46
Figure 5.6(c)Pfa vs Pmd Majsim after increasing CR user to 20.....	46
Figure 5.7 (a) Pfa vs Pmd ANDsim for increase CR user 35.....	47
Figure 5.7 (b) Pfa vs Pmd ORsim for increase CR user 35.....	47
Figure 5.7 (c) Pfa vs Pmd Majoritysim for increase CR user 35.....	48
Figure 5.8 (a):Pfa vs Pmd fadAND for fading channel.....	48
Figure 5.8 (b) Pfa vs PdfadOR for fading channel.....	49
Figure 5.8 (c) Pfa vs Pdfadmajority for fading channel.....	49
Figure 5.9 (a) Probability of detection with change of SNR.....	51
Figure 5.9 (b) Probability of Detection varying user.....	51

LIST OF TABLES

1.1 Overview Of available techniques for spectrum sensing.....31

Chapter 1

Fundamentals of Cognitive Radio

1.1 Introduction

In recent times, the advancement of next generation radio access technologies is limited by the shortage of the available radio spectrum. These new technologies are becoming even more bandwidth demanding due to their higher data rate requirements. Cognitive radio (CR) is a promising technology geared towards solving the spectrum scarcity problem by opportunistically identifying the vacant portions of the spectrum and transmitting in them. But the licensed or primary users (PUs) of the spectrum are not affected by this. This necessitates adapting to the dynamically changing spectrum resource, learning about the spectrum occupancy, making decisions on the quality of the available spectrum resource including its expected duration of use, probability of disruption caused by the primary users (Pus). Thus, CR networks help to make efficient use of the available spectrum by using bands such as television broadcast frequencies below 700MHz which have been recently marked for CR operation. Cognitive radio networks and spectrum sensing techniques are natural ways to allow these new technologies to be deployed.

1.1.1. Cognitive Radio

Cognitive Radio (CR) is an adaptive, intelligent radio and network technology that can automatically detect available channels in a wireless spectrum and change transmission parameters enabling more communications to run concurrently and also can improve radio operating behaviour. Cognitive radio networks (from now on called secondary networks) will also need to coexist with legacy ones which have the right to their spectrum slice and thus cannot accept interference.

1.1.2. History and Background leading to Cognitive Radio

The concept of cognitive radio was first proposed by Joseph Mitola III in a seminar at KTH (the Royal Institute of Technology in Stockholm) in 1998 and was published in an article by Mitola and Gerald Q. Maguire, Jr. in 1999 [1]. It was a novel approach in the wireless communication field. The sophistication possibility in a ‘Software Defined Radio’

(SDR) has now reached the level where each radio can conceivably perform profitable tasks that help the user, help the network and help minimize spectral congestion. Radios are already demonstrating one or more of these capabilities in limited ways [1]. To support the technologies and regulatory considerations three major applications make it cognitive radio. They are as follows:

- Spectrum management and optimizations.
- Interface with a wide variety of networks and optimization of network resources.
- Interface with a human and providing electromagnetic resource to aid the human in their activities.

Many technologies have come together to result in the spectrum efficiency and cognitive radio technologies. These technologies represent a wide swath of contributions upon which cognitive technologies may be considered as an application on top of a basic SDR platform which is implemented largely from digital signal processors and general-purpose processors (GPPs) built in silicon.

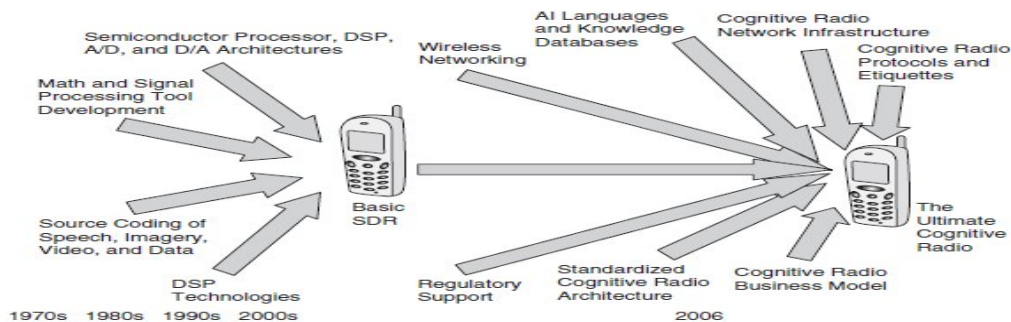

Figure 1.1: Technology Timeline: SDR becomes the platform of choice for the cognitive radio [2].

In many cases, the spectral efficiency and other intelligent support to the user arises by sophisticated networking of many radios to achieve the end behaviour which provides added capability and other profits to the user.

1.1.3. Versatile nature of Cognitive Radio

Traditional wireless systems are typically designated to operate over a certain frequency band under a well-designed transmission format and infrastructure, including Physical (PHY) layer modulation/demodulation (MODEM), channel coder/decoder (CODEC), Medium access control (MAC) protocols, and Networking infrastructure. So legacy wireless systems are

inflexible transmission format but cognitive Radio is a flexible wireless communication system.

The cognitive radio is capable to provide a wide variety of intelligent behaviour. It can monitor the spectrum and choose frequencies that minimize interference to existing communication activity. When doing so, it will follow a set of rules that defines what frequencies may be considered, what waveforms may be used, what power levels may be used for transmission, and so forth. It may also be given rules about the access protocols by which spectrum access is negotiated with spectrum license holders (if any) and the etiquettes by which it must check with other users of the spectrum to ensure that no user hidden from the node wishing to transmit is already communicating. In addition to the spectrum optimization level, the cognitive radio may have the ability to optimize a waveform to one or many criteria. For example, the radio may be able to optimize for data rate, for packet success rate, for service cost, for battery power minimization, or for some mixture of several criteria. The user does not see these levels of sophisticated channel analysis and optimization except as the recipient of excellent service.

The cognitive radio may also exhibit behaviours that are more directly apparent to the user. These behaviours may include: (a) awareness of geographical location, (b) awareness of local networks and their available services, (c) awareness of the user and the user's biometric authentication to validate financial transactions, and (d) awareness of the user and his/her prioritized objectives. The cognitive radio developer must use caution to avoid adding cognitive functionality that reduces the efficiency of the user at his or her primary tasks. If the user thinks of the radio as a cell phone and does not wish to access other networks, the cognitive radio developer must provide a design that is friendly, timely and responsive to the user. But it is not continually intruding with attempts to be helpful by connecting to networks that the user does not need or want. If the radio's owner is a power user, however, the radio may be asked to watch for multiple opportunities such as access to other wireless networks for data services, notification of critical turning points to aid navigation, or timely financial information. The cognitive radio must offer functionality that is timely and useful to its owner, and yet not disruptive.

1.1.4. Need for a flexible wireless communication system

It is commonly believed that there is a spectrum scarcity of frequencies that can be economically used for wireless communications. This problem arises from the intense

competition for use of spectrum at frequencies below 3 GHz. So, wireless channels are scarce resources. From figure 1.2 we can see the frequency allocation for various purposes.

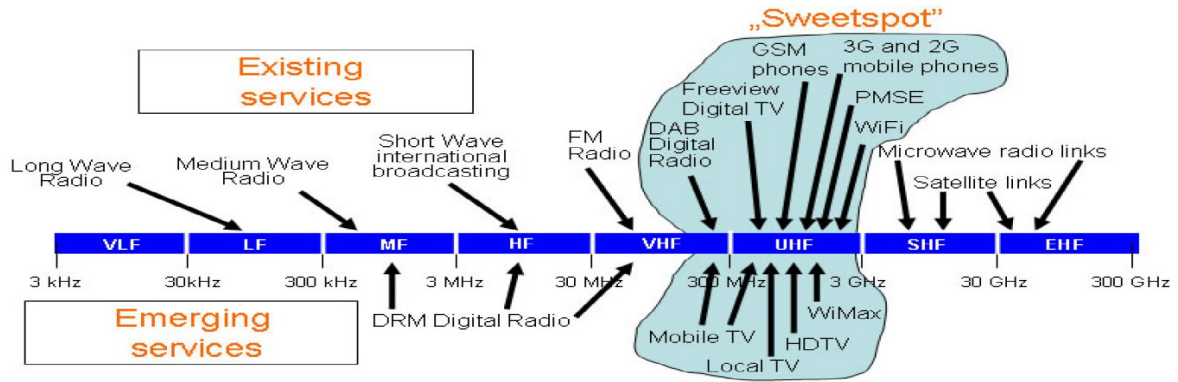

Figure 1.2: Frequency allocation for various purposes [3].

From the above figure, we can see that 3 KHz to 300 KHz are used for emergency services. Here, 300 KHz to 300MHz is allocated for DRM Digital Radio. Very High frequency (VHF) which starts from 30 MHz to 300 MHz is allocated for FM Radio. Sweet-spot for radio transmissions: 200MHz ~ 3GHz. TV, microwave ovens, mobile phones, Wi-Fi, Bluetooth, Zigbee, GPS etc are sharing these frequency ranges.

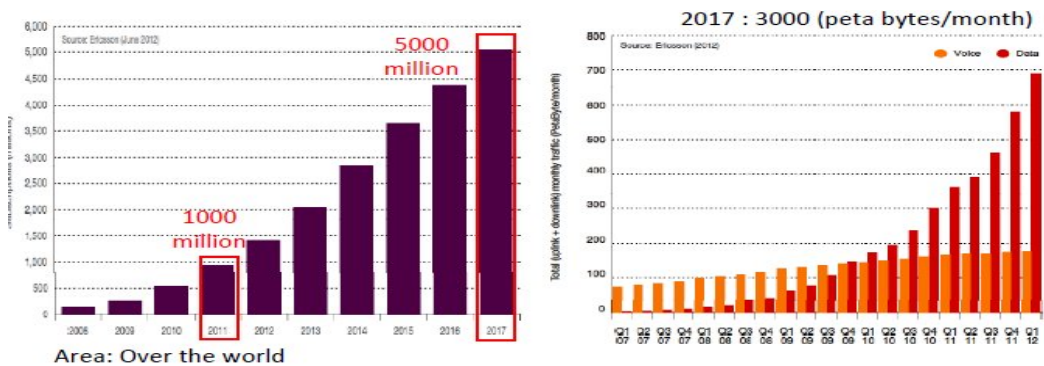

Figure 1.3: (a) Time vs. Number of mobile users, (b) Traffic vs Voice & Data [3].

Due to the rapid growth of population, the number of mobile devices increases day by day. As a result the data traffic in mobile network also increases. We can see in figure 1.3 (a) and figure 1.3 (b) two graphs which represent the current and future picture of the number of mobile devices, and the voice traffic. The graph shows that the number of mobile device

increases exponentially and the data traffic in mobile network increases exponentially as well. While the voice traffic increases linearly, where some legacy systems are spectrally or temporally inefficient which is a huge problem for wireless communication.

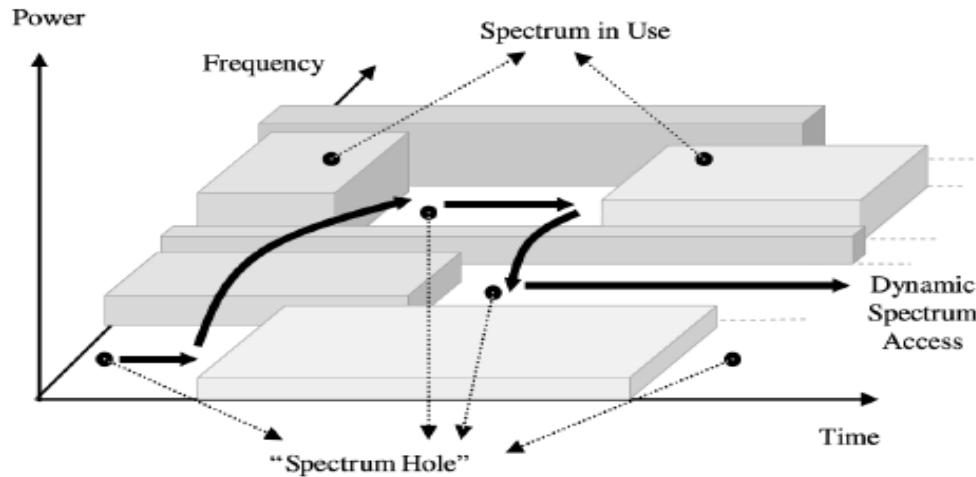

Figure 1.4: Concept of Spectrum Holes [3].

Not only that, temporal and geographical variation in spectrum utilization ranged from 15% ~ 85%. In order to utilize this spectrum (white spaces), white spaces refer to frequencies allocated to a broadcasting service but not used locally; the FCC has issued a Notice of Proposed Rule Making (NPRM-FCC 03-22) advancing Cognitive Radio (CR) technology as a candidate to implement negotiated or opportunistic sharing. The figure (1.4), depicts how CUs dynamically use spectrum holes or white spaces, which are temporarily not used in space, time and/or frequency. If a band is then used by a LU, the CU which is occupying this band goes to another spectrum hole or continues to use the band but changes its transmit power and modulation scheme so as to avoid interference with the LU. In this way, Dynamic Spectrum Access (DSA) is achieved. In the Figure 1.4, the solid arrows illustrate a possible DSA scheme.

1.1.5. Advantages of cognitive radio system

There are lots of advantages of cognitive radio system, which are given below:

- **Utilization of idle frequencies in white spaces:** National and international bodies assign different frequencies for specific uses. In most cases licensed users have the rights to broadcast over these frequencies. This frequency allocation process creates a Band-plan. This band-plan assigns white spaces for technical reasons to avoid interference. In this case, while the frequencies are unused, they have been specifically assigned for a

purpose, such as a guard band. Most commonly however, these white spaces exist naturally between using channels, since assigning nearby transmissions to immediately adjacent channels will cause destructive interference to both. In addition to white space assigned for technical reasons, there is also an unused radio spectrum which has either never been used, or is becoming free as a result of technical changes. A cognitive radio reconstructs those unused spectrums and makes them usable to the other users.

- **Adaptive communications:**

Adaptive communication is a form of communication which is tailored to someone's needs and abilities. It is designed to provide people with the ability to communicate with others

- **Robust wireless systems (network switches):** It can monitor the spectrum and choose frequencies that minimize interference to existing communication activity.
- **Dynamic spectrum access:** It has the strong ability to access free spectrum and able to modify it to use for the users who have the scarcity of spectrum.

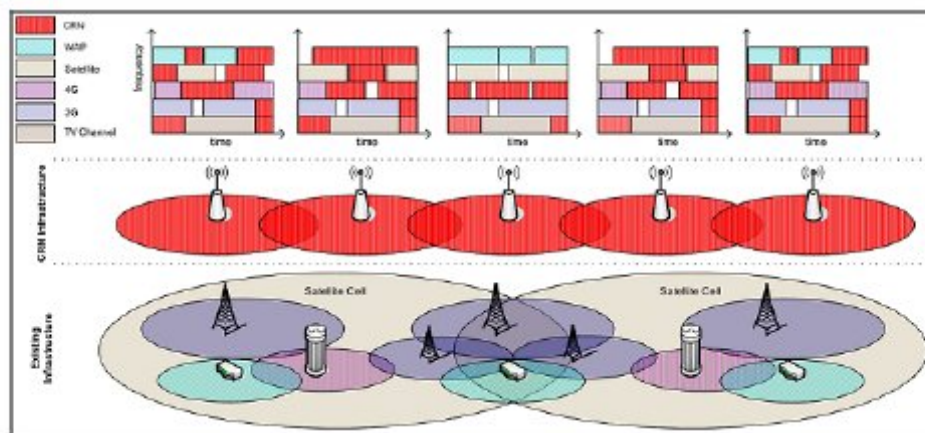

Figure 1.5: Spectrum sharing, exchanges and merchandising [3].

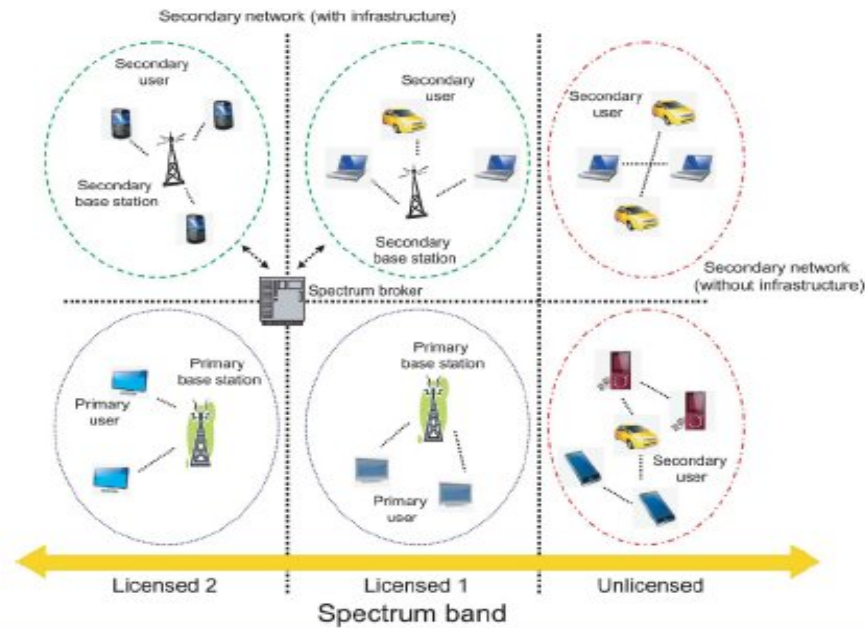

Figure 1.6: Spectrum Bands [3].

- On-demand spectrum sharing, exchanges and merchandising:** On demand when there is any scarcity or unavailability of frequency CR can share, exchange or merchandising their frequency. The above figure (1.5) and figure (1.6) shows some of those situations, where primary users are sharing spectrum with a secondary user through a spectrum broker. In figure (1.6) the primary users of licensed 1 and licensed 2 are sharing their network with secondary users and create a secondary network (with infrastructure). This network also exchanges the spectrum and create a secondary network (without infrastructure) which is used by secondary unlicensed users.

1.2. Features of Cognitive radio

The followings are the features of cognitive radio:

- Frequency Agility:** Cognitive radio has this ability to change its operating frequency to optimize the usage under certain conditions.
- Dynamic Frequency Selection (DFS):** Cognitive radio has this ability to sense signals from other nearby transmitters in an effort to choose an optimum operating environment.
- Location Awareness:** CR provides the ability for a device to determine its location and the location of other transmitters. At first, it determines whether it is permissible

to transmit at all, then to select the appropriate operating parameters such as the power and frequency allowed at its location.

- **Negotiated Use:** A cognitive radio can incorporate a mechanism that enables the sharing of spectrum under the terms of a prearranged agreement between a licensee and a third party.
- **Adaptive Modulation:** CR features with the ability to modify transmission characteristics and waveforms to exploit opportunities to use spectrum.
- **Transmit Power Control (TPC):** CR allows full power limits when it needs to transmit. But it can construct the transmitter power to a lower level to allow greater sharing of spectrum when higher power operation is not necessary.

1.2.1. Interference Management and Spectrum Sensing

In order to share the spectrum with legacy systems, cognitive radio networks need to follow some policies. This is defined by regulatory agencies. These policies are based on the central idea where there are primary systems which have the right to the spectrum and secondary systems. They allow using the spectrum as long as they do not disturb the communications of the primary systems. So, these policies deal with controlling the amount of interference that the secondary systems can incur to the primary ones. Thus, this kind of problem is considered as interference management.

1.2.2. Receiver Centric Interference Management

In the receiver centric approach, an interference limit at the receiver is calculated and used to determine the restriction on the power of the transmitters around it. This interference limit, called the interference temperature is chosen to be the worst interference level. It can be accepted without disturbing the receiver operation beyond its operating point. This approach requires knowledge of the interference limits of all receivers in a primary system. Such knowledge depends on many variables, including individual locations, fading situations, modulations, coding schemes and services. Receiver centric interference management techniques will not be addressed in this chapter as they have been recently ruled out by the IEEE SCC41 cognitive radio network standard.

1.2.3. Transmitter Centric Interference Management

In the transmitter centric approach, the focus is shifted to the source of interference. The transmitter does not know the interference temperature, but by means of sensing, it tries to detect free bandwidth. The sensing procedure allows the transmitter to classify the channel status to decide whether it can transmit and if yes, with how much power. In an actual system, since the transmitter does not know the location of the receivers or their channel conditions, it is not able to gather how much interference these receivers can tolerate. Thus, spectrum sensing solves the problem for the worst case scenario. Assuming strong interference channel, the secondary system transmits only when it senses an empty medium.

[4]

Chapter 2

Literature Survey

During the literature survey lots of different research papers, books and journals were covered related to this thesis. Some of the topics that we have gone through during this period are in the following subsections.

2.1 Cognitive Cycle:

A basic cognitive cycle begins with radio scene analysis and identifying the spectrum holes, which is shown in figure (2.1). In addition, it also performs channel estimation for the channel capacity, channel state, transmitted power, transmitted frequency, issued signal to transmit power control and manage the spectrum management. Finally, the cycle establishes connection with a proper initial handshake with the receiver.

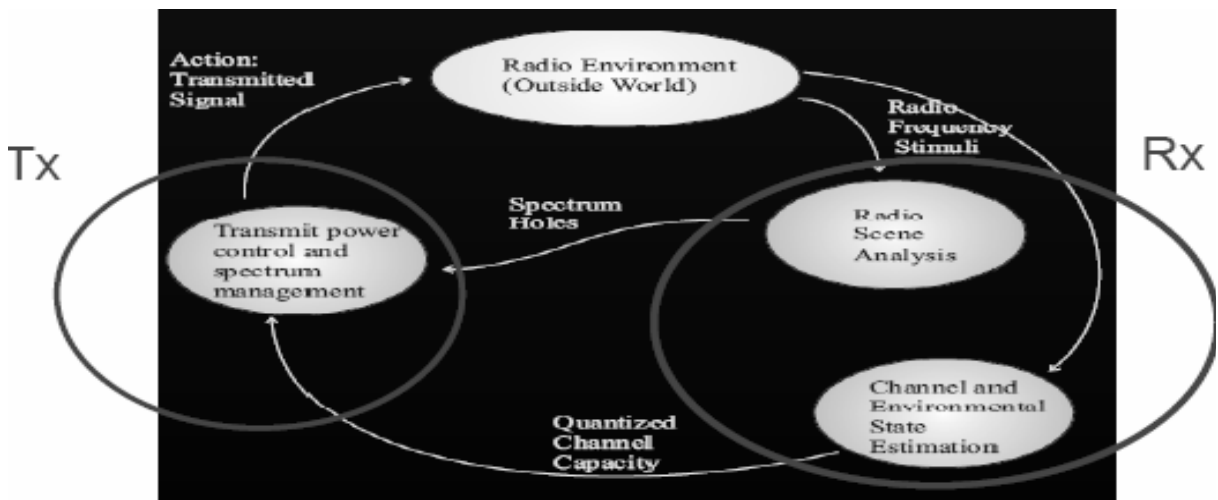

Figure 2.1: Cognitive Cycle [5].

Raut and Kulat conducted a study to improve spectrum utilization in the paper “Cognitive radio technology” [5]. In this paper, they have verified the efficiency of the algorithm. It configures the convolution encoder to produce a lower BER for increased bandwidth available. For this reason they have tested FPGA implementation of the convolution encoder by using a Matlab HDL coder [5].

At the present time, Cognitive Radio is becoming a promising technology for improving spectrum application. The research work which is discussed here is mailing the tracks for rate adoptive coder compliant with minimum BER for emergency services over cognitive radio. The results verify the efficiency of the algorithm. It configures the convolution encoder to produce a lower BER for increased available bandwidth. This can be eagerly implemented in the SDR library functions. This has been tested by FPGA implementation of the convolution encoder by using a Mat lab HDL coder. The coder has presented the output of the FPGA implemented VHDL code [5].

In this article, the concept of cognitive radio and the problem as a coder adaption for available bandwidth is defied. So, the proposed algorithm at the Smart Codec is the solution for the problem. It justifies its applicability by presenting the simulation and hardware implementation results [5].

2.1.1 Types of Cognitive Radio

There are various kinds of cognitive radio. In this article “Spectrum Sensing Smart Codec Design for Cognitive Radio” [5], the authors have discussed about some of them. Cognitive Radio is classified depending on the set of parameters. These parameters are chosen from transmission and reception changes and for historical reasons. One of them is known as Full Cognitive Radio ("Mitola radio") [5] in which every possible parameter is observable by a wireless node. Another one is Spectrum Sensing Cognitive Radio. In this type of cognitive radio, only the radio frequency spectrum is considered.

On the component of the spectrum availability, Cognitive Radio can be classified into two classes. First one is Licensed Band Cognitive Radio, where cognitive radio is capable of using bands assigned to licensed users, apart from unlicensed bands. Another one is Unlicensed Band Cognitive Radio, which can only utilize only unlicensed parts of radio frequency spectrum.

2.1.2 Main Functions of Cognitive Radio

The followings are the major functions of Cognitive Radio:

(a) **Spectrum Sensing-** An essential capability of the CR is spectrum sensing, i.e., The capability of timely sensing spectrum holes. This is also the basis and precondition for CR application. In order not to interfere with the LU, when a CU uses a spectrum hole to communicate, it has to quickly detect the presence of the LU and timely exit from a related band or continues to use the band for communication if the interference threshold is not exceeded. As a result, CUs should be equipped with highly reliable spectrum sensing function and be able to detect spectrums in a continuous and real-time way.

(b) **Spectrum Management-** Spectrum analysis and spectrum decision are the most important tasks to be carried out during Spectrum Management.

(c) **Spectrum Mobility-** This should ensure seamless operation and most exchange operating frequencies accordingly.

(d) **Spectrum Sharing-** Spectrum scheduling method takes care of sharing the available spectrum.

But present work lies in for the spectrum sensing cognitive radios. Once a bandwidth is available and wide enough, we have two options:

- Transmit bulk data at higher data rate e.g. real time applications like mobile services.
- Transmit small packets of data with high accuracy, required in Emergency Services (time bound emergency information should take care of data reduction by minimizing the possible size so as to utilize low data rates where BER is low).

But present work focuses on the second option for improving the BER performance of the system.

2.1.3 Modelling and Simulation of Spectrum Sensing by Smart Codec for Cognitive Radio

For modelling, first thing is to prepare a simple digital communication system model and then test the encoder and decoder design using a MATLAB Simulink. Then, the next step is to test the functionality of the codec in the DCOM System. After that, a gate level model of the encoder was prepared knowing the fact that a Matlab Simulink to HDL Converter supports

only the behavioural level blocks. These steps were carried out to test the hardware implementation possibility of the codec [5]. The gate level design is given below in figure (2.2)

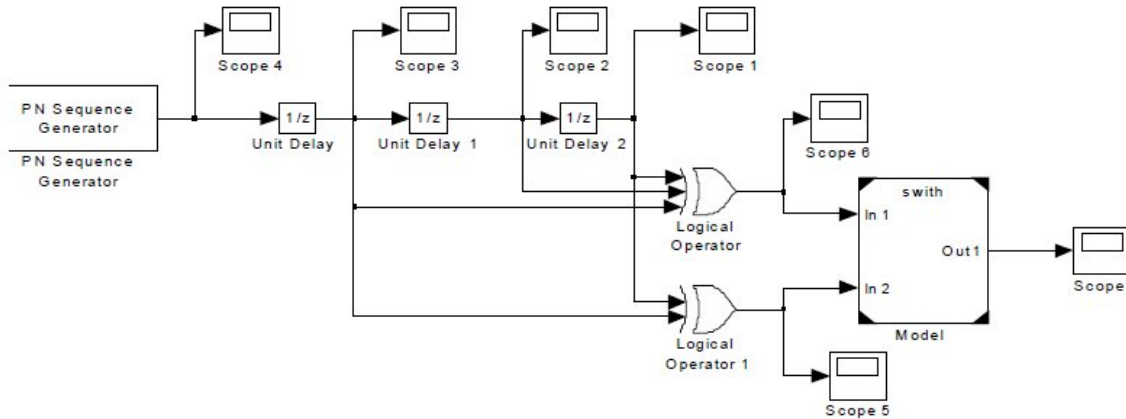

Figure 2.2: Gate level Design of the convolution Encoder for Simulink to HDL conversion [5].

In the above model, data bits are randomly generated to represent random speech signals. The bit generation frequency also changes, considering the variations in human speech. Here, the authors are not concerned with the amplitude variations. The model has been worked out for varying frequencies of input data and performs equally well over the entire specified range of frequencies of input data. Thus, the model takes shape with the following three parameters as user has defined.

1. Input data start frequency,
2. Input data end frequency
3. Observation time.

The result is presented in the form of bits on the computer screen and to plot the graphs the working frequencies were scaled down. The model works equally well at high frequencies and was tested for a few sample data at high frequencies. The problem, which the authors faced, was the simulation time taken increases to hours, due to the computational time required in finding the checksum bits that are derived from input bit streams [5].

The first model was a simple non adaptive digital communication system where the codec does not adapt to the available bandwidth. It was found that as the bandwidth increases the BER increases which is clear from the graph in figure (2.3) below.

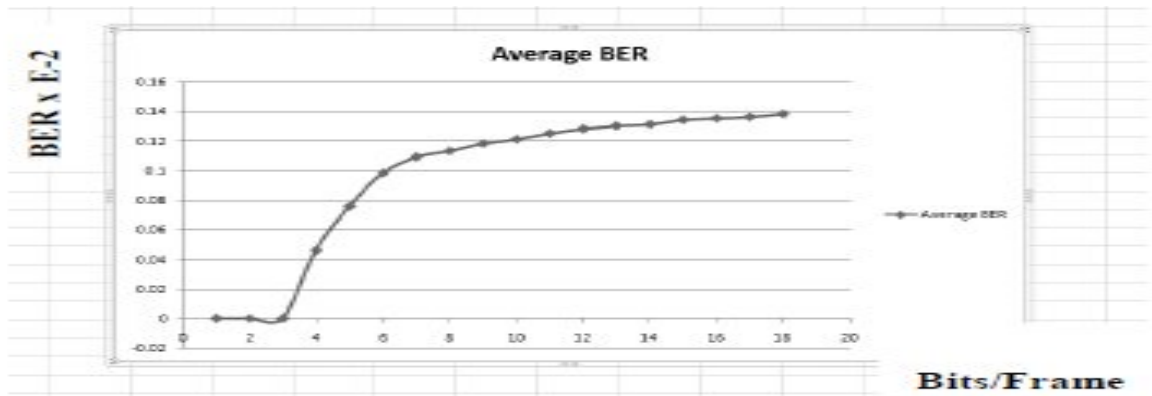

Figure 2.3: Bandwidth vs BER [5].

The second model was prepared by an algorithm by adapting to the increasing bandwidth and utilizing this bandwidth to make the data more secure to reduce the BER. The graph below, figure (2.4) shows that the adaptive codec reduces the BER with increase in frame size that which results from increase in bandwidth.

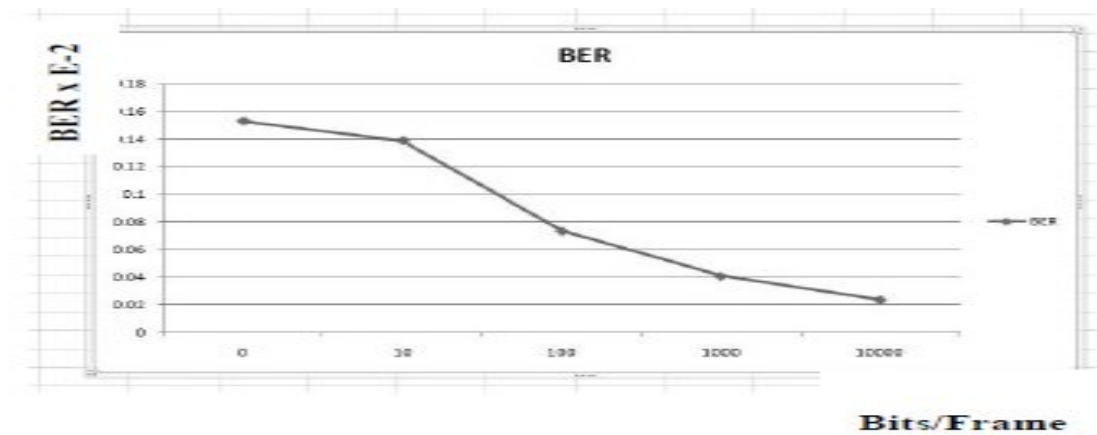

Figure 2.4: Bandwidth vs BER [5].

Cognitive users monitor the spectrum and are allowed to use it as long as it does not interfere with primary users to whom it has been licensed. We have proposed the design of a Smart Codec using convolution codes wherein the codec senses the spectrum availability and accordingly modifies the algorithm for coding –decoding [5].

2.2 Sensing Setup

Sensing setup consists of a computer/laptop, spectrum analyzer and one Omni directional antenna. National Instruments (NI) LabVIEW-8.5 is installed on the computer to control the spectrum analyzer and acquire the sensing data. The computer and spectrum analyzer are connected using GPIB-USB2 cable. A linearly polarized Omni directional antenna with 50 ohm unbalanced feed impedance is used for all sensing scenarios.

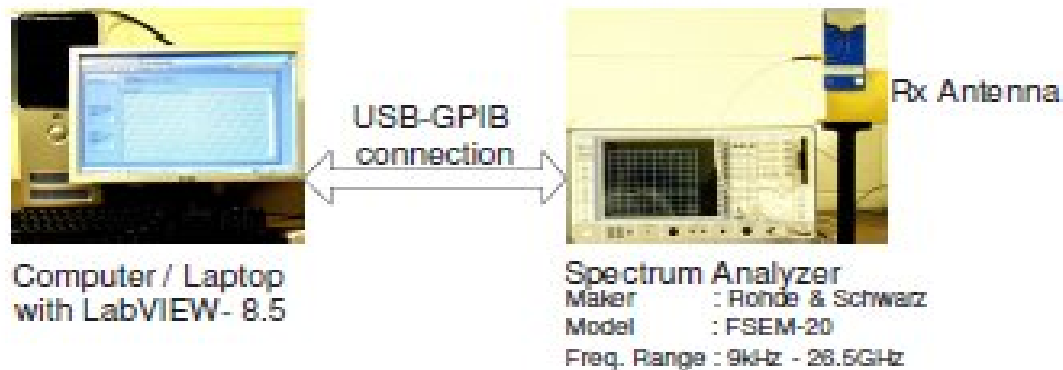

Figure 2.5: Setup diagram [6].

2.2.1 The procedure for sensing the spectrum

The followings are the steps for the spectrum sensing procedure:

- Connect the spectrum analyzer, computer/laptop and receiving antenna.
- Power on the spectrum analyzer and manually set the parameters such as start/stop frequency, resolution bandwidth, video bandwidth, attenuation, sweep time etc.
- Open the Lab VIEW block diagram on the remote computer with NI's LabVIEW-8.5 installed on it. For Select the instrument GPIB port address from the menu list that appear on 'Input Instrument Port' option box.
- Select the sweep mode as Single Sweep display ON in 'Set Sweep Mode' option box .One sweep is characterized by three parameters is sweep time, resolution bandwidth and video bandwidth, where sweep time is the time taken by a spectral trace to complete its path from given start frequency to stop frequency during one trigger.
- Select the appropriate trace mode in "Set Trace Type" option. A trace consists of 500 pixels on the horizontal frequency axis that means the number of points for each

measurement is 500. Selection of trace mode depends on our goal i.e. what type of data we need from the spectrum analyzer. s

- Generally for a spectrum analyzer commonly mentioned trace modes are: Clear/Write, Average, Max Hold, and Min Hold. Then a 'FOR LOOP' is introduced in the next step and the functionality attached with this 'FOR LOOP'.

Figure (2.6) shows the block diagram of developed VI to control spectrum analyzer. The Lab VIEW based instrument driver library for spectrum analyzer was downloaded from the Rohde and Schwarz website.

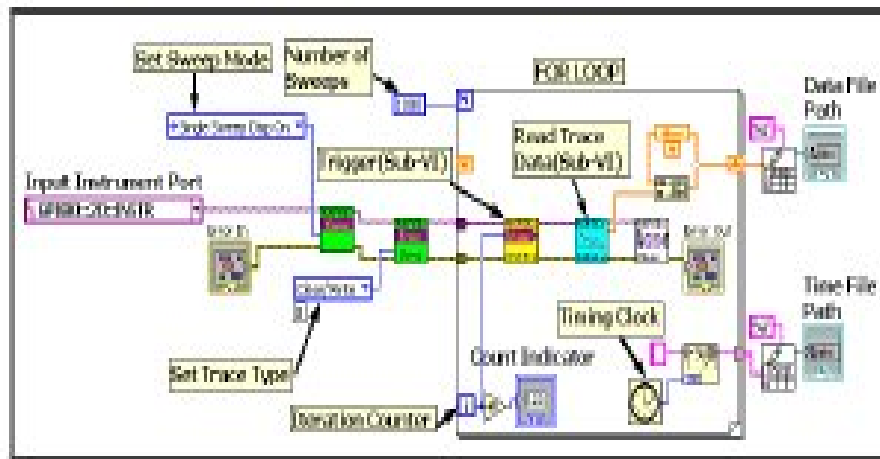

Figure 2.6: Sensing setup [6].

These drivers are used as sub VIs in the block diagram. All sub VIs are wired together in an order to read sensing data of the sensed spectrum over a long time period. Meanwhile, the sensing time for each measurement is recorded in a different file.

2.2.2 Sensing Capability

The main advantage of our equipment-based spectrum sensing is that the semi-continuous measurements can be executed and the corresponding sensed data can be recorded automatically for the online or offline signal processing.

2.3 Cognitive Radio Front-end

Spectrum sensing is best addressed as a cross-layer design problem. Cognitive radio sensitivity can be improved by enhancing radio RF front-end sensitivity, exploiting digital signal processing gain for specific primary user signal and measurements [7].

There are two frequency bands where the cognitive radios might operate in a near future: 400-800 MHz (UHF TV bands) and 3-10 GHz. The FCC has noted that in the lower UHF bands almost every geographical area has several unused 6 MHz wide TV channels. This frequency band is particularly appealing due to good propagation properties for long-range communications. The static TV channel allocations and the timing requirements for spectrum sensing are very relaxed. The FCC approval of UWB underlay networks in 3-10 GHz indicates that this frequency range might be opened for opportunistic use. Regardless of the operating frequency range, a wideband front-end for a cognitive radio could have architecture as depicted in figure (2.7). The wideband RF figure (2.7) signal presented at the antenna of a cognitive radio includes signals from close and widely separated transmitters and from transmitters operating at widely different power levels and channel bandwidths. As a result, detection of weak signals must be frequently performed in the presence of very strong signals. Thus, there will be extremely stringent requirements placed on the linearity of the RF analog circuits as well as their ability to operate over wide bandwidths. In order to keep the requirements on the final analog to digital (A/D) converter at a reasonable level in a mostly digital architecture, front-end design needs a tunable notch analog processing block that would provide a dynamic range control [7].

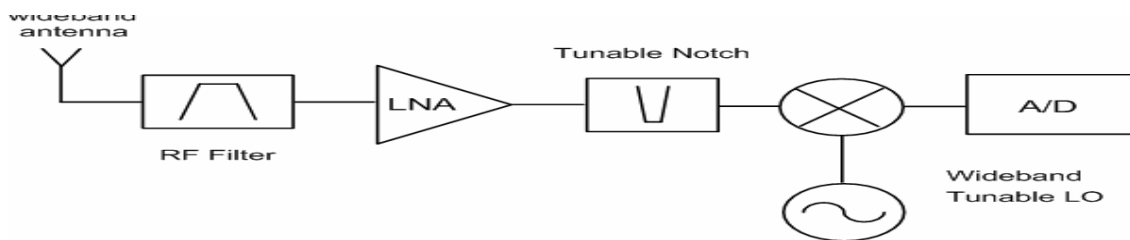

Figure 2.7: Wideband RF/analog front-end architecture for cognitive radio [7].

2.3.1 Signal processing techniques for spectrum sensing

Here, we discuss about of four techniques that are used in traditional systems.

- **Matched Filter:** The optimal way for detecting a signal is matched filter. It maximizes received signal-to-noise ratio (SNR). However, a matched filter effectively requires demodulation of a primary user signal.
- **Energy Detector:** To simplify matched filtering approach, one has to perform non-coherent detection through energy detection. This sub-optimal technique has been extensively used in radiometry. An energy detector can be implemented similarly to a spectrum analyzer by averaging frequency holder of a Fast Fourier Transform (FFT). Samples are required to meet a probability of detection constraint due to non-coherent processing.
- **Cyclostationary Feature Detection:** This can be used for detection of a random signal with a particular modulation type in a background of noise and other modulated signals. Common analysis of stationary random signals is based on auto correlation function and power spectral density. On the other hand, cyclostationary signals exhibit correlation between widely separated spectral components due to spectral redundancy caused by the periodicity spectral correlation function is also termed as cyclic spectrum.
- **Cooperative Spectrum Sensing:** The performances of these techniques are limited by received signal strength which may be severely degraded due to multipath fading and shadowing. In such a scenario cooperative sensing may alleviate the problem of detecting the primary user by reducing the probability of interference to a primary user. In cooperative sensing we rely on the variability of signal strength at various locations. It is expected that a large network of cognitive radios with sensing information exchanged between neighbors would have a better chance of detecting the primary user compared to individual sensing.

2.3.2 Pros and Cons of the signal processing techniques for spectrum sensing

The pros and cons of the four techniques of signal processing are described below by a table, which helps us to find out which signal processing technique is better for spectrum sensing.

Table 1.1: Overview of available techniques for spectrum sensing [7].

Spectrum Sensing Technique	Advantage	Disadvantage
Matched Filter	<ol style="list-style-type: none"> 1. Best in Gaussian knowledge 2. Need shorter sensing duration. 3. Less power consumption. 	<ol style="list-style-type: none"> 1. Requires a prior info on PU transmissions, and extra hardware on nodes for synchronization with PU.
Energy Detection	<ol style="list-style-type: none"> 1. Requires the least amount of computational power of nodes. 	<ol style="list-style-type: none"> 1. Requires longer sensing duration. 2. Higher power consumption. 3. Accuracy highly dependent on noise level variations.
Cyclo-stationary Feature Detection	<ol style="list-style-type: none"> 1. Most flexible to variation in noise levels. 	<ol style="list-style-type: none"> 1. Requires a prior knowledge about PU transmissions. 2. Requires high computation capability on nodes.
Cooperative Sensing	<ol style="list-style-type: none"> 1. Recommended by the FCC. 2. Guarantees a predetermined interference to PU is not exceeded. 	<ol style="list-style-type: none"> 1. Requires knowledge of location PU and imposes polynomial calculations based on these locations.

Chapter 3

Methodology Adopted and Justification of the Thesis

3.1 Introduction

This chapter mainly focuses on the justification of this thesis based on cooperative sensing according to three rules which are AND, Majority, OR rules. Here, we have analyzed the Cooperative Spectrum Sensing under the AWGN channel and the relation of cognitive radio with Software defined radio and Adaptive Radio. From this chapter, we can understand the methodology adopted for the simulation and also find out the better rule for the simulation.

3.2 Relation between Software defined radio and Cognitive Radio

Software defined radio usually concerns of using software processing within the radio system or device to implement operation.

- ✓ Cognitive radio (CR) requires a flexible radio device. Software defined radios (SDRs) are ideal platform for Cognitive radio.
- ✓ Software defined radio (SDR) might not be necessary for cognitive radio (CR), but highly desirable.
- ✓ Software defined radio might possibly do the job for most interpretations of cognitive radio.
- ✓ Multiband and Multimode radio devices can do the job for some cognitive radio interpretations.

3.3 Relation between Adaptive Radio and Cognitive Radio

The adaptive radio system has a feature of demonstrating an awareness of its environment and an ability to automatically react. Cognitive radio and adaptive wireless in essence mean the same thing. Cognitive radio can include additional features beyond adaptation.

3.5 Local Spectrum sensing

To achieve accuracy and improve reliability, cooperative spectrum sensing is usually used. But the cost of cooperation is overhead among CR users. This overhead can be reduced by improving local spectrum sensing accuracy as we know that an accurate spectrum sensing technique can reduce the probability of false alarms and miss detection.

3.6 Probability of false alarm and probability of miss detection

There are two types of errors in spectrum sensing such as false alarm and miss-detection. The probability that the signal when present will be detected is called probability of detection. The probability of a noise fluctuation which is mistaken for a signal is called probability of false alarm. Underutilization of the spectrum of the primary users and secondary users can be determined by these false alarm and miss-detection.

3.7 Energy Efficiency

We know that as the number of cooperating users grows, the energy consumption of the cognitive radio network increases but its performance generally saturates. For this reason to improve the energy efficiency in cognitive radio networks, some techniques have been developed. One simple technique to save energy is on-off sensing or sleeping, where every cognitive radio will randomly turn off its sensing device with a probability of the sleeping rate. Another technique is censoring. In such a system, a cognitive radio will only send a sensing result if it is deemed informative and it will eliminate those sensing results that are uninformative [8].

3.8 Additive White Gaussian Noise (AWGN)

Additive white Gaussian noise (AWGN) is a channel model in which the only impairment in communication is a linear addition of wideband or white noise with a constant spectral density and Gaussian distribution of amplitude. This model does not account for fading, frequency selectivity, interference, nonlinearity [9]. In the AWGN environment, the sensing user selection scheme is equivalent to selecting the optimal number of cooperative secondary users (SU) due to all the SUs having the same instantaneous detection for signal-to-noise ratio (SNR) [9].

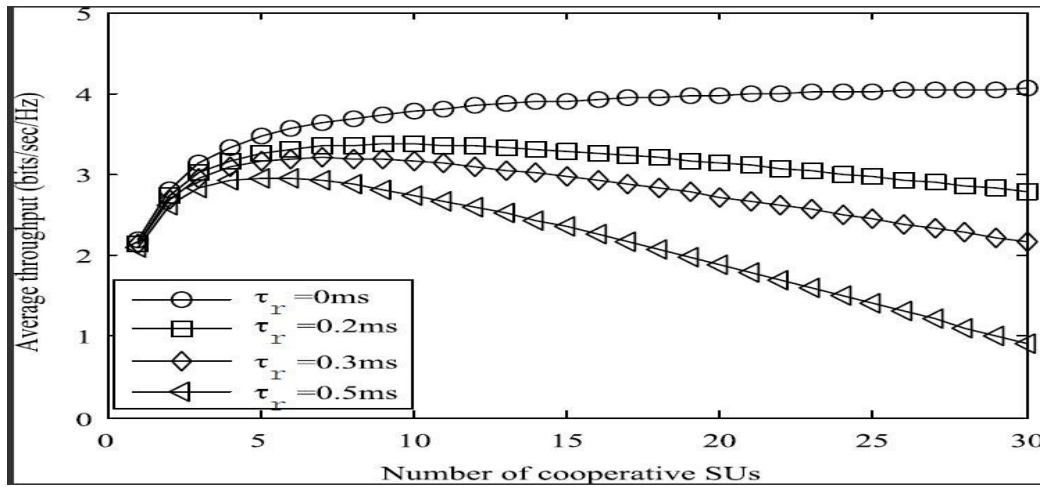

Figure 3.1: The average throughput vs the number of cooperative users in the AWGN environment [9].

In the above figure (3.1), the average throughput along the y axis and the number of cooperative SUs along the x axis is shown under different reporting delay. It can be seen that the maximum average throughput might not be achieved when all the SUs within the CRN cooperate to sense the same PU channel.

The relative power of noise in an AWGN channel is typically described by quantities such as

- ✓ Signal-to-noise ratio (SNR) per sample: This is the actual input parameter to the AWGN function.
- ✓ Ratio of bit energy to noise power spectral density (E_b/N_0): This quantity is used by BER Tool and performance evaluation functions in this toolbox.
- ✓ Ratio of symbol energy to noise power spectral density (E_s/N_0).

3.9 Methodology adopted of Cooperative Spectrum Sensing under AWGN

Cooperative Spectrum Sensing (CSS) can improve the spectrum sensing performance by introducing spatial diversity in cognitive radio networks (CRNs).

3.9.1 Soft and hard combining

In cooperative detection when each sensor takes the own decision and transmits only its binary number to the fusion centre, the fusion centre combines the hard decision to one common decision. Overall, we can say that all users transmit soft decision to a fusion centre which combines the soft values to one common decision. If we think there are M sensors and

wish to detect whether there is a signal present or not then we have to discriminate between the following two hypothesis tests

$$H_0: y_m = W_m, \quad m = 0, \dots, M - 1, \dots \dots \dots (3.1)$$

$$H_1: y_m = X_m + W_m, \quad m = 0, \dots, M - 1, \dots \dots \dots (3.2)$$

Here (y_m) is the signal vector of length m which consists of a signal pulse noise. In the equation 3.2, (X_m) is the signal vector and (W_m) is the noise vector.

If the received signals at all sensors are independent. Let, $Z = (y_0^T, y_1^T, \dots, y_{M-1}^T)^T$, then the log-likelihood ratio will be,

$$A_{coop} \triangleq \log \left(\frac{P(Z|H_1)}{P(Z|H_0)} \right) \dots \dots \dots (3.3)$$

$$A_{coop} = \sum_{m=0}^{M-1} \log \left(\frac{P(y_m|H_1)}{P(y_m|H_0)} \right) \dots \dots \dots (3.4)$$

$$A_{coop} = \sum_{m=0}^{M-1} A(m) \dots \dots \dots (3.5)$$

Here, $A(m) \triangleq \log \left(\frac{P(y_m|H_1)}{P(y_m|H_0)} \right)$ is the log-likelihood ratio for the m^{th} sensor. It means that if all the sensor of receive signal is independent, then the soft combining of fusion rule is equal to sum of log-likelihood ratios so that we can say log-likelihood ratio depends on the distribution of the signal to be detected [10].

3.9.2 Justification behind selecting AND rule

There are different rules for combining cooperative sensing such as AND, OR and VOITING / Majority rules. The OR rule decides the signal present if any of the sensor reports signal detection. So for the OR rule, the cooperative test decides on H_1 , if

$$\sum_{m=0}^{M-1} A(m) = 1 \dots \dots \dots (3.6)$$

Assume that the individual statistics $A(m)$ are quantized to one bits such that $A(m) = 0, 1$ is the hard decision from the m^{th} sensor. In this case when a signal is detected then it becomes 1

otherwise it becomes 0.

The VOTING or Majority Rule decides that a signal is present if at least V of the M sensor or user has detected a signal for $1 \leq V \leq M$. Then the test decides H_1

$$\sum_{m=0}^{M-1} A(m) \geq V \dots\dots\dots(3.7)$$

Here V is considered as $M/2$.

In AND-rule, sensing results should be H_1 where H_1 is the alternate hypothesis, where the observed band is occupied by a primary user. If all sensor have detected a signal, then an AND rule decides that a signal is detected. So, here the cooperative test using the AND rule decides on H_1 , if

$$\sum_{m=0}^{M-1} A(m) = M \dots\dots\dots(3.8)$$

In our thesis paper for the spectrum sensing of cooperative, we followed the AND rule because we wanted to see the effect on the probability of detection of the signal in the case of bursty situation. If we selected the OR rule here, then we could not justify the effect of the increasing users. In OR rule, if any of the sensor reports signal detection, then it decides the signal detection. On the other hand in AND rule, if all sensors detect a signal then a signal is detected. So for the proper detection of the signal and finding out the proper effect in bursty case, we have used AND rule.



Figure 3.2: (a) Non cooperative system and (b) Cooperative system [11].

As shown in figure 3.2 (a), CR users detect primary signal and decide whether the signal is present or not by themselves. However, this technique cannot detect primary signal

properly due to fading and shadowing. Figure 3.2(b), shows the system model of cooperative signal detection where only one cognitive radio user could be able to detect the primary signal. Here the users are populated in the range of primary transmitter. So it is expected that it can improve the signal detection probability [11]. From the above figures, we can understand that the cooperative sensing is an effective and attractive approach to combat multiple fading, receiver's uncertainty and hidden primary problem.

3.9.1 Calculation of AND and OR rule

In spectrum sensing there are two types of errors which are false alarm and miss-detection. The probability of detection (P_d) and probability of false alarm (P_{fa}) are used for hard decision based on cooperative spectrum sensing under the AND rule. We know that (P_d) and (P_{fa}) depend on the threshold value, noise variance and signal variance of the primary user when the SNR value is large. We can calculate the probability of detection (P_d) and probability of false alarm (P_{fa}) by the following formula:

$$P_d = Q\left(\frac{\sqrt{N}(\beta_{ED} - (\sigma_s^2 + \sigma_n^2))}{\sigma_s^2 + \sigma_n^2}\right) \dots \dots \dots (3.9)$$

$$P_{fa} = Q\left(\frac{\sqrt{N}(\beta_{ED} - \sigma_n^2)}{\sigma_n^2}\right) \dots \dots \dots (3.10)$$

Here,

σ_s^2 = the primary user signal variance

σ_n^2 = the noise variance

β_{ED} = threshold value.

After the calculation of P_d and P_{fa} , we can calculate the probability of false alarm and probability of detection of the cognitive radio for the M user under AND rule.

$$C_d = \prod_1^q P_{d,m} \dots \dots \dots (3.11)$$

$$C_{fa} = \prod_1^q P_{fa,m} \dots \dots \dots (3.12)$$

Here, q is the number of Cognitive radio. $P_{d,m}$ and $P_{fa,m}$ is the probability of detection and probability of false alarm or the M user respectively.

Similarly, we can also calculate the probability of false alarm and the probability of detection of the cognitive radio for the M user under OR rule.

$$C_d = 1 - \prod_1^q P_{d,m} \dots \dots \dots (3.13)$$

$$C_{fa} = 1 - \prod_1^q P_{fa,m} \dots \dots \dots (3.14)$$

3.8.4 Components for calculation

In our simulation we have used the following components, which are described below:

Time bandwidth factor: Bandwidth is the amount of data that can be transmitted along a channel during a specified period of time. In our simulation we have used time bandwidth factor which is $u=1200$. But here we have changed the value to see the effect of detection.

Path loss exponent: Path loss is the reduction in power density as it propagates through space. For transmitting signal there cause path loss. So here we defined the path loss exponent for free space is, $a=2$.

Constant loss: We defined the constant loss for the signal transmission which is $C=2$.

A number of cognitive radio users: To see the effect of varying cognitive radio users, we vary the user in our simulation. Initially we have kept the number of user $Crs=10$.

Chapter 4

Thesis Framework

4.1 Introduction

This chapter represents the proper framework for implementing the centralized cooperative sensing. After that we have discussed about the workflow for our simulation. Here we have also discussed the simulation process probability of miss detection curve against the probability of false alarm after varying numbers of users.

4.2 Proposed Framework for Cooperative Sensing

The framework of cooperative sensing consists of the primary users (PUs). In this case, CR users include a fusion centre (FC), all the elements of cooperative sensing, the RF environment including licensed channels and control channels with an optional remote database.

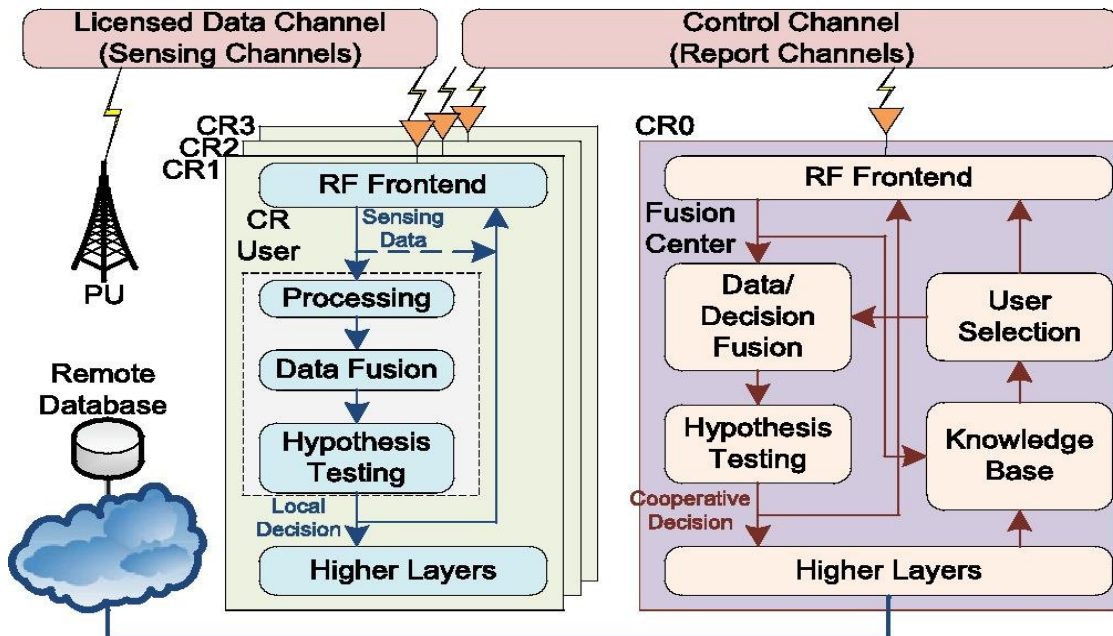

Figure 4.1: Framework of centralized cooperative sensing [12].

The above figure (4.1) illustrates the framework of centralized cooperative sensing from the perspective of the physical layer. In this proposed framework, a group of cooperating CR users performs local sensing with an RF front end and a local processing unit. The RF front end can be configured for data transmission for spectrum sensing. In addition, the RF front end includes the down-conversion of the RF signals and the sampling at Nyquist rate by an analog-to-digital converter (ADC). The raw sensing data from the RF front end can be directly sent to the FC or be locally processed for local decision. To minimize the bandwidth requirement of the control channel, certain local processing is usually required [12].

4.3 Work flow

The Cognitive Cycle begins with radio scene analysis with the scanning for spectrum holes. Once the bandwidth is available, the transmitted frequency is decided. So a Mat-lab code written for bandwidth selection was written. So now the input signal is a digital data obtained from an analogue source. After that we sense the local spectrum sensing. Then we simulate the probability of false alarm and probability of miss detection for CR user. We have been able to find out the way to reduce the miss detection. The total work flow is given through a flow chart in figure (4.2) below.

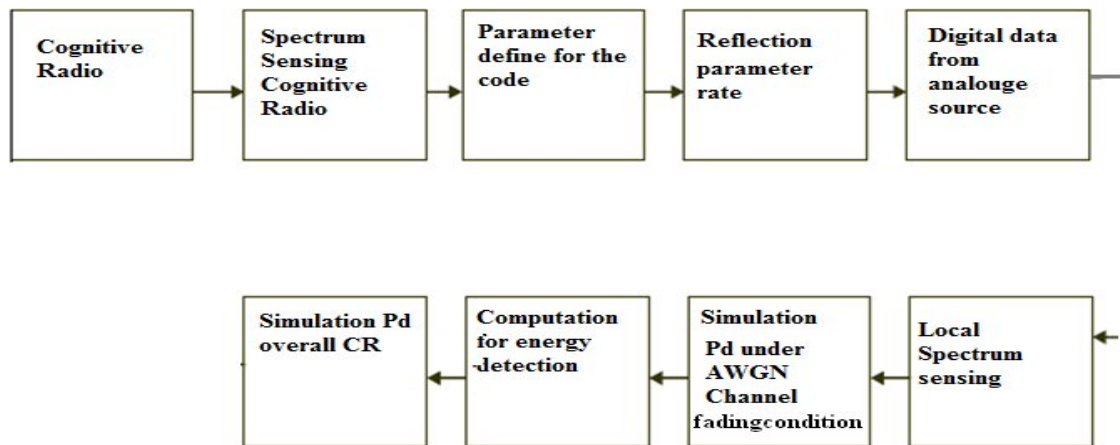

Figure 4.2: Proposed system process.

4.4 Simulation setup process

We have followed the following simulation steps to achieve our desired result. These are:

- a)** At first, we created an M-file in our simulation by MATLAB.
- b)** Then we declared the time bandwidth factor, the number of cognitive users, the path loss and the samples.
- c)** Next we calculated the probability of false alarm and the SNR. Here for calculating the linear SNR, we considered the value of SNR to be 15dB.
- d)** As we know that an accurate spectrum sensing technique can help to detect the more accurate probability of false alarms and miss detection, so we calculated the local spectrum sensing for detecting the path loss and miss detection.
- e)** Then we detected the number of users under AWGN channels and fading condition. As we know under AWGN channels and fading condition, the sensing user scheme is equivalent to selecting the optimal number of secondary user (SU) due to all the SUs having the same instantaneous detection signal-to-noise ratio (SNR).
- f)** To justify the effect of the cognitive user in the define bandwidth we increase the number of users.
- g)** After that we also change the time bandwidth factor for finding out the effect in our simulation.
- h)** Finally, we have been able to find out the effect of probability of false alarm and probability of detection.

Chapter 5

Result Analysis

5.1 Introduction

In this chapter we describe our simulation results in details. Here we have analyzed the graph and discussed about our resort. Finally, we compared our result with other relevant research works, which we have previously discussed in chapter 2.

5.2 Result Analysis

First of all, we simulated the miss detection for the fixed bandwidth factor. In the following figure (5.1), the given SNR value is 15dB and the time bandwidth factor is 1200. Here with the increase of probability of false alarm (P_{fa}) under AND rule, initially probability of miss detection in a transmission way will increase. But after some time it becomes a steady state.

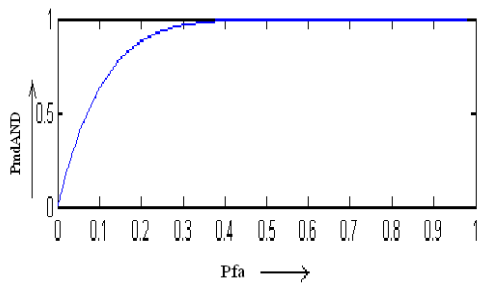

Figure 5.1 (a): Pfa vs Pmd AND for bandwidth OR for 1200.

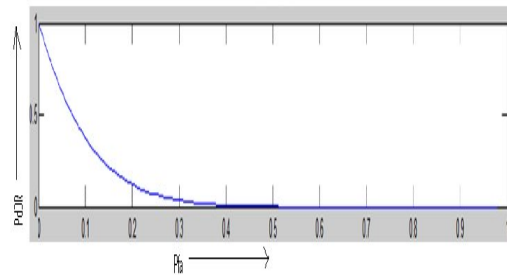

Figure 5.1 (b): Pfa v's Pd Bandwidth 1200.

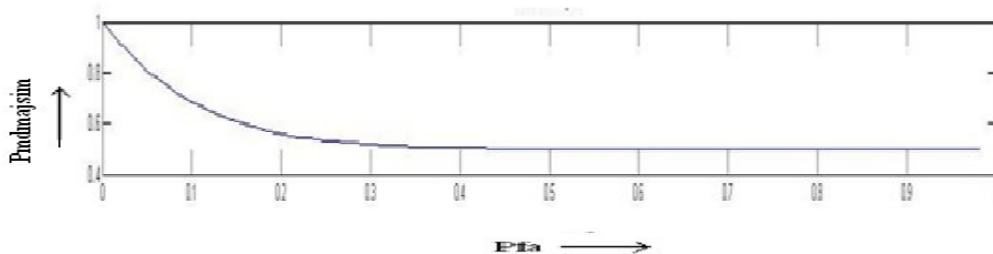

Figure 5.2: Pfa vs Pmdmaj for bandwidth 1200.

We know that when the energy consumption of the cognitive radio network increases the performance and consumption also generally saturates. We can see from the above figure 5.1 (a) that the probability of detection saturates within the consumption saturation.

Then in the following figure 5.1 (b), we see that under OR rule, probability of miss detection in a transmission way decreases with the increase of probability of false alarm (Pfa). It shows that this curve gives the opposite performance of AND rule. So here the detection probability is decreasing with the false alarm. In figure (5.2) we show the curve for majority or voting rule. It gives better performance than the OR rule but lower than AND rule.

Then in the following figure 5.2 (a) we have changed the time bandwidth factor from 1200 to 2000 for the same user and SNR value by using AND rule. We can see that for the change of time bandwidth factors there is no effect on the probability of miss detection.

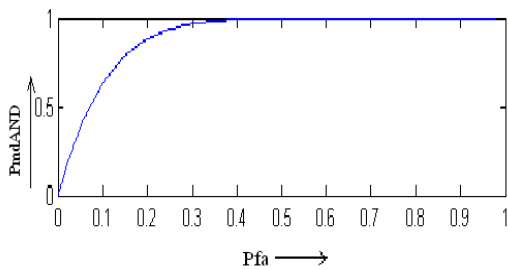

Figure 5.3 (a): Pfa vs Pmd AND for Bandwidth factor 2000.

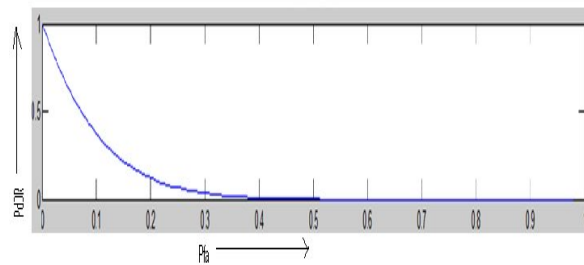

Figure 5.3 (b): Pfa v's Pd OR for Bandwidth factor 2000.

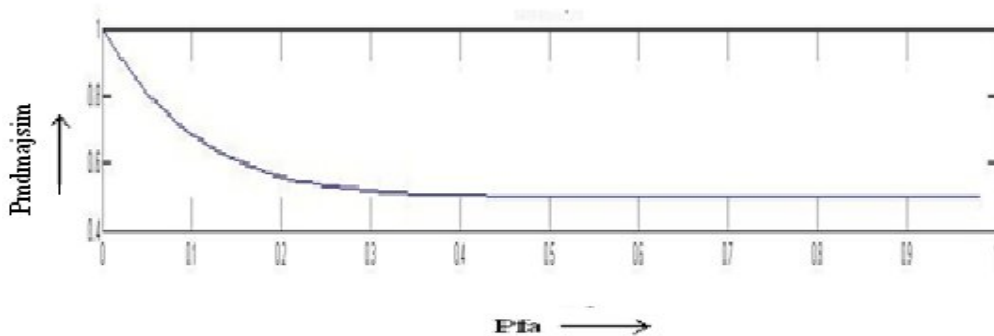

Figure 5.4: Pfa vs PmdMAJ for Bandwidth 2000.

In figure (5.3 (b)) and figure (5.4), we have also changed the time bandwidth factor from 1200 to 2000 for the probability of detection by using OR rule and Majority rule respectively.

Same as before we can see that for the change of time bandwidth factors there is no effect on the probability of detection with the change of probability of false alarm.

When the noise power is only known to be contained within a bounded interval and the decision threshold is set to guarantee an upper bound on P_{fa} then achieving a desired P_d depends on the higher SNR value than a minimum level. Because of that P_d does not depend on time bandwidth factor.

Then in the following figure 5.5 (a), we observed the plot for the probability of miss detection for minimum number of users. The value of probability of miss detection for a given value of probability of false alarm increases in a zigzag curve with the minimum number of users. Here the detection probability could not be found out significantly.

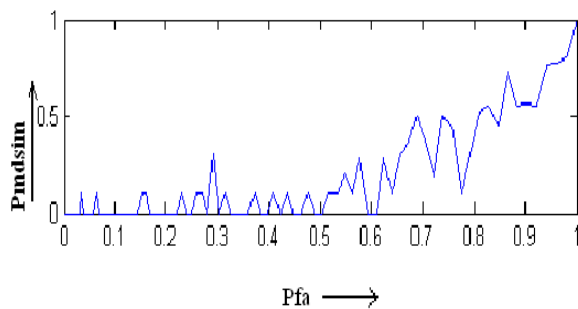

Figure 5.5(a): Pfa vs Pmd Andsim for minimum CR user .

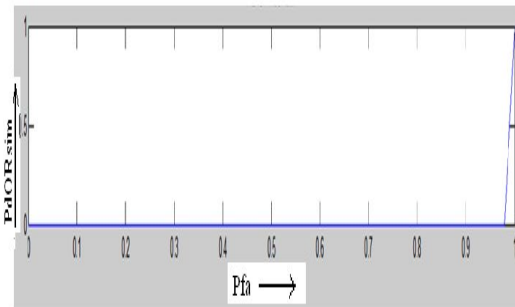

Figure 5.5(b): Pfa vs Pd OR sim for minimum CR user.

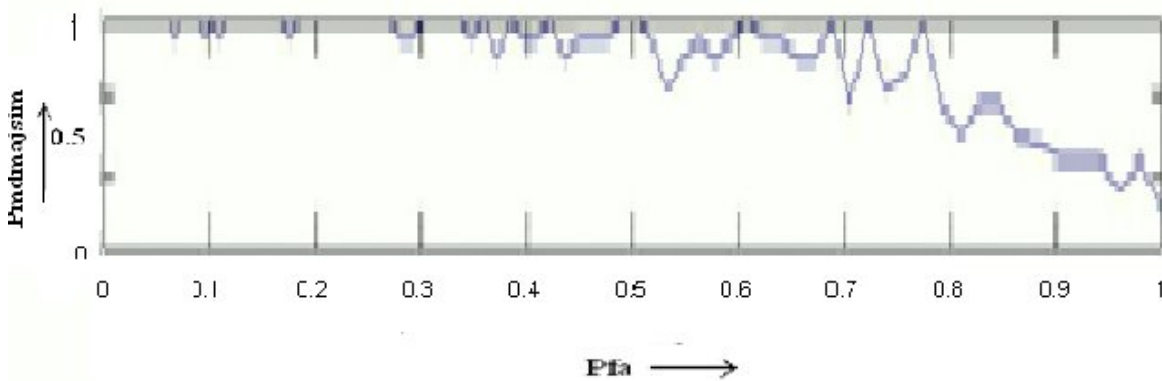

Figure 5.5 (c): Pfa vs Pdmajsim for minimum CR user .

In figure (5.5 (b)), we simulate the miss detection of user for OR rule. Here we see that the

detection probability increases with huge time. When the probability of false alarm becomes very high then it gives value for the SIM detection of the user. Otherwise it becomes zero.

In figure (5.5 (c)) we simulate the miss detection of user for Majority rule. Here we see that the detection probability also decreases with huge time. When the probability of false alarm becomes very high (at $P_{fa}=0.82$) then it gives value for the sim detection of the user. Otherwise it becomes zero.

In this view, we see that for achieving the detection probability AND rule gives better results than Majority and OR rule.

When we increased the number of cognitive users, we found that there is a change of probability of detection in the transmission way. In the following figure 5.6 (a), the probability of detection is plotted against the probability of false alarm for increasing the user numbers. Here we kept the same time bandwidth factor 1200 in order to see the effect on the probability of detection in bursty case, where it becomes saturated.

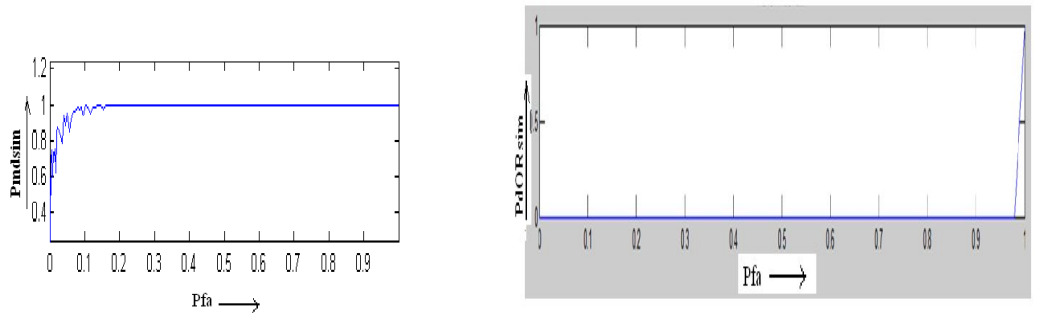

Figure 5.6 (a): Pfa vs Pmd ANDsim after changing CR user to 20.

Figure 5.6 (b): Pfa vs Pmd ORsim after changing CR user to 20.

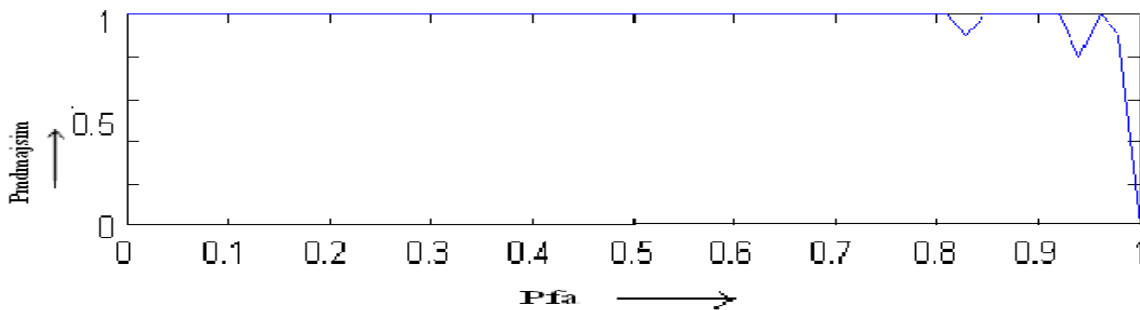

Figure 5.6 (c): Pfa vs Pmd Majsim after increasing CR user to 20.

As it can be seen from the figure 5.6 (a), the increasing number of users gives better

performance for probability of detection than the minimum user. Here a group of cooperating CR users performs local sensing with an RF front end and a local processing unit. By increasing CR users the unused spectrum decreases within the RF environment. So the increasing user number of detecting unused spectrum and sharing it, without harmful interference to other users which provides better performance for probability of detection. But in figure 5.6 (b), there are no changes in the curve after varying the number of users. Here we have kept the same time bandwidth factor to 1200 and CR user number to 20. Now in figure 5.6 (c) there is a large change in the curve after increasing the user. But still we can see that this curve cannot give sufficient result than AND rule as it decreases the probability of detection with an increase probability of false alarm increases. Here in majority rule the probability of detection decreases but it reduces zig zag magnitude with increases user number. Then in the following figure 5.7 (a), we increase the number of users to 35. We can see that there is a significant plot for the probability of detection. It means that the detection has become more significant with increasing number of users.

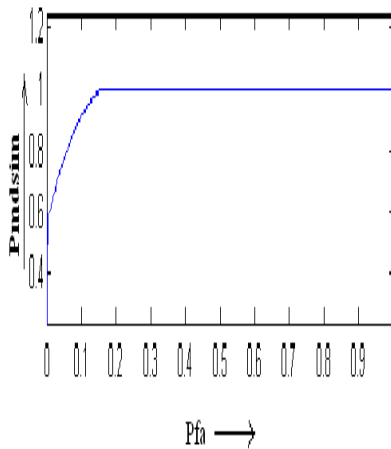

Figure 5.7 (a): Pfa vs Pmd ANDsim for increase CR user 35.

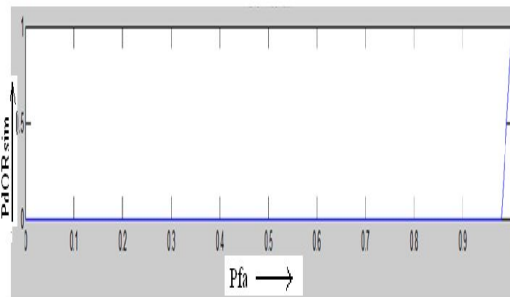

Figure 5.7 (b): Pfa vs Pmd ORsim for Increase CR user 35.

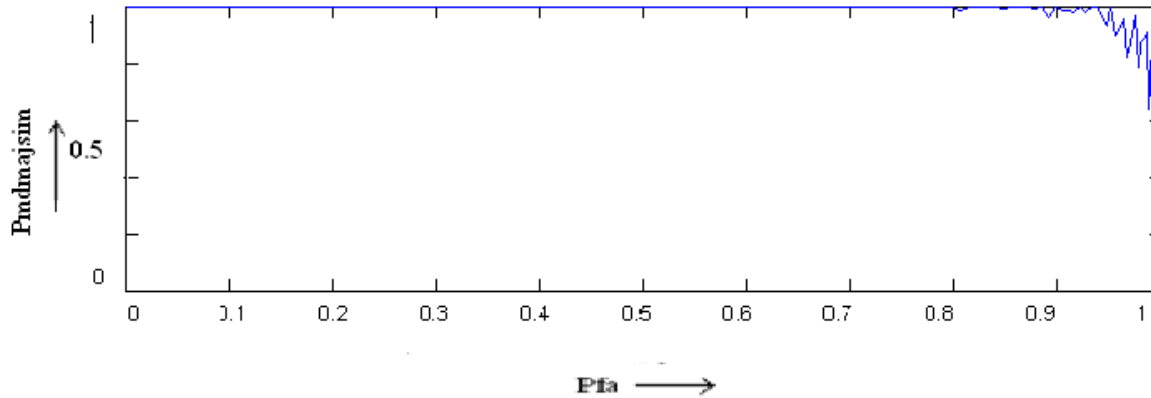

Figure 5.7 (c): Pfa vs Pmd Majoritysim for increase CR user 35.

Here, the cooperation among the cognitive users can increase the detection of probability for a given probability of false alarm. We can see in figure 5.7 (b) that with the increase of CR, the probability of miss detection of user also increases. So as the number of user increases, sensing spectrum has significantly achieved the optimal value for detection probability.

In contrast to figure 5.7 (b), increasing the user number does not affect the probability detection. Because in OR rule if any one of the user detect the signal then the probability of detection will be 1. So in this rule, misuse of the user usually occurs.

In 5.7 (c) that with the increase of CR, the probability of miss detection of user also decreases. It is better than OR that it can sense all the user. As so as it increases its user number it's curve gives a smooth decreasing curve. That is why AND rule is more effective than OR and Majority rule to find out the detection probability of the user.

We also see the effect of cognitive radio spectrum under the multipath fading channel for three rules. In fading channel the original signal and noise signal convolute with each other and generate a fading signal. In figure 5.8 (a) we see the fading signal for AND rule. From this figure we can see that the curve just fades or the amplitude becomes less than the curve of the normal AWGN channel.

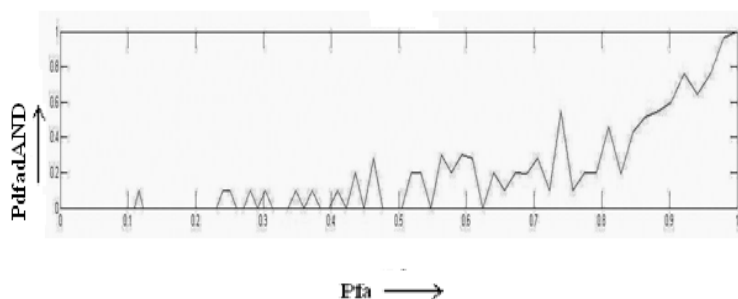

Figure 5.8(a): Pfa vs Pmd fadAND for fading channel.

In figure 5.8 (b) we see the fading signal for OR rule. In this figure we do not find the significant change of curvature due to low settling time effect. But there also some change in curve due to fading channel.

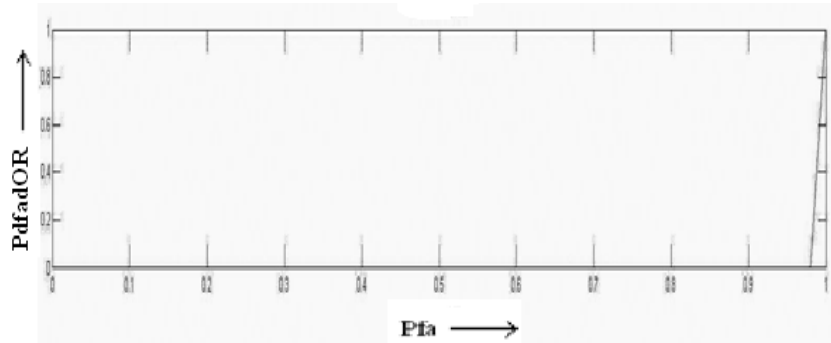

Figure 5.8 (b): Pfa vs PdfadOR for fading channel.

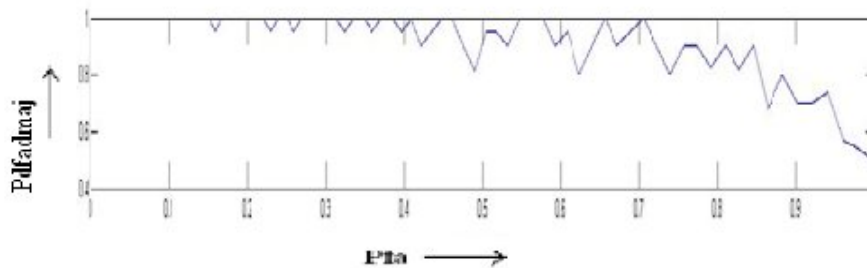

Figure 5.8 (c): Pfa vs Pdfadmajority for fading channel.

In figure 5.8 (c) the majority curves also give fade amplitude than the AWGN channel. In contrast among three curves we see that here also AND rule gives more significant curve. So we can say that in fading condition AND rule gives better detection probability than other rules.

5.3 Analysis of results for Fading Channel

In this paper we wanted to find out the significant impact for probability of detection by varying number of users. So we have selected AND rule, OR rule and majority rule for the cooperative sensing. We can neglect majority rule because it does not give as a significant result as AND rule. AND rule gives a better result for the detection probability than OR rule. We know that in AND rule if all sensors or user bases detect a signal, then a signal is detected. So, here the entire users have to use the spectrum since an accurate spectrum sensing technique can reduce the probability of false alarm and miss detection improving the energy efficiency. These simulations are done under AWGN environment. In the AWGN environment, the sensing user selection scheme is equivalent to selecting the optimal number of cooperative secondary users (SU). In the simulation part, we first observed that there were

some effects of bandwidth factor in miss detection probability for AND, OR and majority rule cases. So we have changed the bandwidth parameter keeping the higher SNR value. Then we observed that it does not affect much on the curve. In both the case (previous and new time value factor), the probability of miss detection remains same. The reason behind this is when the decision threshold is set to guarantee an upper bound on P_f then achieving a desired P_d depends on the higher SNR value than a minimum level. Then P_d does not depend on time bandwidth factor. The false alarm effects on the probability of miss detection. In AND rule, if the false alarm increases, the probability of miss detection also increases. On the other hand, in OR rule if the false alarm increases the probability of miss detection decreases. In Majority rule detection probability gives increases with false alarm but this curve has negative magnitude. After that we have sorted out the effect of probability of detection against the probability of false alarm varying the number of users by keeping the fixed SNR value 15 dB. In case of AND rule and Majority rule for the minimum user in a fixed area the detection probability does not affect significantly. Though it increases but it shows a zigzag curve, which means sometimes the probability of miss detection decreases. Here For AND rule we see the positive amplitude. For Majority rule we see the negative amplitude for probability of miss detection. But when we increase the user number of CR, it removes this zigzag curve and finds out the significant value which increases the probability of false alarm. So, finally we achieved a significant value for detection probability by increasing the CR users. But, in case of OR rule, the increasing or decreasing user number does not effect on detection curve. If any one of the users detects a signal, then this curve increases and becomes 1. In the fading condition the signal amplitude becomes faded under three rules. In contrast among three curves we see that here also AND rule gives more significant curve. So by seeing all the curves we can say that in fading condition AND rule gives better detection probability than other rules.

5.4 Comparison of the research work with other papers and real life implementation

We saw in our literature survey that Bansal and Mahajan have built a code in their paper [10] for spectrum sensing with the help of energy detection. But in our thesis, we have built a code for better detection of spectrum with the help of cooperative sensing. Their paper also shows that primary users can be increased and in the absence of each primary user, how another one detect spectrum hole and occupy the slot. But in our work we have

increased the user within the range of the RF environment. Here we showed how the CR can significantly detect the spectrum. This detection can help to detect Eigen values.

In this paper we have seen that the increasing number of users significantly increases the performance of the system. We also observed that the plot of the probability of miss detection against the probability of false alarm after varying number of users.

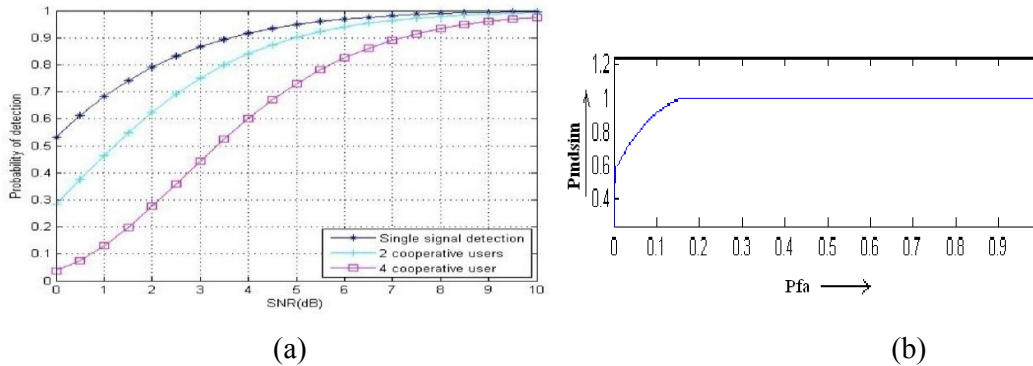

Figure 5.9: (a) Probability of detection with change of SNR [11], (b) Probability of Detection with varying user [Authors]

N. Armi, N.M. Saad and M. Arshad has shown that the probability of miss detection with varying SNR values, as it is shown in the above figure 5.8 (a). They have also focused that OR rule is a more effective role than the AND rule [11]. But in our thesis we have showed the probability of miss detection against the probability of false alarm after varying the number of users using justified AND rule. We were able to determine the miss detection curve significantly.

Hÿseyin Arslan has plotted lower BER for increased Bandwidth available [13]. But in our thesis we have been able to find for higher Pdsim and Pd.

Chapter 6

Conclusion

6.1 Conclusion

Through our thesis we found out the effect on the probability of miss detection and the probability of false alarm after varying the cognitive user by using AND rule, OR and Majority rules under the AWGN channel and Fading condition. Here we have shown that the AND rule gives better performance for probability detection than OR rule and Majority rule. In cooperative technique, AND rule is employed and it evaluates the system performance by using probability of detection (P_d) and SNR as metric. We know that cooperative sensing is an effective and attractive approach to combat multiple fading and receiver's uncertainty and hidden primary problem. For energy efficiency in cognitive radio networks, some techniques have been already developed. To minimize the bandwidth requirement of the control channel, certain local processing is usually required. So the research work on cognitive radio has been concentrated on the secondary users and none of the effect was caused by these devices for the primary users. The cost of cooperation is overhead among CR users. This overhead can be reduced by improving local spectrum sensing accuracy. As we know that an accurate spectrum sensing technique can reduce the probability of false alarm and miss detection.

6.2 Drawbacks

During the simulation, we faced various types of problems for the detection of path loss. One of the major problems we faced is when the CR user increases much then the probability of detection becomes saturated in a certain value of probability of false alarm. This is one of our limitations of our research. We would like to work at this point in near future.

6.3 Future work on cognitive radio

In our paper, it has been shown that as the cognitive user is increased, the probability of miss detection can also be significantly increased. For the better detection of probability of miss detection AND rule is much better. It may also be seen that using only a few users to help us to obtain a better detection probability compared to using all the users in the network. We would like to investigate this matter. We also designed algorithms according to which the

users must be taken into consideration for the cooperative spectrum sensing. It will be permitted that cognitive radio technology which is almost wireless networking will use to establish and to connect to any nearby accessible unused radio spectrum that facilitates the customer [13].

The combination of software defined radio and artificial intelligence will create new capabilities for the commercial and military marketplace.

References:

- [1] Joseph Mitola, "Cognitive radio an integrated agent architecture for software defined radio", IEEE Journal on Wireless Communications, vol. 23, issue no. 2, pp. 201-220, May 2000.
- [2] Kishore D. Kulat, "Cognitive radio technology", International Journal of Advanced Computer Science, vol. 1, issue no. 4, pp. 134-141, April 2009.
- [3] Sau-Hsuan Wu, "Cognitive radio systems and experiments", IEEE Wireless Communication, vol. 6, no.issue 4, pp. 633-636, August 2008.
- [4] Peter Steenkiste, Gary Minden, "Future directions in cognitive radio network research", Lincoln Laboratory Journal of communication technology, vol. 15, issue no.1, pp 97-126, 2005.
- [5] Rajeshree D. Raut, "Spectrum sensing smart codec design for cognitive radio", Journal of Computing Science & communication Technologies, vol. 46, issue no. 8, pp. 40-48, April 2010.
- [6] Amanpret Saini, Robert Qiu, "Spectrum sensing and reconstruction for cognitive radio", International Journal of Electronics and Computer Science, vol. 1, issue no. 3, pp.13-18, 2010.
- [7] D. Cabric, Shridhar Mishra, W. Brodersen "Implementation issues in spectrum sensing for cognitive radios", IEEE Journal of in Signal Processing, vol. 1, no. issue-3, pp.114-124, January 2004.
- [8] G. Larsson, Erik Axell, "Overview of spectrum sensing for cognitive radio", IEEE Journal on Selected Areas in Communications, vol. 58, no. issue- 8, pp. 322-326, 2010.
- [9] Akilah L. Hugine, W. Bostian, "Antenna selection for public safety of cognitive radio", IEEE Journal on Selected Areas in Communications, vol. 4, no. issue 6, pp. 225-240, May 2006.
- [10] Anugar Bansal, M.Mahajan, "Building cognitive radio system using matlab", International Journal of Electronics and Computer Science, vol-1, issue no.3, pp-1555-1560, November 2012.
- [11] N. Armi, N.M. Saad, M. Arshad, "Hard decision fusion based cooperative spectrum sensing in cognitive radio system", ITB Journal of Information and Communication Technology, vol. 3, issue-2, pp.109-122. 2009.
- [12] Erikh Axell, "Topics in spectrum sensing in cognitive radio", IEEE Journal on Selected Areas in Communications, vol.23, issue-5, pp.421-427, 2009.

[13] H. Arslan, "Cognitive radio, software defined radio, and adaptive wireless communication systems", IEEE Journal on Wireless Communications, vol.26, issue-6, pp. 1114-1125, May 2008.

Appendix**Matlab Simulation**

The followings are the full and complete Matlab code developed for our proposed simulation.

```

-----% title('Complementary ROC of Cooperative sensing with AND rule under AWGN');
clear all;
close all;
u=1000;%time bandwidth factor
N=2*u;%samples
a=2;%path loss exponent
C=2;%constant losses
Crs=10; %Number of cognitive radio users
PdAnd=0;
%-----Pfa-----%
Pf=0.01:0.01:1;
Pfa=Pf.^2;
%-----signal-----%
t=1:N;
s1 = cos(pi*t);
%----- SNR -----%
Snrdb=15;
Snrreal=power(10,Snrdb/10);%Linear Snr
% while Snrdb<15
for i=1:length(Pfa)
lamda=gammaimcinv(Pfa,u)*2; %theshold
%-----Local spectrum sensing-----%
for j=1:Crs %for each node
detect=0;
% d(j)=7+1.1*rand(); %random distanse
d=7:0.1:8;
PL=C*(d(j)^-a); %path loss

```

```

for sim=1:10%Monte Carlo Simulation for 100 noise realisation
%-----AWGN channel-----%
noise = randn(1,N); %Noise production with zero mean and s^2 var
noise_power = mean(noise.^2); %noise average power
amp = sqrt(noise.^2*Snreal);
s1=amp.*s1./abs(s1);
% SNRdB_Sample=10*log10(s1.^2./(noise.^2));
Rec_signal=s1+noise;%received signal
localSNR(j)=mean(abs(s1).^2)*PL/noise_power;%local snr
Pdth(j,i)=marcumq(sqrt(2*localSNR(j)),sqrt(lamda(i)),u);%Pd for j node
%Computation of Test statistic for energy detection
Sum=abs(Rec_signal).^2*PL;
Test(j,sim)=sum(Sum);
if (Test(j,sim)>lamda(i))
detect=detect+1;
end
end %END Monte Carlo
Pdsim(j)=detect/sim; %Pd of simulation for the j-th CRuser
end
PdAND(i)=prod(Pdsim);
PdOR(i)=1-prod(1-Pdsim);
end
PdAND5=(Pdth(5,:)).^5;
Pmd5=1-PdAND5;
PdANDth=(Pdth(Crs,:)).^Crs;
PmdANDth=1-PdANDth; %Probability of miss detection for AND rule
Pmdmajorith= 1-(PmdANDth/2);
PdORth=1-(Pdth(Crs,:)).^Crs;
PmdORth=1-PdORth;%Probability of miss detection for OR rule
PmdANDsim=1-PdAND;
Pmdmajosim= 1-(PmdANDsim/2);
PmdORSim=1-PdOR;
subplot(611)

```



```
plot(Pfa,PmdANDth)
title ('Pfa vs PmdANDth')
subplot(612)
plot(Pfa,Pmdmajorith)
title ('Pfa vs Pmdmajorith')
subplot(613)
plot(Pfa,PmdORth)
title ('Pfa vs PmdORth')
subplot(614)
plot(Pfa,PmdANDsim)
title ('Pfa vs PmdANDsim')
subplot(615)
plot(Pfa,Pmdmajosim)
title ('Pfa vs Pmdmajosim')
subplot(616)
plot(Pfa,PmdORsim)
title ('Pfa vs PmdORsim')
```